

Software Manual



Vector Signal Analysis

Applications Firmware R&S® FSQ-K70
1161.8038.02

VSA Extension R&S® FSMR-B73
1169.5696.02

VSA Extension R&S® FSU-B73
1169.5696.03

Printed in the Federal
Republic of Germany



Dear Customer,
throughout this manual, R&S® FSQ-K70, R&S® FSU-B73 or R&S® FSMR-B73 are abbreviated as R&S FSQ-K70; R&S® FSU-B73 or R&S® FSMR-B73.
R&S® is a registered trademark of Rohde & Schwarz GmbH & Co. KG
Trade names are trademarks of the owners

Basic Safety Instructions

Always read through and comply with the following safety instructions!









All plants and locations of the Rohde & Schwarz group of companies make every effort to keep the safety standards of our products up to date and to offer our customers the highest possible degree of safety. Our products and the auxiliary equipment they require are designed, built and tested in accordance with the safety standards that apply in each case. Compliance with these standards is continuously monitored by our quality assurance system. The product described here has been designed, built and tested in accordance with the attached EC Certificate of Conformity and has left the manufacturer's plant in a condition fully complying with safety standards. To maintain this condition and to ensure safe operation, you must observe all instructions and warnings provided in this manual. If you have any questions regarding these safety instructions, the Rohde & Schwarz group of companies will be happy to answer them.







Furthermore, it is your responsibility to use the product in an appropriate manner. This product is designed for use solely in industrial and laboratory environments or, if expressly permitted, also in the field and must not be used in any way that may cause personal injury or property damage. You are responsible if the product is used for any intention other than its designated purpose or in disregard of the manufacturer's instructions. The manufacturer shall assume no responsibility for such use of the product.

The product is used for its designated purpose if it is used in accordance with its product documentation and within its performance limits (see data sheet, documentation, the following safety instructions). Using the product requires technical skills and a basic knowledge of English. It is therefore essential that only skilled and specialized staff or thoroughly trained personnel with the required skills be allowed to use the product. If personal safety gear is required for using Rohde & Schwarz products, this will be indicated at the appropriate place in the product documentation. Keep the basic safety instructions and the product documentation in a safe place and pass them on to the subsequent users.

Observing the safety instructions will help prevent personal injury or damage of any kind caused by dangerous situations. Therefore, carefully read through and adhere to the following safety instructions before and when using the product. It is also absolutely essential to observe the additional safety instructions on personal safety, for example, that appear in relevant parts of the product documentation. In these safety instructions, the word "product" refers to all merchandise sold and distributed by the Rohde & Schwarz group of companies, including instruments, systems and all accessories.





Symbols and safety labels

							
Notice, general danger location Observe product documentation	Caution when handling heavy equipment	Danger of electric shock	Warning! Hot surface	PE terminal	Ground	Ground terminal	Be careful when handling electrostatic sensitive devices

					
ON/OFF supply voltage	Standby indication	Direct current (DC)	Alternating current (AC)	Direct/alternating current (DC/AC)	Device fully protected by double (reinforced) insulation

Tags and their meaning

The following signal words are used in the product documentation in order to warn the reader about risks and dangers.

	indicates a hazardous situation which, if not avoided, will result in death or serious injury.
	indicates a hazardous situation which, if not avoided, could result in death or serious injury.
	indicates a hazardous situation which, if not avoided, could result in minor or moderate injury.
	indicates the possibility of incorrect operation which can result in damage to the product. In the product documentation, the word ATTENTION is used synonymously.

These tags are in accordance with the standard definition for civil applications in the European Economic Area. Definitions that deviate from the standard definition may also exist in other economic areas or military applications. It is therefore essential to make sure that the tags described here are always used only in connection with the related product documentation and the related product. The use of tags in connection with unrelated products or documentation can result in misinterpretation and in personal injury or material damage.

Operating states and operating positions

The product may be operated only under the operating conditions and in the positions specified by the manufacturer, without the product's ventilation being obstructed. If the manufacturer's specifications are not observed, this can result in electric shock, fire and/or serious personal injury or death. Applicable local or national safety regulations and rules for the prevention of accidents must be observed in all work performed.

1. Unless otherwise specified, the following requirements apply to Rohde & Schwarz products: predefined operating position is always with the housing floor facing down, IP protection 2X, pollution severity 2, overvoltage category 2, use only indoors, max. operating altitude 2000 m above sea level, max. transport altitude 4500 m above sea level. A tolerance of $\pm 10\%$ shall apply to the nominal voltage and $\pm 5\%$ to the nominal frequency.
2. Do not place the product on surfaces, vehicles, cabinets or tables that for reasons of weight or stability are unsuitable for this purpose. Always follow the manufacturer's installation instructions when installing the product and fastening it to objects or structures (e.g. walls and shelves). An installation that is not carried out as described in the product documentation could result in personal injury or death.
3. Do not place the product on heat-generating devices such as radiators or fan heaters. The ambient temperature must not exceed the maximum temperature specified in the product documentation or in the data sheet. Product overheating can cause electric shock, fire and/or serious personal injury or death.

Electrical safety

If the information on electrical safety is not observed either at all to the extent necessary, electric shock, fire and/or serious personal injury or death may occur.

1. Prior to switching on the product, always ensure that the nominal voltage setting on the product matches the nominal voltage of the AC supply network. If a different voltage is to be set, the power fuse of the product may have to be changed accordingly.
2. In the case of products of safety class I with movable power cord and connector, operation is permitted only on sockets with an earthing contact and protective earth connection.
3. Intentionally breaking the protective earth connection either in the feed line or in the product itself is not permitted. Doing so can result in the danger of an electric shock from the product. If extension cords or connector strips are implemented, they must be checked on a regular basis to ensure that they are safe to use.
4. If the product does not have a power switch for disconnection from the AC supply network, the plug of the connecting cable is regarded as the disconnecting device. In such cases, always ensure that the power plug is easily reachable and accessible at all times (corresponding to the length of connecting cable, approx. 2 m). Functional or electronic switches are not suitable for providing disconnection from the AC supply network. If products without power switches are integrated into racks or systems, a disconnecting device must be provided at the system level.
5. Never use the product if the power cable is damaged. Check the power cable on a regular basis to ensure that it is in proper operating condition. By taking appropriate safety measures and carefully laying the power cable, you can ensure that the cable will not be damaged and that no one can be hurt by, for example, tripping over the cable or suffering an electric shock.
6. The product may be operated only from TN/TT supply networks fused with max. 16 A (higher fuse only after consulting with the Rohde & Schwarz group of companies).
7. Do not insert the plug into sockets that are dusty or dirty. Insert the plug firmly and all the way into the socket. Otherwise, sparks that result in fire and/or injuries may occur.
8. Do not overload any sockets, extension cords or connector strips; doing so can cause fire or electric shocks.
9. For measurements in circuits with voltages $V_{\text{rms}} > 30 \text{ V}$, suitable measures (e.g. appropriate measuring equipment, fusing, current limiting, electrical separation, insulation) should be taken to avoid any hazards.
10. Ensure that the connections with information technology equipment, e.g. PCs or other industrial computers, comply with the IEC60950-1/EN60950-1 or IEC61010-1/EN 61010-1 standards that apply in each case.
11. Unless expressly permitted, never remove the cover or any part of the housing while the product is in operation. Doing so will expose circuits and components and can lead to injuries, fire or damage to the product.
12. If a product is to be permanently installed, the connection between the PE terminal on site and the product's PE conductor must be made first before any other connection is made. The product may be installed and connected only by a licensed electrician.
13. For permanently installed equipment without built-in fuses, circuit breakers or similar protective devices, the supply circuit must be fused in such a way that anyone who has access to the product, as well as the product itself, is adequately protected from injury or damage.

14. Use suitable overvoltage protection to ensure that no overvoltage (such as that caused by a bolt of lightning) can reach the product. Otherwise, the person operating the product will be exposed to the danger of an electric shock.
15. Any object that is not designed to be placed in the openings of the housing must not be used for this purpose. Doing so can cause short circuits inside the product and/or electric shocks, fire or injuries.
16. Unless specified otherwise, products are not liquid-proof (see also section "Operating states and operating positions", item 1. Therefore, the equipment must be protected against penetration by liquids. If the necessary precautions are not taken, the user may suffer electric shock or the product itself may be damaged, which can also lead to personal injury.
17. Never use the product under conditions in which condensation has formed or can form in or on the product, e.g. if the product has been moved from a cold to a warm environment. Penetration by water increases the risk of electric shock.
18. Prior to cleaning the product, disconnect it completely from the power supply (e.g. AC supply network or battery). Use a soft, non-linting cloth to clean the product. Never use chemical cleaning agents such as alcohol, acetone or diluents for cellulose lacquers.

Operation

1. Operating the products requires special training and intense concentration. Make sure that persons who use the products are physically, mentally and emotionally fit enough to do so; otherwise, injuries or material damage may occur. It is the responsibility of the employer/operator to select suitable personnel for operating the products.
2. Before you move or transport the product, read and observe the section titled "Transport".
3. As with all industrially manufactured goods, the use of substances that induce an allergic reaction (allergens) such as nickel cannot be generally excluded. If you develop an allergic reaction (such as a skin rash, frequent sneezing, red eyes or respiratory difficulties) when using a Rohde & Schwarz product, consult a physician immediately to determine the cause and to prevent health problems or stress.
4. Before you start processing the product mechanically and/or thermally, or before you take it apart, be sure to read and pay special attention to the section titled "Waste disposal", item 1.
5. Depending on the function, certain products such as RF radio equipment can produce an elevated level of electromagnetic radiation. Considering that unborn babies require increased protection, pregnant women must be protected by appropriate measures. Persons with pacemakers may also be exposed to risks from electromagnetic radiation. The employer/operator must evaluate workplaces where there is a special risk of exposure to radiation and, if necessary, take measures to avert the potential danger.
6. Should a fire occur, the product may release hazardous substances (gases, fluids, etc.) that can cause health problems. Therefore, suitable measures must be taken, e.g. protective masks and protective clothing must be worn.
7. If a laser product (e.g. a CD/DVD drive) is integrated into a Rohde & Schwarz product, absolutely no other settings or functions may be used as described in the product documentation. The objective is to prevent personal injury (e.g. due to laser beams).

Repair and service

1. The product may be opened only by authorized, specially trained personnel. Before any work is performed on the product or before the product is opened, it must be disconnected from the AC supply network. Otherwise, personnel will be exposed to the risk of an electric shock.
2. Adjustments, replacement of parts, maintenance and repair may be performed only by electrical experts authorized by Rohde & Schwarz. Only original parts may be used for replacing parts relevant to safety (e.g. power switches, power transformers, fuses). A safety test must always be performed after parts relevant to safety have been replaced (visual inspection, PE conductor test, insulation resistance measurement, leakage current measurement, functional test). This helps ensure the continued safety of the product.

Batteries and rechargeable batteries/cells

If the information regarding batteries and rechargeable batteries/cells is not observed either at all or to the extent necessary, product users may be exposed to the risk of explosions, fire and/or serious personal injury, and, in some cases, death. Batteries and rechargeable batteries with alkaline electrolytes (e.g. lithium cells) must be handled in accordance with the EN 62133 standard.

1. Cells must not be taken apart or crushed.
2. Cells or batteries must not be exposed to heat or fire. Storage in direct sunlight must be avoided. Keep cells and batteries clean and dry. Clean soiled connectors using a dry, clean cloth.
3. Cells or batteries must not be short-circuited. Cells or batteries must not be stored in a box or in a drawer where they can short-circuit each other, or where they can be short-circuited by other conductive materials. Cells and batteries must not be removed from their original packaging until they are ready to be used.
4. Keep cells and batteries out of the hands of children. If a cell or a battery has been swallowed, seek medical aid immediately.
5. Cells and batteries must not be exposed to any mechanical shocks that are stronger than permitted.
6. If a cell develops a leak, the fluid must not be allowed to come into contact with the skin or eyes. If contact occurs, wash the affected area with plenty of water and seek medical aid.
7. Improperly replacing or charging cells or batteries that contain alkaline electrolytes (e.g. lithium cells) can cause explosions. Replace cells or batteries only with the matching Rohde & Schwarz type (see parts list) in order to ensure the safety of the product.
8. Cells and batteries must be recycled and kept separate from residual waste. Rechargeable batteries and normal batteries that contain lead, mercury or cadmium are hazardous waste. Observe the national regulations regarding waste disposal and recycling.

Transport

1. The product may be very heavy. Therefore, the product must be handled with care. In some cases, the user may require a suitable means of lifting or moving the product (e.g. with a lift-truck) to avoid back or other physical injuries.

2. Handles on the products are designed exclusively to enable personnel to transport the product. It is therefore not permissible to use handles to fasten the product to or on transport equipment such as cranes, fork lifts, wagons, etc. The user is responsible for securely fastening the products to or on the means of transport or lifting. Observe the safety regulations of the manufacturer of the means of transport or lifting. Noncompliance can result in personal injury or material damage.
3. If you use the product in a vehicle, it is the sole responsibility of the driver to drive the vehicle safely and properly. The manufacturer assumes no responsibility for accidents or collisions. Never use the product in a moving vehicle if doing so could distract the driver of the vehicle. Adequately secure the product in the vehicle to prevent injuries or other damage in the event of an accident.

Waste disposal

1. If products or their components are mechanically and/or thermally processed in a manner that goes beyond their intended use, hazardous substances (heavy-metal dust such as lead, beryllium, nickel) may be released. For this reason, the product may only be disassembled by specially trained personnel. Improper disassembly may be hazardous to your health. National waste disposal regulations must be observed.
2. If handling the product releases hazardous substances or fuels that must be disposed of in a special way, e.g. coolants or engine oils that must be replenished regularly, the safety instructions of the manufacturer of the hazardous substances or fuels and the applicable regional waste disposal regulations must be observed. Also observe the relevant safety instructions in the product documentation. The improper disposal of hazardous substances or fuels can cause health problems and lead to environmental damage.

Informaciones elementales de seguridad

Es imprescindible leer y observar las siguientes instrucciones e informaciones de seguridad!

El principio del grupo de empresas Rohde & Schwarz consiste en tener nuestros productos siempre al día con los estándares de seguridad y de ofrecer a nuestros clientes el máximo grado de seguridad. Nuestros productos y todos los equipos adicionales son siempre fabricados y examinados según las normas de seguridad vigentes. Nuestro sistema de garantía de calidad controla constantemente que sean cumplidas estas normas. El presente producto ha sido fabricado y examinado según el certificado de conformidad adjunto de la UE y ha salido de nuestra planta en estado impecable según los estándares técnicos de seguridad. Para poder preservar este estado y garantizar un funcionamiento libre de peligros, el usuario deberá atenerse a todas las indicaciones, informaciones de seguridad y notas de alerta. El grupo de empresas Rohde & Schwarz está siempre a su disposición en caso de que tengan preguntas referentes a estas informaciones de seguridad.







Además queda en la responsabilidad del usuario utilizar el producto en la forma debida. Este producto está destinado exclusivamente al uso en la industria y el laboratorio o, si ha sido expresamente autorizado, para aplicaciones de campo y de ninguna manera deberá ser utilizado de modo que alguna persona/cosa pueda sufrir daño. El uso del producto fuera de sus fines definidos o sin tener en cuenta las instrucciones del fabricante queda en la responsabilidad del usuario. El fabricante no se hace en ninguna forma responsable de consecuencias a causa del mal uso del producto.

Se parte del uso correcto del producto para los fines definidos si el producto es utilizado conforme a las indicaciones de la correspondiente documentación del producto y dentro del margen de rendimiento definido (ver hoja de datos, documentación, informaciones de seguridad que siguen). El uso del producto hace necesarios conocimientos técnicos y ciertos conocimientos del idioma inglés. Por eso se debe tener en cuenta que el producto solo pueda ser operado por personal especializado o personas instruidas en profundidad con las capacidades correspondientes. Si fuera necesaria indumentaria de seguridad para el uso de productos de Rohde & Schwarz, encontraría la información debida en la documentación del producto en el capítulo correspondiente. Guarde bien las informaciones de seguridad elementales, así como la documentación del producto, y entréguelas a usuarios posteriores.

Tener en cuenta las informaciones de seguridad sirve para evitar en lo posible lesiones o daños por peligros de toda clase. Por eso es imprescindible leer detalladamente y comprender por completo las siguientes informaciones de seguridad antes de usar el producto, y respetarlas durante el uso del producto. Deberán tenerse en cuenta todas las demás informaciones de seguridad, como p. ej. las referentes a la protección de personas, que encontrarán en el capítulo correspondiente de la documentación del producto y que también son de obligado cumplimiento. En las presentes informaciones de seguridad se recogen todos los objetos que distribuye el grupo de empresas Rohde & Schwarz bajo la denominación de "producto", entre ellos también aparatos, instalaciones así como toda clase de accesorios.

Símbolos y definiciones de seguridad

							
Aviso: punto de peligro general Observar la documentación del producto	Atención en el manejo de dispositivos de peso elevado	Peligro de choque eléctrico	Advertencia: superficie caliente	Conexión a conductor de protección	Conexión a tierra	Conexión a masa	Aviso: Cuidado en el manejo de dispositivos sensibles a la electrostática (ESD)

					
Tensión de alimentación de PUESTA EN MARCHA / PARADA	Indicación de estado de espera (Standby)	Corriente continua (DC)	Corriente alterna (AC)	Corriente continua / Corriente alterna (DC/AC)	El aparato está protegido en su totalidad por un aislamiento doble (reforzado)

Palabras de señal y su significado

En la documentación del producto se utilizan las siguientes palabras de señal con el fin de advertir contra riesgos y peligros.



PELIGRO identifica un peligro inminente con riesgo elevado que provocará muerte o lesiones graves si no se evita.



ADVERTENCIA identifica un posible peligro con riesgo medio de provocar muerte o lesiones (graves) si no se evita.



ATENCIÓN identifica un peligro con riesgo reducido de provocar lesiones leves o moderadas si no se evita.



AVISO indica la posibilidad de utilizar mal el producto y, como consecuencia, dañarlo.

En la documentación del producto se emplea de forma sinónima el término CUIDADO.

Las palabras de señal corresponden a la definición habitual para aplicaciones civiles en el área económica europea. Pueden existir definiciones diferentes a esta definición en otras áreas económicas o en aplicaciones militares. Por eso se deberá tener en cuenta que las palabras de señal aquí descritas sean utilizadas siempre solamente en combinación con la correspondiente documentación del producto y solamente en combinación con el producto correspondiente. La utilización de las palabras de señal en combinación con productos o documentaciones que no les correspondan puede llevar a interpretaciones equivocadas y tener por consecuencia daños en personas u objetos.

Estados operativos y posiciones de funcionamiento

El producto solamente debe ser utilizado según lo indicado por el fabricante respecto a los estados operativos y posiciones de funcionamiento sin que se obstruya la ventilación. Si no se siguen las indicaciones del fabricante, pueden producirse choques eléctricos, incendios y/o lesiones graves con posible consecuencia de muerte. En todos los trabajos deberán ser tenidas en cuenta las normas nacionales y locales de seguridad del trabajo y de prevención de accidentes.

1. Si no se convino de otra manera, es para los productos Rohde & Schwarz válido lo que sigue: como posición de funcionamiento se define por principio la posición con el suelo de la caja para abajo, modo de protección IP 2X, grado de suciedad 2, categoría de sobrecarga eléctrica 2, uso solamente en estancias interiores, utilización hasta 2000 m sobre el nivel del mar, transporte hasta 4500 m sobre el nivel del mar. Se aplicará una tolerancia de $\pm 10\%$ sobre el voltaje nominal y de $\pm 5\%$ sobre la frecuencia nominal.
2. No sitúe el producto encima de superficies, vehículos, estantes o mesas, que por sus características de peso o de estabilidad no sean aptos para él. Siga siempre las instrucciones de instalación del fabricante cuando instale y asegure el producto en objetos o estructuras (p. ej. paredes y estantes). Si se realiza la instalación de modo distinto al indicado en la documentación del producto, pueden causarse lesiones o incluso la muerte.
3. No ponga el producto sobre aparatos que generen calor (p. ej. radiadores o calefactores). La temperatura ambiente no debe superar la temperatura máxima especificada en la documentación del producto o en la hoja de datos. En caso de sobrecalentamiento del producto, pueden producirse choques eléctricos, incendios y/o lesiones graves con posible consecuencia de muerte.

Seguridad eléctrica

Si no se siguen (o se siguen de modo insuficiente) las indicaciones del fabricante en cuanto a seguridad eléctrica, pueden producirse choques eléctricos, incendios y/o lesiones graves con posible consecuencia de muerte.

1. Antes de la puesta en marcha del producto se deberá comprobar siempre que la tensión preseleccionada en el producto coincida con la de la red de alimentación eléctrica. Si es necesario modificar el ajuste de tensión, también se deberán cambiar en caso dado los fusibles correspondientes del producto.
2. Los productos de la clase de protección I con alimentación móvil y enchufe individual solamente podrán enchufarse a tomas de corriente con contacto de seguridad y con conductor de protección conectado.
3. Queda prohibida la interrupción intencionada del conductor de protección, tanto en la toma de corriente como en el mismo producto. La interrupción puede tener como consecuencia el riesgo de que el producto sea fuente de choques eléctricos. Si se utilizan cables alargadores o regletas de enchufe, deberá garantizarse la realización de un examen regular de los mismos en cuanto a su estado técnico de seguridad.
4. Si el producto no está equipado con un interruptor para desconectarlo de la red, se deberá considerar el enchufe del cable de conexión como interruptor. En estos casos se deberá asegurar que el enchufe siempre sea de fácil acceso (de acuerdo con la longitud del cable de conexión, aproximadamente 2 m). Los interruptores de función o electrónicos no son aptos para el corte de la red eléctrica. Si los productos sin interruptor están integrados en bastidores o instalaciones, se deberá colocar el interruptor en el nivel de la instalación.
5. No utilice nunca el producto si está dañado el cable de conexión a red. Compruebe regularmente el correcto estado de los cables de conexión a red. Asegúrese, mediante las medidas de protección y de instalación adecuadas, de que el cable de conexión a red no pueda ser dañado o de que nadie pueda ser dañado por él, p. ej. al tropezar o por un choque eléctrico.
6. Solamente está permitido el funcionamiento en redes de alimentación TN/TT aseguradas con fusibles de 16 A como máximo (utilización de fusibles de mayor amperaje solo previa consulta con el grupo de empresas Rohde & Schwarz).
7. Nunca conecte el enchufe en tomas de corriente sucias o llenas de polvo. Introduzca el enchufe por completo y fuertemente en la toma de corriente. La no observación de estas medidas puede provocar chispas, fuego y/o lesiones.
8. No sobrecargue las tomas de corriente, los cables alargadores o las regletas de enchufe ya que esto podría causar fuego o choques eléctricos.
9. En las mediciones en circuitos de corriente con una tensión $U_{\text{eff}} > 30 \text{ V}$ se deberán tomar las medidas apropiadas para impedir cualquier peligro (p. ej. medios de medición adecuados, seguros, limitación de tensión, corte protector, aislamiento etc.).
10. Para la conexión con dispositivos informáticos como un PC o un ordenador industrial, debe comprobarse que éstos cumplan los estándares IEC60950-1/EN60950-1 o IEC61010-1/EN 61010-1 válidos en cada caso.
11. A menos que esté permitido expresamente, no retire nunca la tapa ni componentes de la carcasa mientras el producto esté en servicio. Esto pone a descubierto los cables y componentes eléctricos y puede causar lesiones, fuego o daños en el producto.

12. Si un producto se instala en un lugar fijo, se deberá primero conectar el conductor de protección fijo con el conductor de protección del producto antes de hacer cualquier otra conexión. La instalación y la conexión deberán ser efectuadas por un electricista especializado.
13. En el caso de dispositivos fijos que no estén provistos de fusibles, interruptor automático ni otros mecanismos de seguridad similares, el circuito de alimentación debe estar protegido de modo que todas las personas que puedan acceder al producto, así como el producto mismo, estén a salvo de posibles daños.
14. Todo producto debe estar protegido contra sobretensión (debida p. ej. a una caída del rayo) mediante los correspondientes sistemas de protección. Si no, el personal que lo utilice quedará expuesto al peligro de choque eléctrico.
15. No debe introducirse en los orificios de la caja del aparato ningún objeto que no esté destinado a ello. Esto puede producir cortocircuitos en el producto y/o puede causar choques eléctricos, fuego o lesiones.
16. Salvo indicación contraria, los productos no están impermeabilizados (ver también el capítulo "Estados operativos y posiciones de funcionamiento", punto 1). Por eso es necesario tomar las medidas necesarias para evitar la entrada de líquidos. En caso contrario, existe peligro de choque eléctrico para el usuario o de daños en el producto, que también pueden redundar en peligro para las personas.
17. No utilice el producto en condiciones en las que pueda producirse o ya se hayan producido condensaciones sobre el producto o en el interior de éste, como p. ej. al desplazarlo de un lugar frío a otro caliente. La entrada de agua aumenta el riesgo de choque eléctrico.
18. Antes de la limpieza, desconecte por completo el producto de la alimentación de tensión (p. ej. red de alimentación o batería). Realice la limpieza de los aparatos con un paño suave, que no se deshilache. No utilice bajo ningún concepto productos de limpieza químicos como alcohol, acetona o diluyentes para lacas nitrocelulósicas.

Funcionamiento

1. El uso del producto requiere instrucciones especiales y una alta concentración durante el manejo. Debe asegurarse que las personas que manejen el producto estén a la altura de los requerimientos necesarios en cuanto a aptitudes físicas, psíquicas y emocionales, ya que de otra manera no se pueden excluir lesiones o daños de objetos. El empresario u operador es responsable de seleccionar el personal usuario apto para el manejo del producto.
2. Antes de desplazar o transportar el producto, lea y tenga en cuenta el capítulo "Transporte".
3. Como con todo producto de fabricación industrial no puede quedar excluida en general la posibilidad de que se produzcan alergias provocadas por algunos materiales empleados, los llamados alérgenos (p. ej. el níquel). Si durante el manejo de productos Rohde & Schwarz se producen reacciones alérgicas, como p. ej. irritaciones cutáneas, estornudos continuos, enrojecimiento de la conjuntiva o dificultades respiratorias, debe avisarse inmediatamente a un médico para investigar las causas y evitar cualquier molestia o daño a la salud.
4. Antes de la manipulación mecánica y/o térmica o el desmontaje del producto, debe tenerse en cuenta imprescindiblemente el capítulo "Eliminación", punto 1.

5. Ciertos productos, como p. ej. las instalaciones de radiocomunicación RF, pueden a causa de su función natural, emitir una radiación electromagnética aumentada. Deben tomarse todas las medidas necesarias para la protección de las mujeres embarazadas. También las personas con marcapasos pueden correr peligro a causa de la radiación electromagnética. El empresario/operador tiene la obligación de evaluar y señalizar las áreas de trabajo en las que exista un riesgo elevado de exposición a radiaciones.
6. Tenga en cuenta que en caso de incendio pueden desprenderse del producto sustancias tóxicas (gases, líquidos etc.) que pueden generar daños a la salud. Por eso, en caso de incendio deben usarse medidas adecuadas, como p. ej. máscaras antigás e indumentaria de protección.
7. En caso de que un producto Rohde & Schwarz contenga un producto láser (p. ej. un lector de CD/DVD), no debe usarse ninguna otra configuración o función aparte de las descritas en la documentación del producto, a fin de evitar lesiones (p. ej. debidas a irradiación láser).

Reparación y mantenimiento

1. El producto solamente debe ser abierto por personal especializado con autorización para ello. Antes de manipular el producto o abrirlo, es obligatorio desconectarlo de la tensión de alimentación, para evitar toda posibilidad de choque eléctrico.
2. El ajuste, el cambio de partes, el mantenimiento y la reparación deberán ser efectuadas solamente por electricistas autorizados por Rohde & Schwarz. Si se reponen partes con importancia para los aspectos de seguridad (p. ej. el enchufe, los transformadores o los fusibles), solamente podrán ser sustituidos por partes originales. Después de cada cambio de partes relevantes para la seguridad deberá realizarse un control de seguridad (control a primera vista, control del conductor de protección, medición de resistencia de aislamiento, medición de la corriente de fuga, control de funcionamiento). Con esto queda garantizada la seguridad del producto.

Baterías y acumuladores o celdas

Si no se siguen (o se siguen de modo insuficiente) las indicaciones en cuanto a las baterías y acumuladores o celdas, pueden producirse explosiones, incendios y/o lesiones graves con posible consecuencia de muerte. El manejo de baterías y acumuladores con electrolitos alcalinos (p. ej. celdas de litio) debe seguir el estándar EN 62133.

1. No deben desmontarse, abrirse ni triturarse las celdas.
2. Las celdas o baterías no deben someterse a calor ni fuego. Debe evitarse el almacenamiento a la luz directa del sol. Las celdas y baterías deben mantenerse limpias y secas. Limpiar las conexiones sucias con un paño seco y limpio.
3. Las celdas o baterías no deben cortocircuitarse. Es peligroso almacenar las celdas o baterías en estuches o cajones en cuyo interior puedan cortocircuitarse por contacto recíproco o por contacto con otros materiales conductores. No deben extraerse las celdas o baterías de sus embalajes originales hasta el momento en que vayan a utilizarse.
4. Mantener baterías y celdas fuera del alcance de los niños. En caso de ingestión de una celda o batería, avisar inmediatamente a un médico.
5. Las celdas o baterías no deben someterse a impactos mecánicos fuertes indebidos.

6. En caso de falta de estanqueidad de una celda, el líquido vertido no debe entrar en contacto con la piel ni los ojos. Si se produce contacto, lavar con agua abundante la zona afectada y avisar a un médico.
7. En caso de cambio o recarga inadecuados, las celdas o baterías que contienen electrolitos alcalinos (p. ej. las celdas de litio) pueden explotar. Para garantizar la seguridad del producto, las celdas o baterías solo deben ser sustituidas por el tipo Rohde & Schwarz correspondiente (ver lista de recambios).
8. Las baterías y celdas deben reciclarse y no deben tirarse a la basura doméstica. Las baterías o acumuladores que contienen plomo, mercurio o cadmio deben tratarse como residuos especiales. Respete en esta relación las normas nacionales de eliminación y reciclaje.

Transporte

1. El producto puede tener un peso elevado. Por eso es necesario desplazarlo o transportarlo con precaución y, si es necesario, usando un sistema de elevación adecuado (p. ej. una carretilla elevadora), a fin de evitar lesiones en la espalda u otros daños personales.
2. Las asas instaladas en los productos sirven solamente de ayuda para el transporte del producto por personas. Por eso no está permitido utilizar las asas para la sujeción en o sobre medios de transporte como p. ej. grúas, carretillas elevadoras de horquilla, carros etc. Es responsabilidad suya fijar los productos de manera segura a los medios de transporte o elevación. Para evitar daños personales o daños en el producto, siga las instrucciones de seguridad del fabricante del medio de transporte o elevación utilizado.
3. Si se utiliza el producto dentro de un vehículo, recae de manera exclusiva en el conductor la responsabilidad de conducir el vehículo de manera segura y adecuada. El fabricante no asumirá ninguna responsabilidad por accidentes o colisiones. No utilice nunca el producto dentro de un vehículo en movimiento si esto pudiera distraer al conductor. Asegure el producto dentro del vehículo debidamente para evitar, en caso de un accidente, lesiones u otra clase de daños.

Eliminación

1. Si se trabaja de manera mecánica y/o térmica cualquier producto o componente más allá del funcionamiento previsto, pueden liberarse sustancias peligrosas (polvos con contenido de metales pesados como p. ej. plomo, berilio o níquel). Por eso el producto solo debe ser desmontado por personal especializado con formación adecuada. Un desmontaje inadecuado puede ocasionar daños para la salud. Se deben tener en cuenta las directivas nacionales referentes a la eliminación de residuos.
2. En caso de que durante el trato del producto se formen sustancias peligrosas o combustibles que deban tratarse como residuos especiales (p. ej. refrigerantes o aceites de motor con intervalos de cambio definidos), deben tenerse en cuenta las indicaciones de seguridad del fabricante de dichas sustancias y las normas regionales de eliminación de residuos. Tenga en cuenta también en caso necesario las indicaciones de seguridad especiales contenidas en la documentación del producto. La eliminación incorrecta de sustancias peligrosas o combustibles puede causar daños a la salud o daños al medio ambiente.

Qualitätszertifikat

Certificate of quality

Certificat de qualité

Certified Quality System
ISO 9001

Certified Environmental System
ISO 14001

Sehr geehrter Kunde,

Sie haben sich für den Kauf eines Rohde&Schwarz-Produktes entschieden. Hiermit erhalten Sie ein nach modernsten Fertigungsmethoden hergestelltes Produkt. Es wurde nach den Regeln unseres Qualitätsmanagementsystems entwickelt, gefertigt und geprüft. Das Rohde&Schwarz-Qualitätsmanagementsystem ist u.a. nach ISO9001 und ISO 14001 zertifiziert.

Der Umwelt verpflichtet

- ▮ Energie-effiziente, RoHS-konforme Produkte
- ▮ Kontinuierliche Weiterentwicklung nachhaltiger Umweltkonzepte
- ▮ ISO 14001-zertifiziertes Umweltmanagementsystem

Dear Customer,

You have decided to buy a Rohde&Schwarz product. You are thus assured of receiving a product that is manufactured using the most modern methods available. This product was developed, manufactured and tested in compliance with our quality management system standards. The Rohde&Schwarz quality management system is certified according to standards such as ISO9001 and ISO 14001.

Environmental commitment

- ▮ Energy-efficient products
- ▮ Continuous improvement in environmental sustainability
- ▮ ISO 14001-certified environmental management system

Cher client,

Vous avez choisi d'acheter un produit Rohde&Schwarz. Vous disposez donc d'un produit fabriqué d'après les méthodes les plus avancées. Le développement, la fabrication et les tests respectent nos normes de gestion qualité. Le système de gestion qualité de Rohde&Schwarz a été homologué, entre autres, conformément aux normes ISO9001 et ISO 14001.

Engagement écologique

- ▮ Produits à efficience énergétique
- ▮ Amélioration continue de la durabilité environnementale
- ▮ Système de gestion de l'environnement certifié selon ISO 14001

Customer Support

Technical support – where and when you need it

For quick, expert help with any Rohde & Schwarz equipment, contact one of our Customer Support Centers. A team of highly qualified engineers provides telephone support and will work with you to find a solution to your query on any aspect of the operation, programming or applications of Rohde & Schwarz equipment.

Up-to-date information and upgrades

To keep your instrument up-to-date and to be informed about new application notes related to your instrument, please send an e-mail to the Customer Support Center stating your instrument and your wish. We will take care that you will get the right information.

USA & Canada

Monday to Friday (except US public holidays)
8:00 AM – 8:00 PM Eastern Standard Time (EST)

Tel. from USA 888-test-rsa (888-837-8772) (opt 2)
From outside USA +1 410 910 7800 (opt 2)
Fax +1 410 910 7801

E-mail CustomerSupport@rohde-schwarz.com

East Asia

Monday to Friday (except Singaporean public holidays)
8:30 AM – 6:00 PM Singapore Time (SGT)

Tel. +65 6 513 0488
Fax +65 6 846 1090

E-mail CustomerSupport@rohde-schwarz.com

Rest of the World

Monday to Friday (except German public holidays)
08:00 – 17:00 Central European Time (CET)

Tel. +49 89 4129 13774
Fax +49 (0) 89 41 29 637 78

E-mail CustomerSupport@rohde-schwarz.com



ROHDE & SCHWARZ

Address List

Headquarters, Plants and Subsidiaries

Headquarters

ROHDE & SCHWARZ GmbH & Co. KG
Mühlendorfstraße 15 · D-81671 München
P.O.Box 80 14 69 · D-81614 München

Phone +49 (89) 41 29-0
Fax +49 (89) 41 29-121 64
info.rs@rohde-schwarz.com

Plants

ROHDE & SCHWARZ Messgerätebau GmbH
Riedbachstraße 58 · D-87700 Memmingen
P.O.Box 16 52 · D-87686 Memmingen

Phone +49 (83 31) 1 08-0
+49 (83 31) 1 08-1124
info.rsmb@rohde-schwarz.com

ROHDE & SCHWARZ GmbH & Co. KG
Werk Teisnach
Kaikenrieder Straße 27 · D-94244 Teisnach
P.O.Box 11 49 · D-94240 Teisnach

Phone +49 (99 23) 8 50-0
Fax +49 (99 23) 8 50-174
info.rsdt@rohde-schwarz.com

ROHDE & SCHWARZ závod
Vimperk, s.r.o.
Location Spidrova 49
CZ-38501 Vimperk

Phone +420 (388) 45 21 09
Fax +420 (388) 45 21 13

ROHDE & SCHWARZ GmbH & Co. KG
Dienstleistungszentrum Köln
Graf-Zeppelin-Straße 18 · D-51147 Köln
P.O.Box 98 02 60 · D-51130 Köln

Phone +49 (22 03) 49-0
Fax +49 (22 03) 49 51-229
info.rsdc@rohde-schwarz.com
service.rsdc@rohde-schwarz.com

Subsidiaries

R&S BICK Mobilfunk GmbH
Fritz-Hahne-Str. 7 · D-31848 Bad Münder
P.O.Box 20 02 · D-31844 Bad Münder

Phone +49 (50 42) 9 98-0
Fax +49 (50 42) 9 98-105
info.bick@rohde-schwarz.com

ROHDE & SCHWARZ FTK GmbH
Wendenschloßstraße 168, Haus 28
D-12557 Berlin

Phone +49 (30) 658 91-122
Fax +49 (30) 655 50-221
info.ftk@rohde-schwarz.com

ROHDE & SCHWARZ SIT GmbH
Am Studio 3
D-12489 Berlin

Phone +49 (30) 658 84-0
Fax +49 (30) 658 84-183
info.sit@rohde-schwarz.com

R&S Systems GmbH
Graf-Zeppelin-Straße 18
D-51147 Köln

Phone +49 (22 03) 49-5 23 25
Fax +49 (22 03) 49-5 23 36
info.rssys@rohde-schwarz.com

GEDIS GmbH
Sophienblatt 100
D-24114 Kiel

Phone +49 (431) 600 51-0
Fax +49 (431) 600 51-11
sales@gedis-online.de

HAMEG Instruments GmbH
Industriestraße 6
D-63533 Mainhausen

Phone +49 (61 82) 800-0
Fax +49 (61 82) 800-100
info@hameg.de

Locations Worldwide

Please refer to our homepage: www.rohde-schwarz.com

- ◆ Sales Locations
- ◆ Service Locations
- ◆ National Websites

Contents of Manual for Vector Signal Analysis Software R&S FSQ-K70/FSMR-B73/FSU-B73

The present manual describes operation of the Signal Analyzer R&S FSQ, the Signal Source Analyzer R&S FSUP, the Measuring Receiver R&S FSMR and the Spectrum Analyzers R&S FSU and R&S FSG with application firmware R&S FSQ-K70/FSMR-B73/FSU-B73. The manual includes descriptions of menus and remote-control commands for vector signal analysis.

The manual comprises a data sheet and 10 chapters:

Data Sheet Informs on specifications and firmware characteristics.

Chapter 1 Describes enabling of the firmware.

Chapter 2 Describes first measurements with the aid of simple examples.

Chapter 3 Provides a functional overview of firmware functions and measured modulation errors. Describes the test setup for base station tests.

Chapter 4 Provides a schematic overview of R&S FSQ-K70/FSMR-B73/FSU-B73 control menus.

Chapter 5 Provides a detailed description of all functions of the vector signal analysis option as a reference for manual operation. The chapter also lists the IEC/IEEE-bus commands associated with each function.

Chapter 6 Describes all remote-control commands defined for the application. An alphabetic list of all remote-control commands and a table of softkeys and assigned IEC/IEEE commands can be found at the end of the chapter.

Chapter 7 Describes a check of rated characteristics.

Chapter 8 Describes external help programs and utilities.

Chapter 9 Contains an explanation of terms related to vector signal analysis.

Chapter 10 Contains the index of the present operating manual.

This manual complements the analyzer manual or receiver manual. It only describes functions of the Vector Signal Analysis Firmware R&S FSQ-K70/FSMR-B73/FSU-B73. For all other functions, please refer to the operating manual of the signal generator.

Contents

Safety Instructions

Certificate of Quality

EU Certificate of Conformity

R&S Address List

1	Vector Signal Analysis - Application Firmware R&S FSQ-K70/FSMR-B73/FSU-B73	17
	Enabling the Firmware Option	17
	Test Setup for Measurement on Base Stations and Power Amplifiers	18
	Precautions	18
	Standard Test Setup	18
	Calling and Exiting the Option - VSA Softkey	19
	Calling the Option - VSA Softkey	19
	Exiting the Option - VSA Softkey	19
	Return to VSA Menu (Home VSA Hotkey)	19
	Overview	20
2	First Measurements - Getting Started	21
	Interconnecting Transmitter and Analyzer	21
	Basic Settings of Test Transmitter	22
	Switching On the R&S FSQ-K70/FSMR-B73/FSU-B73 Option	23
	Basic Analyzer settings for EDGE Measurements	23
	Measurement 1: Demodulation of a Single EDGE Burst	24
	Measurement 2: Selection of a Specific Slot with Trigger Offset	26
	Measurement 3: Setting the Burst Search Parameters (LEVEL)	28
	Measurement 4: Suppression of Incorrect Measurements	30
	Measurement 5: Evaluation Lines	32
3	Brief Description of Vector Signal Analysis (Function)	34
	Block Diagram of Digital Signal Processing Hardware	35
	Description of Block Diagram	35
	Bandwidths for Signal Processing	36
	Analog RBW Filters	37
	I/Q Bandwidth	38
	Demodulation Bandwidth (Measurement Bandwidth)	39
	System-Theoretical Modulation and Demodulation Filters	40
	Design and Use of Customized Filters	42
	Filter for PSK, QAM, USER-QAM and VSB	43
	Filter for FSK / MSK	43
	Adaptive Equalizer Filter	44
	Training process of the equalizer	45
	Symbol Mapping	48
	Phase Shift Keying (PSK)	48

Phase Offset PSK	50
Differential PSK.....	52
Mixed PSK Modulation.....	53
Offset QPSK.....	54
Frequency Shift Keying (FSK).....	56
Minimum Shift Keying (MSK)	57
Quadrature Amplitude Modulation (QAM).....	58
Statistical QAM Mappings	58
Differential QAM Mappings	62
User Defined Constellations (USER-QAM).....	64
Vestigial Sideband Modulation (VSB).....	65
Demodulation and Algorithms	67
Burst Search	70
Demodulator 1.....	72
Timing Recovery	72
Phase & Frequency Recovery	72
Demodulator 2.....	74
Matching.....	76
Pattern Search	78
Result & Error Calculation, Display.....	80
Differences between Modulation Types.....	82
Vector and Scalar Modulation Errors	83
Error Model of Transmitter	83
Modulation Error (PSK, MSK, QAM, VSB).....	84
Error vector (EV)	84
Error vector Magnitude (EVM)	84
Phase error	85
IQ-Offset (Origin Offset).....	86
Gain Imbalance	87
Quadrature Imbalance	88
Gain Distortion	89
Phase Distortion.....	90
Noise	91
Modulation Error (FSK).....	92
4 Operation and Menu Overview.....	94
Operation.....	94
Special Features/Differences from the Basic Instrument	94
Display of States Within Softkeys	94
Display of Setting Parameters Within Softkeys.....	95
Measurement Window	97
Warnings and Messages of Signal Processing Stages	98
Discarding a Measurement	98
Menu Overview	99
Hotkeys	99
Assignment of the Hotkey Bar of the Basic Instrument	99
Assignment of the Hotkey Bar of the Option.....	99
Softkeys.....	99

5 Instrument Settings and Measurements	105
Resetting the Option - PRESET VSA Hotkey.....	105
Overview of Current Settings - SETTINGS Hotkey	105
Configuration of Measurements - HOME VSA Hotkey.....	106
Measurements on Dig. Standards - DIG. STANDARD Softkey	107
Predefined Standards and Standard Groups.....	107
List of Predefined Standards and Standard Groups	109
DIGITAL STANDARD Menu	112
Exiting a Standard.....	116
BURST& PATTERN Softkey	117
Burst and Search Parameters.....	117
Multiple Evaluation of a Captured Data Record (MULTI)	119
Controlling the Evaluation	120
Controlling Data Capture	123
Burst and Search Parameters for Predefined Standards	124
Pattern and Pattern Lists.....	125
Predefined Patterns and List Structures	125
Extending the Pattern List.....	125
Creating a New Pattern.....	125
Deleting and Removing a Pattern	125
Pattern Search List.....	126
BURST& PATTERN Menu.....	127
Sync Patterns and Pattern Lists.....	133
Creating and Editing Sync Patterns	135
Display of Pattern in Data Stream.....	138
Setting Parameters - MODULATION SETTINGS Softkey.....	139
Setting Demodulation - DEMOD SETTINGS Softkey	147
Evaluation Lines / Limiting the Measurement Range	150
Record Buffer, Demodulation Range and Display Range	151
Display of Measurement Results	153
Spectral Displays	153
Statistical Displays	154
MEAS RESULT Softkey.....	155
Selection of Displayed Measurement and Reference Signal - MEAS SIGNAL / REF SIGNAL Softkey	162
Selection of Error Display - ERROR SIGNAL Softkey.....	177
Selection of the Raw Signal - CAPTURE BUFFER Softkey	194
Selection of Adaptive Equalizer Display - EQUALIZER Softkey.....	204
Positioning of Display on Screen - FIT TRACE Softkey	212
Scaling of Time Axis in Symbols.....	215
FIT TRACE Menu.....	216
Multiple Evaluation and Section Displays - ZOOM Softkey	217
Setting of Span - RANGE Softkey	218
Automatic Setting of Reference Level - ADJUST LVL Softkey.....	220
Restoring of Factory Settings - FACTORY DEFAULTS Softkey	221
Importing Stand., Mappings, Pattern and Filter - IMPORT Softkey.....	222

Export of Stand., Mappings, Pattern and Filter - EXPORT Softkey	225
Overview of Other Menus	228
Default Settings - PRESET Key	228
System Error Correction - CAL Key	228
General Instrument Settings - SETUP Key	229
Documentation of Results - HCOPY Key	231
Frequency Settings - FREQ Key	232
Span - SPAN Key	232
Level Settings - AMPT Key	233
Selection of Units for Display - DISPLAY UNIT Key	234
Setting of Bandwidth for Analog IF Filter - BW Key	235
Sweep Settings - Sweep Key	236
MEAS Key	238
Trigger Settings - TRIGGER Key	238
Trace Functions - TRACE Key	239
Limit Lines Settings - LINES Key	243
Screen Configuration - DISP Key	244
File Management - FILE Key	245
Marker Settings - MARKER Key	246
Marker Settings (Marker to) - MKR -> Key	247
Marker Functions - MKR FCTN Key	247
Menu MKR FCTN - SUMMARY MARKER	249
Troubleshooting	254
Different Symbol Rate Setting in Transmitter and Analyzer	254
Different Filter Settings in Transmitter and Analyzer	255
Incorrect Modulation of Analyzer	256
Overdrive Condition of the Analyzer	257
6 Remote Control Commands	258
CALCulate Subsystem	258
CALCulate:DDEM Subsystem	259
CALCulate:FEED Subsystem	260
CALCulate:FORMat Subsystem	261
CALCulate:ELIN Subsystem	263
CALCulate:MARKer:FUNCTion Subsystem	264
CALCulate:STATistics Subsystem	286
CALCulate:TRACe Subsystem	287
CALCulate:UNIT Subsystem	288
DISPlay Subsystem	289
FORMat Subsystem	291
INSTrument Subsystem	293
MMEMory - Subsystem	294
SENSe Subsystem	296
SENSe:DDEMod Subsystem	296
SENSe:FREQuency Subsystem	321

TRACe Subsystem	322
TRIGger Subsystem	325
Table of Softkeys Assigned to IEC/IEEE Bus Commands	326
Hotkey VSA	326
Hotkeys of Option	326
Menu DIGITAL STANDARD	326
Menu MODULATION SETTINGS	328
Menu DEMOD SETTINGS	329
Menu BURST & PATTERN	331
Menu MEAS RESULTS	333
Menu FIT TRACE	335
Menu ZOOM	336
Menu RANGE	337
Menu FACTORY DEFAULTS	337
Menu IMPORT	338
Menu EXPORT	338
FREQ Key	339
SPAN Key	339
AMPT Key	339
MKR Key	341
MKR -> Key	341
MKR FCTN Key	342
BW Key	343
SWEEP Key	343
MEAS Key - not available	343
TRIG Key	344
TRACE Key	344
LINES Key	345
DISP Key	347
FILE Key	348
CAL Key	349
SETUP Key	349
HCOPY Key	351
Hotkey Bar	351
Status-QUESTIONable:SYNC Register	352
STATus-QUESTIONable:POWER Register	352
7 Checking the Rated Specifications	353
Required Test Equipment and Accessories	353
Test Sequence	353
8 Utilities /External Programs	355
Mapping Editor (MAPWIZ)	355
Filter Tool (FILTWIZ)	356
9 Glossary and Formulae	357
Trace-based Evaluations	357

Summary - Evaluations.....358
Statistical Evaluations360
Trace Averaging and Marker Functions.....360
Averaging RMS Quantities360
Analytically Calculated Filters361
Standard-Specific Filters362
Abbreviations Used.....363
10Index..... 364

Figures

Fig. 1	Hotkey bar of basic unit with option R&S FSQ-K70/FSMR-B73/FSU-B73 installed.	17
Fig. 2	Connection to RF output of a base station (for example R&S FSQ).....	18
Fig. 3	Hotkey bar when option R&S FSQ-K70/FSMR-B73/FSU-B73 is active	19
Fig. 4	Overview: calling and exiting option FSQ-K70/FSMR/FSU-B73	20
Fig. 5	Connection to a test transmitter (for example R&S FSQ)	21
Fig. 6	Measurement 1: Frame structure	24
Fig. 7	Measurement 1: Result display of analyzer	25
Fig. 8	Measurement 1: I/Q vector	25
Fig. 9	Measurement 1: RESULT RAW	25
Fig. 10	Meas. 2: Magnitude capture buffer.....	27
Fig. 11	Meas. 2: EDGE_TSC0	27
Fig. 12	Meas. 2: FIT TRIGGER TO LEFT	27
Fig. 13	Meas. 2: FIT PATTERN TO LEFT.....	27
Fig. 14	Burst search parameter	28
Fig. 15	Meas. 3: Burst search AUTO, EDGE_TSC4	29
Fig. 16	Meas. 3: Burst search AUTO, EDGE_TSC3	29
Fig. 17	Meas. 3: Burst search, manual level setting.....	29
Fig. 18	Meas. 4: EDGE demodulator, correct demodulation.....	31
Fig. 19	Meas. 4: EDGE demodulator, incorrect demodulation of a GSM burst.....	31
Fig. 20	Meas. 5: Setting the evaluation range: presetting the standard	33
Fig. 21	Meas. 5: Setting the evaluation range: extension to burst edges	33
Fig. 22	Meas. 5: Level distribution within the burst	33
Fig. 23	Meas. 5: Level distribution within and outside the burst.....	33
Fig. 24	Block diagram of digital hardware for vector signal analysis.....	35
Fig. 25	Block diagram with the signal processing of the R&S FSQ at sampling rates >81.6 MHz. ...	36
Fig. 26	Block diagram of bandwidth-relevant filters for vector signal analysis	36
Fig. 27	Selected oversampling rates (I/Q bandwidth, interference)	39
Fig. 28	Block diagram of filters in the PSK mode (RESULT = FILT setting)	40
Fig. 29	Block diagram of filters in the PSK mode (RESULT = RAW setting)	40
Fig. 30	Block diagram of filter stages in the MSK and FSK modes.....	42
Fig. 31	Generation of baseband transmit signal (PSK, QAM, USER-QAM and VSB).....	43
Fig. 32	Generation of transmit signals (FSK, MSK)	43
Fig. 33	Base band schematic of the modulation- and demodulation stages.....	44
Fig. 34	Base band schematic: compensation of the transfer function's error by inserting an adaptive equalizer in the receive path.....	44
Fig. 35	Base band schematic: compensation of the transfer function's error by inserting an adaptive equalizer in the receive path.....	45
Fig. 36	Optimisation range of the adaptive equalizer filter	47
Fig. 37	Upper diagram: frequency response of a trained equalizer filter (bad SNR at the instrument's input)	48
Fig. 38	Upper diagram: frequency response of a trained equalizer filter (good SNR)	48
Fig. 39	Symbol mapping – BPSK / NATURAL	49
Fig. 40	Symbol mapping – QPSK / WCDMA.....	49
Fig. 41	Symbol mapping – QPSK / NATURAL.....	49
Fig. 42	Symbol mapping – QPSK / CDMA2K_FWD	49
Fig. 43	Symbol mapping – 8PSK / NATURAL.....	49
Fig. 44	I/Q symbol stream before $3\pi/8$ rotation	50
Fig. 45	I/Q symbol stream after $3\pi/8$ rotation	50
Fig. 46	Logical symbol mapping – $3\pi/8$ -8PSK / EDGE	51
Fig. 47	Physical constellation diagram with ISI-free demodulation (taking into account the $3\pi/8$ phase offset).....	51
Fig. 48	EDGE TX filter	51
Fig. 49	Vector diagram: transmitted EDGE signal.....	51
Fig. 50	Logical symbol mapping – DQPSK / INMARSAT.....	52
Fig. 51	Physical constellation diagram – DQPSK / INMARSAT.....	52
Fig. 52	Logical symbol mapping – D8PSK / NATURAL	52

Fig. 53	Physical constellation diagram – D8PSK / NATURAL	52
Fig. 54	Logical mapping – (NADC, PDC, PHS, TETRA).....	53
Fig. 55	Physical constellation diagram – $\pi/4$ -DQPSK (NADC, PDC, PHS, TETRA); the $\pi/4$ phase offset is taken into account	53
Fig. 56	Logical mapping – $\pi/4$ DQPSK (TFTS)	53
Fig. 57	Physical constellation diagram – $\pi/4$ DQPSK (TFTS); the $\pi/4$ phase offset is taken into account	53
Fig. 58	PSK vector diagram with $\alpha = 0.35$	54
Fig. 59	OQPSK vector diagram with $\alpha = 0.35$	54
Fig. 60	Logical symbol mapping – OQPSK / CDMA2K_REV	55
Fig. 61	Symbol mapping – 2FSK / NATURAL	56
Fig. 62	Symbol mapping – 4FSK / NATURAL	56
Fig. 63	Logical symbol mapping – MSK / NATURAL	57
Fig. 64	Physical constellation diagram – MSK	57
Fig. 65	DMSK: differential encoder in the transmitter	57
Fig. 66	Rotation of 1st quadrant	58
Fig. 67	Symbol mapping – 16QAM / DVB-C	58
Fig. 68	Symbol mapping – 32QAM / DVB-C	59
Fig. 69	Symbol mapping – 64QAM / DVB-C	59
Fig. 70	Symbol mapping – 128QAM / DVB-C	60
Fig. 71	Symbol mapping – 265QAM / DVB-C	61
Fig. 72	Symbol mapping – D16QAM / DVB-C.....	62
Fig. 73	Symbol mapping – D32QAM / DVB-C.....	62
Fig. 74	Symbol mapping – D64QAM / DVB-C.....	62
Fig. 75	Symbol mapping – D128QAM / DVB-C.....	63
Fig. 76	Symbol mapping – D256QAM / DVB-C.....	63
Fig. 77	Demodulation of a 16ary USER-QAM.....	64
Fig. 78	8VSB constellation diagram	65
Fig. 79	8VSB spectrum at the input of the analyzer (pilot carrier visible to the left).....	66
Fig. 80	Spectrum of measurement signal 8VSB (pilot carrier always removed).....	66
Fig. 81	Symbol mapping 8VSB (ATSC).....	66
Fig. 82	Digital demodulation of a PSK demodulator.....	67
Fig. 83	Burst Search	69
Fig. 84	Record buffer containing several bursts	70
Fig. 85	I/Q demodulator: timing, phase, frequency recovery.....	71
Fig. 86	Symbol timing detection & correction	72
Fig. 87	Demodulator 2	73
Fig. 88	QPSK segment decider	74
Fig. 89	Matching	75
Fig. 90	Pattern search	77
Fig. 91	Pattern search for static QPSK mapping.....	78
Fig. 92	Result & Error Calculation	79
Fig. 93	Trace averaging.....	80
Fig. 94	Averaging of scalar parameters.....	80
Fig. 95	Result display	81
Fig. 96	Modulation error: error model of transmitter and transmission path	83
Fig. 97	Modulation error: error vector	84
Fig. 98	Modulation error: EVM, magnitude error	84
Fig. 99	Modulation error: error vector phase, phase error.....	85
Fig. 100	Modulation error: origin offset (I/Q offset).....	86
Fig. 101	Modulation error: compensation of origin offset	86
Fig. 102	Modulation error: gain imbalance (transmitter).....	87
Fig. 103	Modulation error: gain imbalance (analyzer)	87
Fig. 104	Modulation error: quadrature imbalance (transmitter).....	88
Fig. 105	Modulation error: quadrature imbalance (analyzer)	88
Fig. 106	Modulation error: I/Q imbalance	88
Fig. 107	Nonlinear distortions: amplitude distortion (transmitter).....	89
Fig. 108	Amplitude distortion (analyzer).....	89

Fig. 109	Amplitude transfer function (transmitter)	89
Fig. 110	Amplitude transfer function (analyzer).....	89
Fig. 111	Nonlinear distortions: phase distortion (transmitter).....	90
Fig. 112	Phase distortion (analyzer).....	90
Fig. 113	Nonlinear distortions: phase distortion (transmitter).....	90
Fig. 114	Phase distortions (analyzer).....	90
Fig. 115	Additive noise	91
Fig. 116	Modulation error: reference signal (REFDEVCOMP = OFF) and measurement signal.....	92
Fig. 117	Modulation error: frequency error, reference signal not normalized	92
Fig. 118	Modulation error: reference signal normalized	93
Fig. 119	Modulation error: frequency error, reference signal normalized	93
Fig. 120	Result display split screen <i>EVM</i> (upper diagram) <i>ERROR STATISTIC + EVM</i> (lower diagram).....	96
Fig. 121	Result display split screen <i>EVM</i> (upper diagram) <i>ERROR SPECTRUM + EVM</i> (lower diagram).....	96
Fig. 122	Measurement window of the R&S FSQ-K70/FSMR-B73/FSU-B73 option	97
Fig. 123	Hotkey bar of the basic instrument with the R&S FSQ-K70/FSMR-B73/FSU-B73 option installed.....	99
Fig. 124	Hotkey bar with the R&S FSQ-K70/FSMR-B73/FSU-B73 option switched on	99
Fig. 125	Overview of vector analysis settings	105
Fig. 126	Standard definition and grouping in groups.....	108
Fig. 127	Standard window	112
Fig. 128	Standard window	114
Fig. 129	Definition of a standard group	115
Fig. 130	Burst model of analyzer, where grey fields are operating parameters.....	117
Fig. 131	<i>MULTI ON/MULTI OFF</i> : Multiple measurement evaluations per data capture	119
Fig. 132	Screenshot of multiple processing. Upper trace: Capture buffer magnitude (zoomed view), Lower trace: Measurement signal magnitude	120
Fig. 133	<i>DEMOD NEXT RIGHT</i> : Demodulation of the adjacent signal section	121
Fig. 134	<i>DEMOD NEXT RIGHT</i> Burst signal, demodulation of the next burst signal	121
Fig. 135	<i>DEMOD NEXT RIGHT</i> : Automatic shifting of the ZOOM area.....	121
Fig. 136	<i>DEMOD @ ZOOM START</i> : Reset to the start of the zoom window	122
Fig. 137	<i>DEMOD RESTART</i> : Reset to the start of the record buffer	122
Fig. 138	<i>COUNTINUOUS SWEEP</i> : Automatic data capture.....	123
Fig. 139	<i>SINGLE SWEEP</i> : Automatic data capture at end of the record buffer if CAPTURE = AUTO.....	123
Fig. 140	Pattern lists.....	126
Fig. 141	Settings of burst search.....	130
Fig. 142	Pattern Select.....	131
Fig. 143	Pattern Select'.....	132
Fig. 144	Pattern selection tables	133
Fig. 145	Expanding pattern lists	134
Fig. 146	Entry fields for <i>EDIT PATTERN</i>	135
Fig. 147	Display of pattern in the table of decoded symbols.....	138
Fig. 148	Modulation mode FSK,-> 2FSK, 4FSK.....	140
Fig. 149	Modulation mode MSK,-> DMSK,MSK.....	140
Fig. 150	Modulation mode PSK,-> BPSK,QPSK, OQPSK, 8PSK, DQPSK, D8PSK, pi/4 DQPSK, 3pi/8-8PSK.....	141
Fig. 151	Modulation mode QAM,-> 16QAM ... 256 QAM (regular, and cross structure)	141
Fig. 152	Filter selection list	142
Fig. 153	Filename input	144
Fig. 154	Definition of a new filter set	145
Fig. 155	Setting the <i>EVAL RANGE</i>	150
Fig. 156	Record buffer burst search range and result display	151
Fig. 157	Spectrum diagram: Single-sided display for real input signals.....	153
Fig. 158	Spectrum diagram: Two-sided display for complex input signals	153
Fig. 159	Error vector magnitude (top) EVM frequency distribution (bottom).....	154
Fig. 160	Modulation Accuracy (single screen, Trace Average = off).....	157

Fig. 161	Modulation Accuracy (single screen, Trace Average = off).....	158
Fig. 162	Modulation Accuracy (split screen, Trace Average = on), indication of decoded symbols..	159
Fig. 163	Result display <i>MAGNITUDE</i>	163
Fig. 164	Result display <i>PHASE (UNWRAP)</i>	164
Fig. 165	Result display <i>PHASE (WRAP)</i>	164
Fig. 166	Result display <i>FREQUENCY (ABS)</i>	165
Fig. 167	Result display <i>REAL/IMAG</i>	166
Fig. 168	Result display <i>EYE</i>	167
Fig. 169	Result display <i>IQ VECT</i>	168
Fig. 170	Result display <i>IQ CONST</i>	168
Fig. 171	Result display <i>SPECTRUM MAGNITUDE</i>	170
Fig. 172	Result display <i>SPECTRUM PHASE</i>	171
Fig. 173	Result display <i>SIGNAL SPECTRUM FREQUENCY</i>	172
Fig. 174	Result display <i>REAL/IMAG (upper diagram)</i> Result display <i>SPECTRUM REAL/IMAG (lower diagram)</i>	173
Fig. 175	Result display <i>SIGNAL STATISTIC MAGNITUDE</i>	174
Fig. 176	Result display <i>SIGNAL STATISTIC MAGNITUDE (log)</i>	174
Fig. 177	Result display <i>SIGNAL STATISTIC PHASE</i>	175
Fig. 178	Result display <i>SIGNAL STATISTIC FREQUENC</i>	176
Fig. 179	<i>MAGNITUDE ERROR</i> result display.....	177
Fig. 180	<i>PHASE ERROR</i> result display.....	178
Fig. 181	<i>FREQ ERROR</i> result display.....	179
Fig. 182	<i>REAL / IMAG</i> result display.....	180
Fig. 183	<i>AM & PM CONVERSION</i> result display (<i>AM-AM upper diagram, AM-PM lower diagram</i>).....	181
Fig. 184	<i>AM & PM CONVERSION</i> result display, marker field).....	181
Fig. 185	<i>EVM</i> (error vector magnitude) result display.....	182
Fig. 186	<i>IQ ERROR</i> result display (constellation diagram).....	183
Fig. 187	<i>IQ ERROR</i> result display (vector display).....	183
Fig. 188	Result display <i>MAGNITUDE ERROR (upper diagram)</i> Result display <i>ERROR SPECTRUM -> MAGNITUDE ERRORR (lower diagram)</i>	185
Fig. 189	Result display <i>PHASE ERROR (upper diagram)</i> Result display <i>ERROR SPECTRUM -> PHASE ERRO (lower diagram)</i>	186
Fig. 190	Result display <i>FREQUENCY ERROR (upper diagram)</i> Result display <i>ERROR SPECTRUM FREQUENCY ERROR (lower diagram)</i>	187
Fig. 191	Result display <i>EVM (upper diagram)</i> Result display <i>ERROR SPECTRUM -> EVM (lower diagram)</i>	188
Fig. 192	Result display <i>REAL/IMAG (upper diagram)</i> Result display <i>ERROR SPECTRUM REAL/IMAG (lower diagram)</i>	189
Fig. 193	<i>ERROR STATISTIC MAGNITUDE</i> result display.....	190
Fig. 194	<i>ERROR STATISTIC PHASE</i> result display.....	191
Fig. 195	<i>ERROR STATISTIC FREQUENCY</i> result display.....	192
Fig. 196	<i>ERROR STATISTIC EVM</i> result display.....	193
Fig. 197	Result display <i>MAGNITUDE CAPTURE BUFFER</i>	195
Fig. 198	Result display <i>MAGNITUDE CAPTURE BUFFER (upper diagram)</i> Result display <i>CAPTURE BUFFER -> FREQUENCY (lower diagram)</i>	196
Fig. 199	Result display <i>MAGNITUDE CAPTURE BUFFER (upper diagram)</i> Result display <i>CAPTURE BUFFER -> REAL/IMAG (lower diagram)</i>	197
Fig. 200	Result display <i>CAPTURE BUFFER MAGNITUDE (upper diagram)</i> Result display <i>SPECTRUM -> CAPTURE BUFFER MAGNITUDE (lower diagram)</i>	198
Fig. 201	Result display <i>CAPTURE BUFFER FREQUENCY (upper diagram)</i> Result display <i>SPECTRUM -> CAPTURE BUFFER FREQUENCY (lower diagram)</i>	199
Fig. 202	Result display <i>CAPTURE BUFFER REAL/IMAG (upper diagram)</i> Result display <i>SPECTRUM -> CAPTURE BUFFER REAL/IMAG (lower diagram)</i>	200
Fig. 203	Result display <i>MAGNITUDE CAPTURE BUFFER (upper diagram)</i> Result display <i>STATISTIC -> MAGNITUDE CAPTURE BUFFER (lower diagram)</i>	201
Fig. 204	Result display <i>FREQUENCY CAPTURE BUFFER (upper diagram)</i> Result display <i>STATISTIC -> FREQUENCY CAPTURE BUFFER (lower diagram)</i>	202

Fig. 205	Result display <i>REAL/IMAG CAPTURE BUFFER</i> (upper diagram) Result display <i>STATISTIC -> REAL/IMAG CAPTURE BUFFER</i> (lower diagram)	203
Fig. 206	Display of the filter coefficients <i>MAGNITUDE (LIN)</i>	205
Fig. 207	Display of the filter coefficients <i>MAGNITUDE (LOG)</i>	205
Fig. 208	Result display <i>PHASE(WRAP)</i>	206
Fig. 209	Result display <i>PHASE(UNWRAP)</i>	206
Fig. 210	Display result <i>REAL/IMAG</i> (impulse response = equalizer's filter coefficients)	207
Fig. 211	Result display <i>GROUP DELAY</i>	208
Fig. 212	Result display <i>PHASE RESPONSE</i>	209
Fig. 213	Result display <i>FREQ RESP (LIN)</i>	210
Fig. 214	Result display <i>FREQ RESP (LOG)</i>	210
Fig. 215	Result display <i>CHAN RESP (LIN)</i>	211
Fig. 216	Result display <i>CHAN RESP (LOG)</i>	211
Fig. 217	Burst measurement by using an external trigger	212
Fig. 218	Examples of FIT: Fit Burst to Left / Center / Right	213
Fig. 219	Examples of FIT: Fit Pattern to Left / Center / Right	213
Fig. 220	Examples of FIT: Fit Burst to Trigger	214
Fig. 221	Examples of FIT: Fit Align	214
Fig. 222	Examples of FIT: scaling of time axis	215
Fig. 223	Examples of FIT: labelling of symbol axis	215
Fig. 224	Example of RANGE, I/Q display X AXIS/DIV is used together with Y AXIS/DIV	219
Fig. 225	Example of RANGE, time display (EVM lin)	219
Fig. 226	Example of RANGE, time display, Mag Cap Buffer	219
Fig. 227	Example of RANGE, statistical display Quantize	219
Fig. 228	Selection list of digital standards EXPORT -> STANDARDS	222
Fig. 229	Selection list of symbol mappings IMPORT -> MAPPINGS	223
Fig. 230	Selection list of filters IMPORT -> FILTERS	223
Fig. 231	Selection list of filters IMPORT -> EQUALIZER	223
Fig. 232	Selection list of synchronization patterns IMPORT -> PATTERNS	223
Fig. 233	Selection of path IMPORT -> PATH	224
Fig. 234	Selection list of digital standards EXPORT -> STANDARDS	225
Fig. 235	Selection list of symbol mappings EXPORT -> MAPPINGS	226
Fig. 236	Selection list of filters EXPORT -> FILTERS	226
Fig. 237	Selection list of filters EXPORT -> EQUALIZER	227
Fig. 238	Selection list of synchronization patterns EXPORT -> PATTERNS	227
Fig. 239	Selection of the path EXPORT -> PATH	227
Fig. 240	AM/AM and AM/PM diagram with calculation of the compression point	248
Fig. 241	Displayed EVM with correct setting of the symbol rate	254
Fig. 242	Displayed EVM with incorrect setting of the symbol rate	254
Fig. 243	Constellation diagram with correct setting of the symbol rate	254
Fig. 244	Constellation diagram with incorrect setting of the symbol rate	254
Fig. 245	Displayed EVM with correct filter settings (decision points only)	255
Fig. 246	Displayed EVM with different filter settings (decision points only)	255
Fig. 247	Displayed error spectrum with correct filter settings	255
Fig. 248	Displayed error spectrum with different filter settings	255
Fig. 249	Constellation diagram with correct modulation	256
Fig. 250	Constellation diagram with superimposed noise in the event of underdrive	256
Fig. 251	Statistical distribution of magnitude error with correct modulation	256
Fig. 252	Statistical distribution of magnitude error in the event of underdrive	256
Fig. 253	Displayed EVM with overdrive condition	257
Fig. 254	Possible AM/PM conversion diagram with overdrive condition	257
Fig. 255	Possible AM/PM conversion diagram with overdrive condition	257
Fig. 256	MAPWIZ -Mapping editor for the R&S FSQ-K70/FSMR-B73/FSU-B73	355
Fig. 257	FILTWIZ - filter tool for the R&S FSQ-K70/FSMR-B73/FSU-B73	356

Tables

Table 1	Basic settings of test transmitter for first measurements	22
Table 2	Transmitter settings for various measurements	22
Table 3	Basic instrument settings.....	23
Table 4	Basic setting for vector signal analysis measurements.....	23
Table 5	RBW filter bandwidths and usable bandwidths	37
Table 6	Maximum I/Q bandwidths of data recording.....	38
Table 7	I/Q bandwidth as a function of POINTS/SYM setting.....	38
Table 8	Typical combinations of TX, ISI and MEAS filters.....	41
Table 9	Warnings displayed in the order of priority	98
Table 10	Meaning of bits in the STATus: QUEstionable:SYNC register.....	352
Table 11	Meaning of bits in the STATus: QUEstionable:POWER register	352
Table 12	Required Measuring Equipment and Accessories	353

Special precautions

Special precautions have to be taken when measurements are performed on mobile radio base stations and output amplifiers of high RF output power. For relevant safety instructions refer to chapter 1, Test Setup for Measurements on Base Stations and Power Amplifiers.

1 Vector Signal Analysis - Application Firmware R&S FSQ-K70/FSMR-B73/FSU-B73

When equipped with application firmware R&S FSQ-K70 or the VSA Extension R&S FSMR/FSU-B73, the Analyzer R&S FSQ/FSU/FSUP or the Measuring Receiver R&S FSMR performs vector measurements on digitally modulated signals in the time domain. Based on the vector measurements, further evaluations, e.g. statistical evaluations or distortion measurements can be performed.

Enabling the Firmware Option

Firmware option R&S FSQ-K70/FSMR-B73/FSU-B73 is enabled by entering a keyword in the *SETUP* → *GENERAL SETUP* menu. The keyword is supplied with the option. If the option is factory-installed, it is already enabled.

GENERAL SETUP menu:

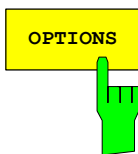

The *OPTIONS* softkey opens a submenu where the keywords for new firmware options (application firmware modules) can be entered. Available options are listed in a table displayed when the submenu is opened.

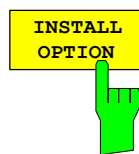

The *INSTALL OPTION* softkey activates the keyword entry field of a firmware option.

One or more keywords can be entered in the entry field. If a valid keyword is entered, *OPTION KEY OK* is displayed and the option is added to the *FIRMWARE OPTIONS* table.

If an invalid keyword is entered, *OPTION KEY INVALID* is displayed.

After installation of the option, **VSA** (= **vector signal analysis**) is displayed in the hotkey bar of the R&S FSQ/FSMR/FSU. The position of the **VSA** hotkey may vary depending on the type and number of options installed.

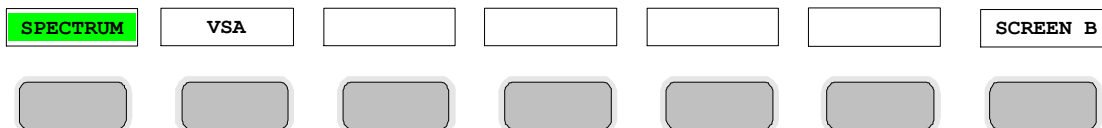

Fig. 1 Hotkey bar of basic unit with option R&S FSQ-K70/FSMR-B73/FSU-B73 installed.

Test Setup for Measurement on Base Stations and Power Amplifiers

Special precautions are to be observed when measurements on power amplifiers and mobile radio base stations are performed.

Precautions

DANGER



Danger of electric shock or from radiation

The relevant safety standards (e.g. EN 60215 and IEC215) must be complied with when operating transmitters and amplifier output stages.

Standard Test Setup

ATTENTION



Destruction of the input mixer

When transmitters or transmitter output stages with an output power of more than 30 dBm are connected, a suitable power attenuator or power coupler must be used to prevent the analyzer input stages from being damaged.

For R&S FSQ/FSMR/FSU devices with an upper frequency limit of 26.5 GHz or less, the RF input is AC-coupled with switchable AC/DC coupling. For all other R&S FSQ/FSMR/FSU devices (upper frequency limit > 26.5 GHz), the RF input is DC-coupled.

For AC-coupling, a DC input voltage of 50 V must never be exceeded. For DC-coupling, DC voltage must not be applied at the input.

In both cases, noncompliance will destroy the input mixers.

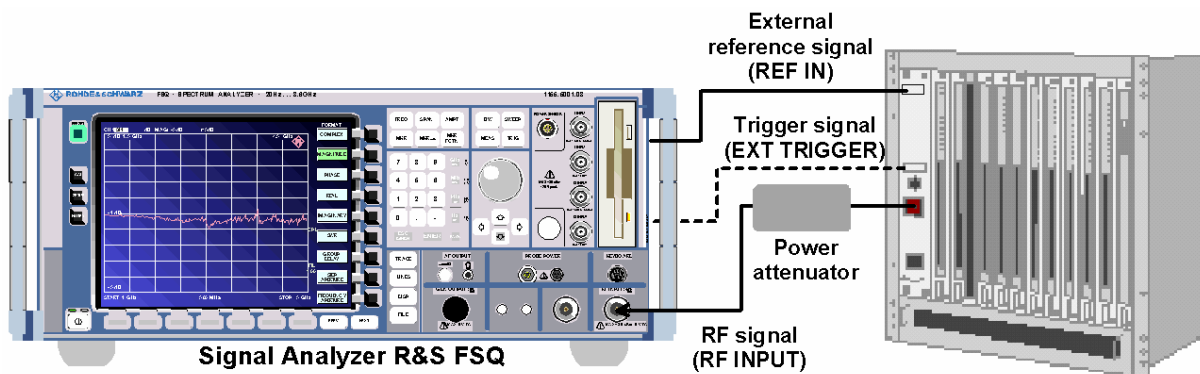
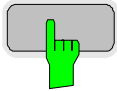

Fig. 2 Connection to RF output of a base station (for example R&S FSQ)

Calling and Exiting the Option - VSA Softkey

Calling the Option - VSA Softkey



Call the R&S FSQ-K70/FSMR-B73/FSU-B73 option by pressing the **VSA** hotkey. After activation, the labels in the hotkey bar and the contents of the menus are adapted to the functions of the VSA option. The menus of the option are described in Chapter 5, "*Instrument Settings and Measurements*".

IEC/IEEE bus command `INST:SEL DDEM`

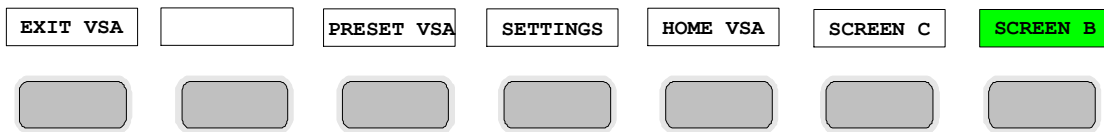
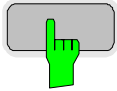

Fig. 3 Hotkey bar when option R&S FSQ-K70/FSMR-B73/FSU-B73 is active

Exiting the Option - VSA Softkey



To exit the R&S FSQ-K70/FSMR-B73/FSU-B73 option, press the **EXIT VSA** hotkey. When the option is closed, the hotkey bar and the menus of the basic unit are restored.

IEC/IEEE bus command `INST:SEL SAN`

Return to VSA Menu (Home VSA Hotkey)

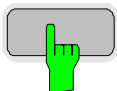
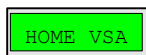

Pressing HOME VSA in any position of the VSA menu branches to the VSA menu. This function should be used particularly after frequency, level and trigger settings, because automatic return to the VSA menu is not possible in this case.

Calling and Exiting the Option - VSA Softkey R&S®FSQ-K70/FSMR-B73/FSU-B73

Overview

The following functions are shown by the diagram below:

- Starting R&S FSQ-K70/FSMR-B73/FSU-B73 in the spectrum analyzer mode
- Navigation within the application
- Exiting the application

The position of the **VSA** hotkey may vary depending on the number of activated options.

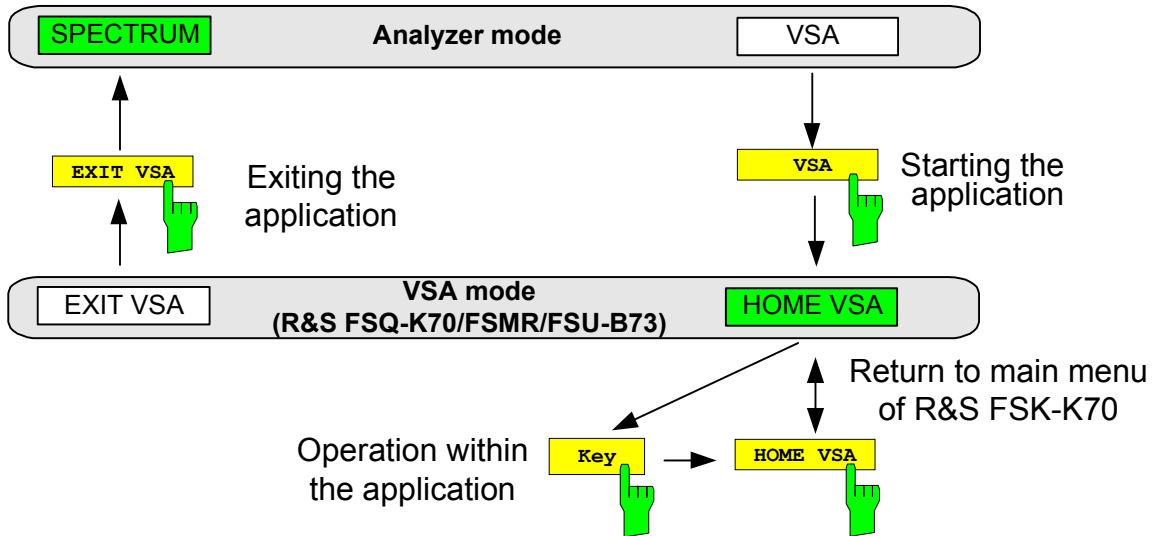

Fig. 4 Overview: calling and exiting option FSQ-K70/FSMR/FSU-B73

2 First Measurements - Getting Started

With the aid of a few sample measurements for the digital GSM and EDGE standards, this chapter gives a quick introduction to typical vector analyzer measurements. The individual measurements are in logical order and should familiarize the user gradually with the measurements required of general vector signal analysis. To benefit from this didactics, use the „Continuous – Facing“ view for the display on the screen.

The following equipment is required in addition to the Analyzer R&S FSQ/FSU/FSUP/FSG or Measuring Receiver R&S FSMR with option R&S FSQ-K70/FSMR-B73/FSU-B73:

- 1 test transmitter (GSM-compatible), preferably R&S SMIQ (1125.5555.03)
- 1 ParData Adapter R&S SMIQ-Z5 for R&S SMIQ (1104.8555.02)
- 1 RF cable with 2 male N connectors
- 2 RF cable with 2 male BNC connectors
- 2 power cables

Transmitter operation is only described as far as required for performing the measurements. For more details on the measurements, refer to the test transmitter documentation.

Interconnecting Transmitter and Analyzer

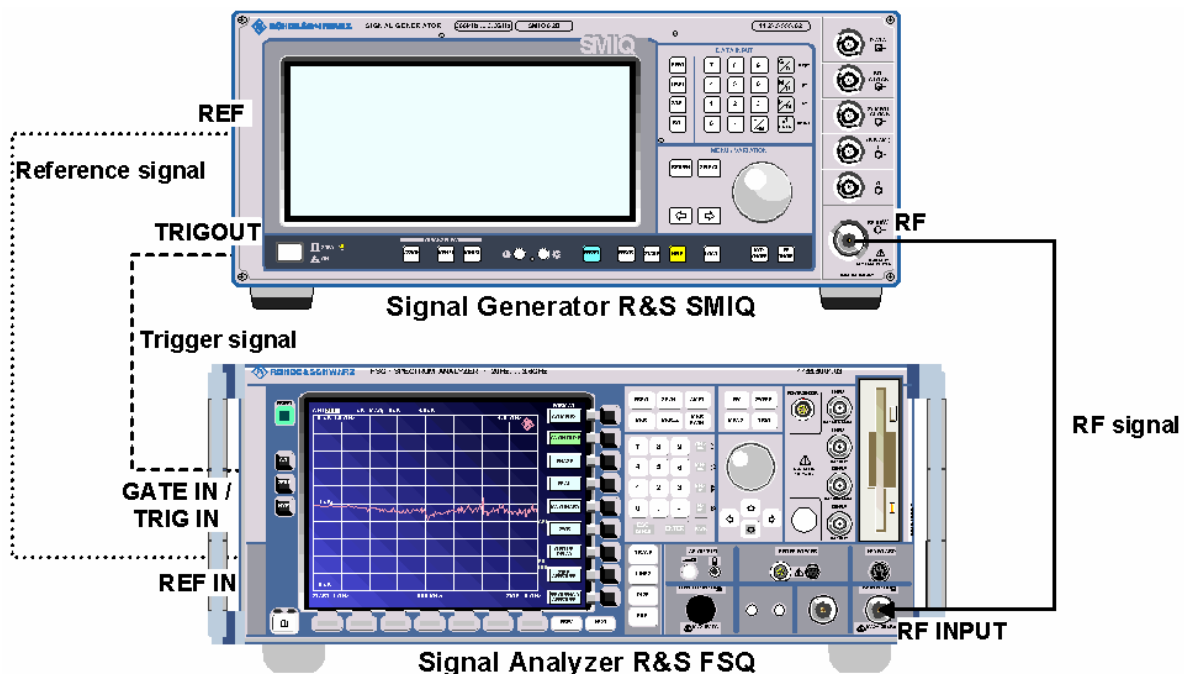

Fig. 5 Connection to a test transmitter (for example R&S FSQ)

Basic Settings of Test Transmitter

The following frequency and level settings are made on the test transmitter for the measurements below:

Table 1 Basic settings of test transmitter for first measurements

Parameter	Setting
Level	0 dBm
Frequency	2 GHz

Transmitter settings for the various measurements are listed in the table below:

Table 2 Transmitter settings for various measurements

Setting		Operating sequence SMIQ	
Basic settings for GSM / EDGE 		Digital standard GSM/EDGE State ON	<Select> <Select> <Select> <Select> <Return>
Setting	Measurement		
EDGE Single Burst	1	Save/Recall Frame Get predefined Frame EDGE0	<Select> <Select> <Select> <Return> <Return>
EDGE Full Frame	2,3,5,6,7	Save/Recall Frame Get predefined Frame EDGE_ALL	<Select> <Select> <Select> <Return> <Return>
GSM/EDGE Mixed Frame	4	Save/Recall Frame Get predefined Frame GSM_EDGE	<Select> <Select> <Select> <Return> <Return>
GSM Full Frame	4	Save/Recall Frame Get predefined Frame GSM_ALL	<Select> <Select> <Select> <Return> <Return>
EDGE Slot Att. (20 dB / slot 1..7)		Slot Attenuation 20 Select Slot Slot 1..7 Slot Level ATTEN	<Select> <dB> <Select> <mark with rotary knob> <Select> <Select> <select with rotary knob> <Select> <Return> <Return>

Switching On the R&S FSQ-K70/FSMR-B73/FSU-B73 Option

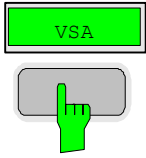

Press the **VSA** hotkey to call the R&S FSQ-K70/FSMR-B73/FSU-B73 option. After activation, the labels in the hotkey bar and the contents of the menus are adapted to the functions of the VSA option. The menus of the option are described in Chapter 5, "*Instrument Settings and Measurements*".

Basic Analyzer settings for EDGE Measurements

In the default setting after PRESET, the R&S FSQ/FSMR/FSU is in the analyzer mode. In this mode the following settings must be made:

Table 3 Basic instrument settings

Parameter	Setting
Frequency	2 GHz
Reference level	+6 dBm

The following settings of the R&S FSQ-K70/FSMR-B73/FSU-B73 option are only enabled after the vector signal analyzer mode is set and the digital standard EDGE_NB (normal burst) is selected.

Table 4 Basic setting for vector signal analysis measurements

Parameter	Setting
Digital standard	EDGE_NB
Sweep	CONTINUOUS
Burst search	ON
Pattern search	ON
Pattern	EDGE_TSC0
Display mode	Screen A: EVM Screen B: Symbols & Modulation Accuracy

Measurement 1: Demodulation of a Single EDGE Burst

Objective of the measurement:

- Demodulation of a single EDGE burst and result display
- Switchover of result display to I/Q VECTOR
- Disabling the measurement filter and measuring the raw transmitter signal

Instrument settings:

Transmitter: GSM default setting

EDGE Single Burst

Analyzer: Digital GSM standard → EDGE_NB standard
Adjust Ref Level

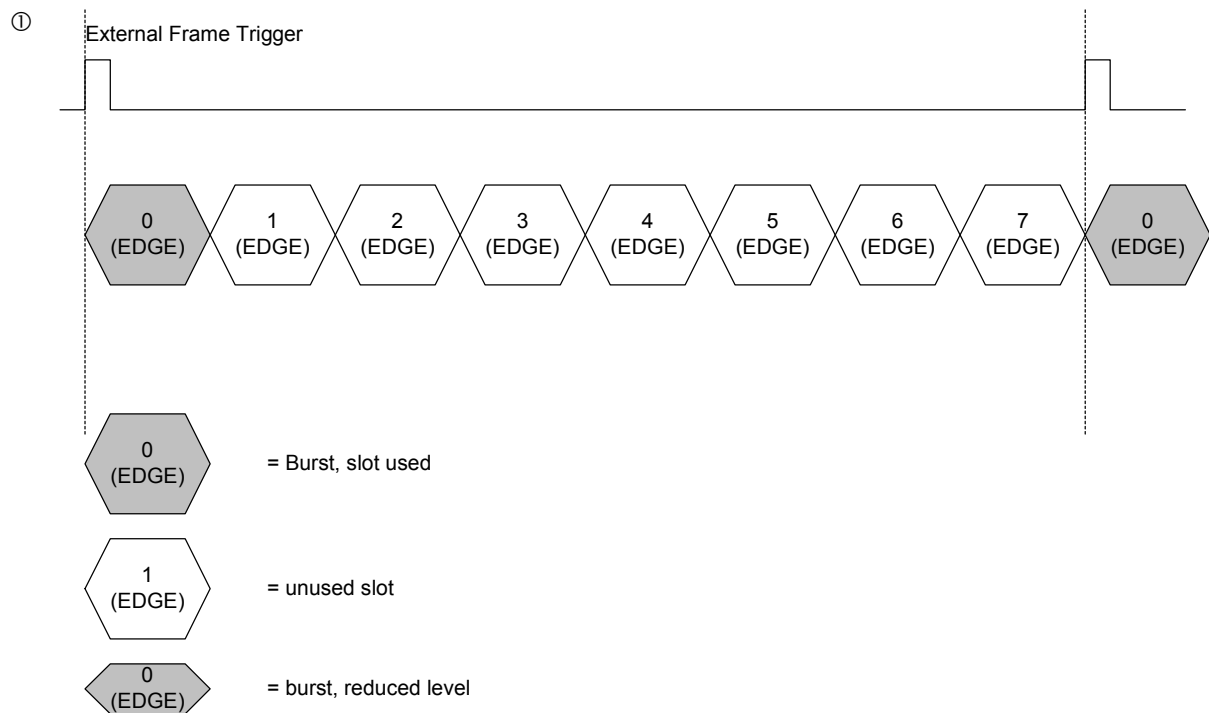

Fig. 6 Measurement 1: Frame structure

The burst numbers in the drawing correspond to the timeslots of the GSM frame structure. The transmitter settings cause a single EDGE burst in time slot 0. The time slots 1 to 7 are not assigned.

Measurement:

Fig. 7 shows a typical result display of the analyzer for the EDGE standard. In the upper half, the magnitude of the vector error is plotted over time; in the lower half numeric error values in the range of the evaluation lines are listed.

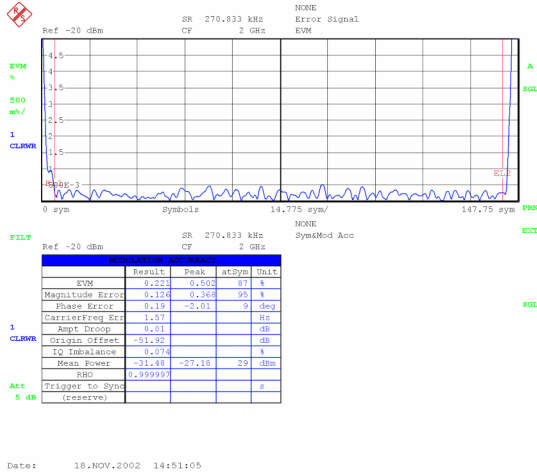

Fig. 7 Measurement 1: Result display of analyzer

For this kind of measurement with adequately set reference level and synchronization of reference oscillators between transmitter and analyzer, the following results should be displayed.

RMS EVM: <0.5%
 Center frequency error: <2 Hz

The EDGE measurement must be performed with the **measurement filter** prescribed by ETSI. If DIGITAL STANDARD EDGE is selected, this filter is automatically switched on.

With the control sequence <SCREEN A>, <MEAS RESULT>, <MEAS SIGNAL>, <I/Q VECTOR>, the associated I/Q trace is displayed (after filtering with the measurement filter, Fig. 8). With the sequence <MEAS RESULT>, <RESULT RAW>, this filter is switched off and the measurement is performed on the **raw transmitter signal** (before filtering with the measurement filter). The associated display is shown in Fig. 9.

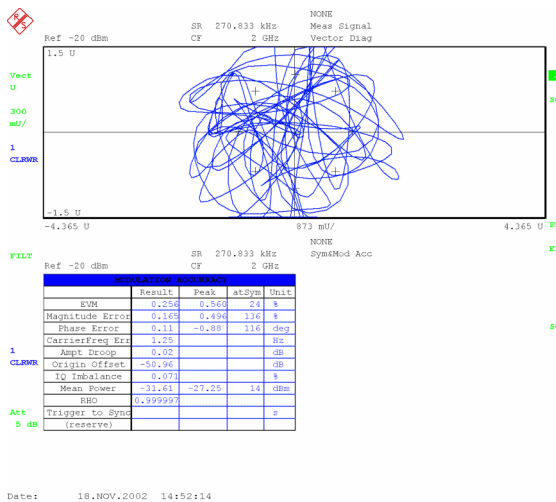

Fig. 8 Measurement 1: I/Q vector

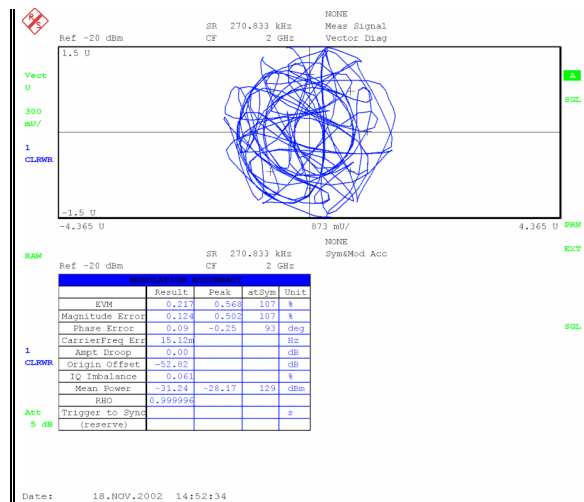

Fig. 9 Measurement 1: RESULT RAW

Switching off the measurement filter may also influence the numeric result display: high-frequency noise components that are to a great extent suppressed by the filter may cause more measurement errors.

Measurement 2: Selection of a Specific Slot with Trigger Offset

Objective of the measurement:

- Selecting a single EDGE burst by external trigger
- Changing the position of the trace in the display with FIT TRACE
- Reducing the RECORD LENGTH

Instrument settings

Transmitter: GSM default setting

EDGE Full Frame

Analyzer: Digital GSM standard → EDGE_NB standard
Adjust Ref Level

<TRIGGER OFFSET> -100 μs

<RESULT LENGTH = 200>

1) <MEAS RESULT> <MAG CAP BUFFER>

2) <MEAS RESULT> <RESULT RAW>

<MEAS RESULT> <MEAS SIGNAL> <MAGNITUDE ABSOLUTE>

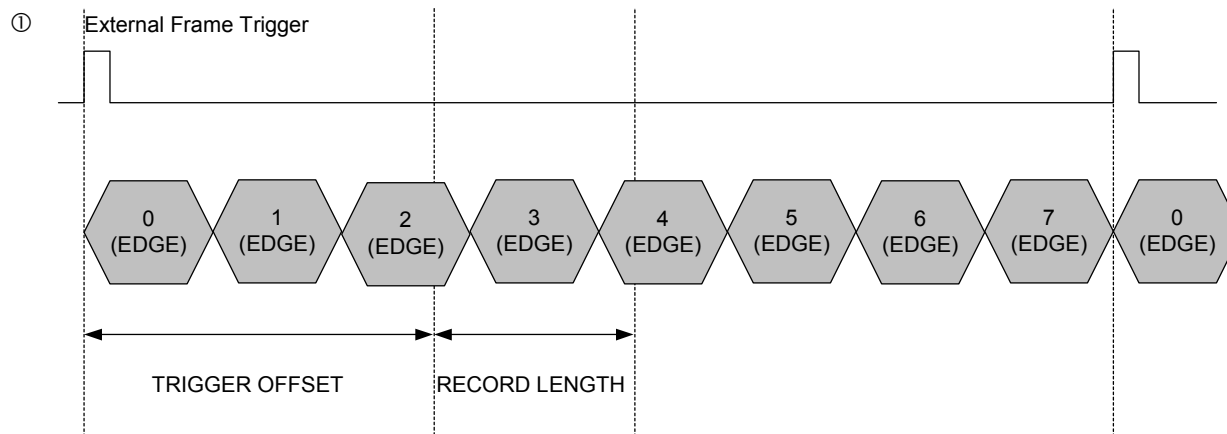

The transmitter settings cause EDGE bursts in time slots 0 to 7.

Measurement:

In the default setting, the TRIGGER OFFSET is set to -100 µs and the RECORD LENGTH to 10 times the RESULT LENGTH. The received raw signal is displayed (magnitude capture buffer, Fig. 10). With this setting the first detected pulse is demodulated. The name of the detected sync pattern that is used for synchronization is displayed (**EDGE_TSC0**, Fig. 11).

During the measurement, the TRIGGER OFFSET can be varied with the rotary knob until the **EDGE_TSC3** sync pattern is displayed. Stable demodulation is achieved with a trigger offset of +1.1 ms.

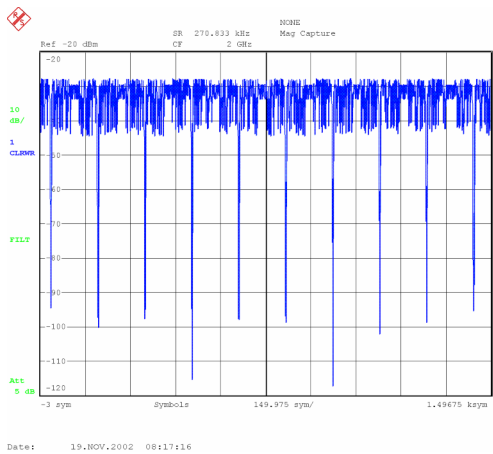

Fig. 10 Meas. 2: Magnitude capture buffer

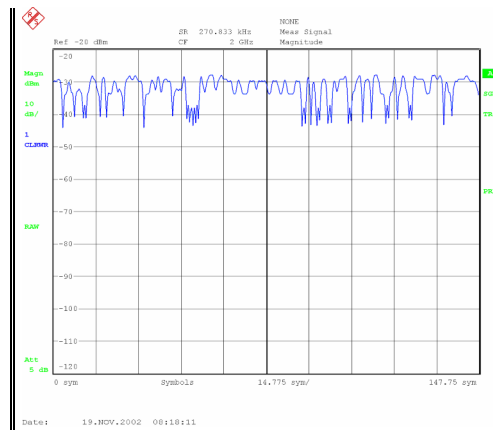

Fig. 11 Meas. 2: EDGE_TSC0

Display positioning

When GSM / EDGE is set, FIT PATTERN TO CENTER is selected for the display: the center of the detected sync pattern is represented in the center of the display.

Other possible settings are shown in the figures below:

- FIT TRIGGER TO LEFT: trigger time + trigger offset are displayed at the left screen edge
- FIT PATTERN TO LEFT: the beginning of the sync pattern is displayed at the left screen edge

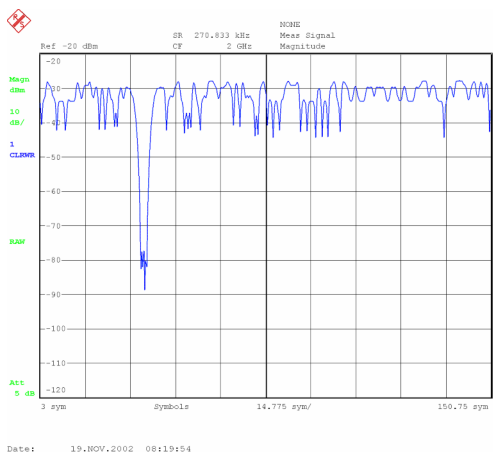

Fig. 12 Meas. 2: FIT TRIGGER TO LEFT

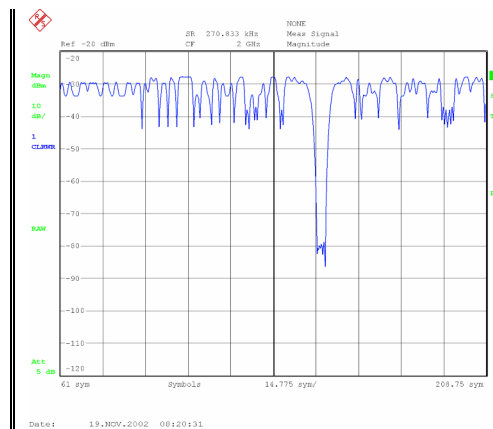

Fig. 13 Meas. 2: FIT PATTERN TO LEFT

Changing the RECORD LENGTH

To speed up the measurement, the data recording time (RECORD LENGTH) can be manually reduced (set RECORD LENGTH = 250 symbols). In some cases, display positioning with FIT TRACE and 'pattern aligned' is no longer possible.

Measurement 3: Setting the Burst Search Parameters (LEVEL)

Objective of the measurement:

- Manual setting of burst parameters
- Selective search for sync patterns

Instrument settings

Transmitter: GSM default setting
 EDGE Full Frame
 Blank slot 0 and slot 2
 Reduce level of slot 1 by 15 dB

Analyzer: Digital GSM standard → EDGE_NB standard

Adjust Ref Level

<TRIGGER> FREE RUN

<MEAS RESULT> <RESULT LENGTH = 200>

1) <DISPLAY><SPLIT SCREEN>

<DISPLAY><SCREEN B>

<MEAS RESULT> <MAG CAP BUFFER>

<DISPLAY><SCREEN A>

<MEAS RESULT> <MEAS SIGNAL> <MAGNITUDE ABS>

2) <DISPLAY><FULL SCREEN>

<MEAS RESULT> <MEAS SIGNAL> <MAGNITUDE ABS>

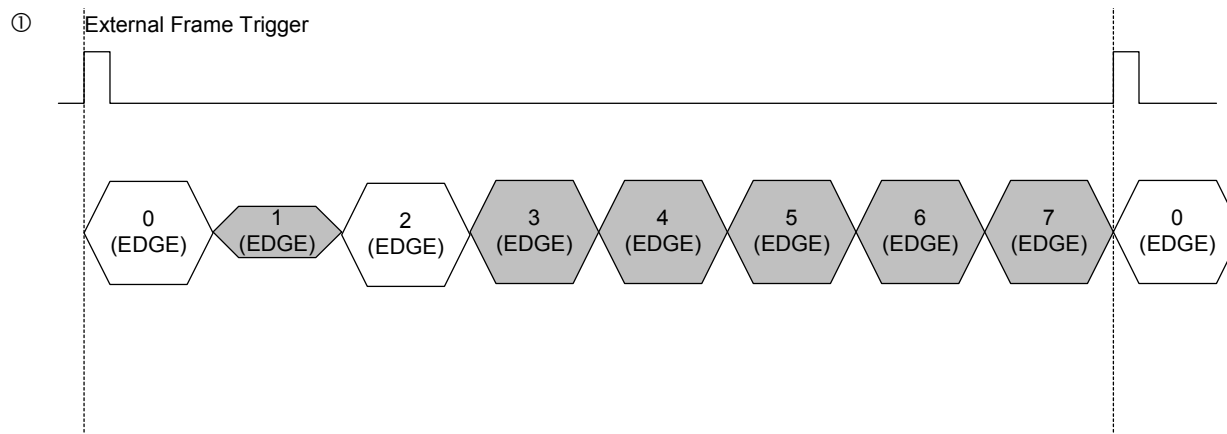

Fig. 14 Burst search parameter

This basic transmitter setting causes a single burst with reduced level in timeslot 1 and a sequence of bursts in timeslots 3 to 7.

Measurement:

In the previous measurement, a defined burst was selected for the measurement by means of an external trigger signal. If a suitable measurement signal is available, the specific burst can also be selected by manual setting of burst search parameters without external trigger.

The signal consists of a single burst of reduced level and a sequence of bursts of normal level. In automatic burst search, the level threshold depends on the maximum amplitude and slots 3 to 7 are measured. The single burst in slot 2 is not detected. Fig. 15 and Fig. 16 show different untriggered measurements in the AUTO mode.

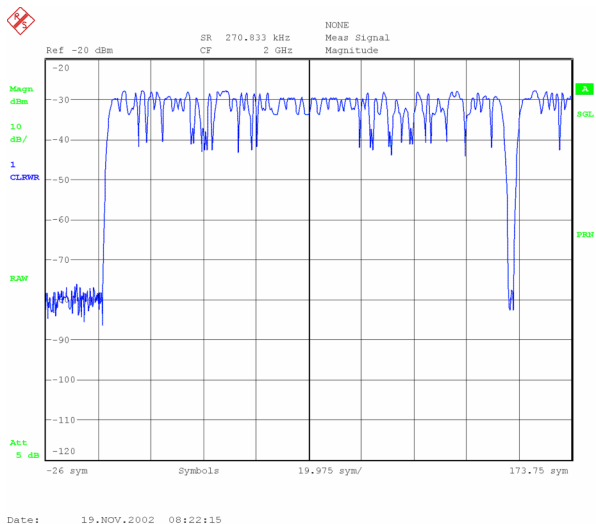

Fig. 15 Meas. 3: Burst search AUTO, EDGE_TSC4

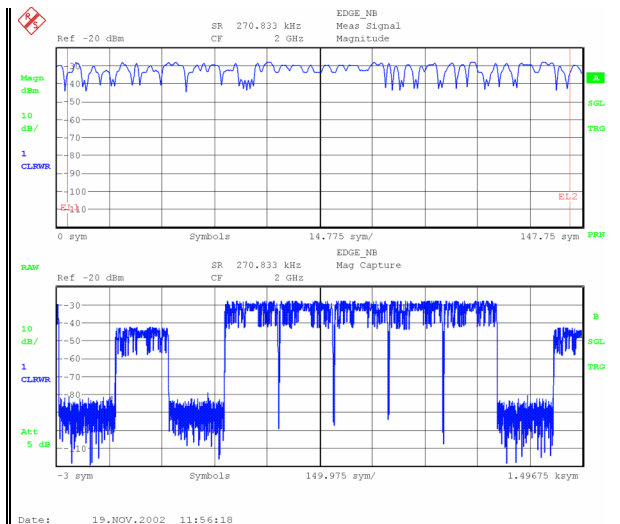

Fig. 16 Meas. 3: Burst search AUTO, EDGE_TSC3

In the next step, the burst search is set with a **level threshold of -30 dB RefLvl** (relative to reference level). Because of manual threshold setting, the level-reduced burst in slot 1 is now also detected and demodulated. Fig. 17 shows such a measurement.

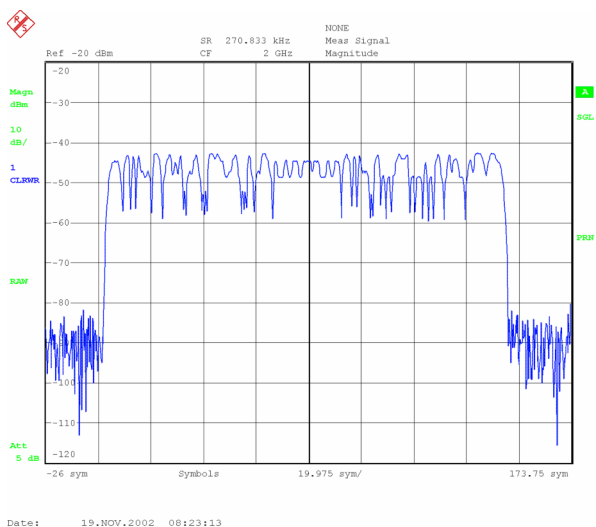

Fig. 17 Meas. 3: Burst search, manual level setting

Knowing that slot 1 contains a single burst, the settings for the burst search can be even more selective: Under **<BURST & PATTERN> <EXPERT SETTINGS>**, the **GAP LENGTH** (i.e. the gap between two consecutive bursts) is increased to 50 symbols. The search algorithm now rejects all bursts in slots 3 to 7 and only identifies the burst in slot 1 as valid because this burst is between two empty timeslots and the only one in the frame to fulfill the burst conditions (see Fig. 17).

Measurement 4: Suppression of Incorrect Measurements

Objective of the measurement:

- MEAS ONLY ON PATT operating parameter
- Similarity of GSM and EDGE patterns

Instrument settings

Transmitter: GSM default setting
 GSM Mixed Frame

Analyzer: Digital GSM standard → EDGE_NB standard

Adjust Ref Level

<DISPLAY><FULL SCREEN>

<MEAS RESULT> <MEAS SIGNAL> <MAGNITUDE ABS>

<MEAS RESULT> <RESULT RAW>

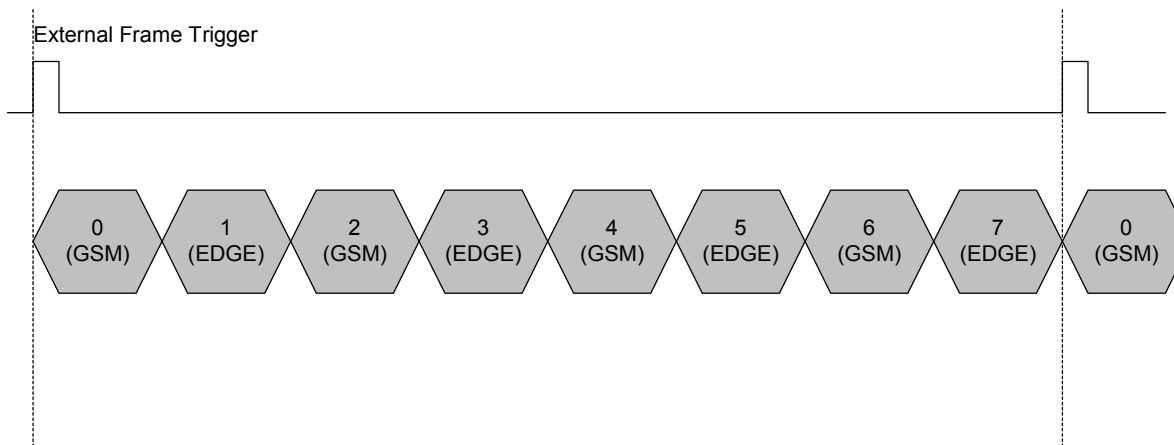

The transmitter settings cause bursts in time slots 1 to 7. GSM and EDGE bursts are transmitted alternately.

Measurement:

The signal consists of a fully used frame in which EDGE and GSM bursts are transmitted alternately. In contrast to the standard setting for EDGE_NB, the MEAS ONLY ON PATT parameter is switched off. As a result, the analyzer tries to demodulate each burst that fulfills the burst conditions. The EDGE demodulation algorithm is optimized for 3pi/8-8PSK modulation. It also synchronizes to GSM signals patterns of identical name, but a great number of error messages are issued in this case. In the case of untriggered measurements, the following result displays may be obtained.

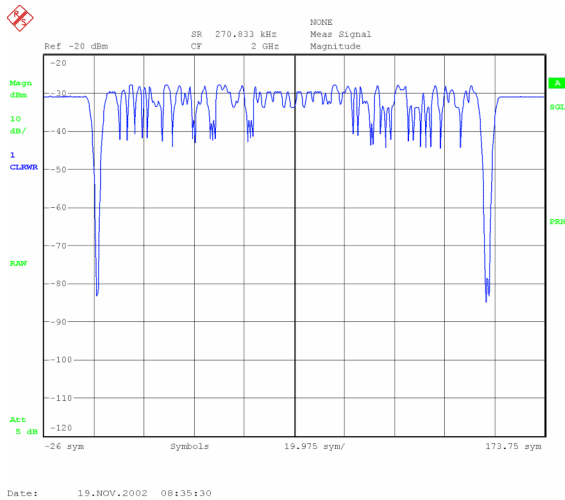

Fig. 18 Meas. 4: EDGE demodulator, correct demodulation

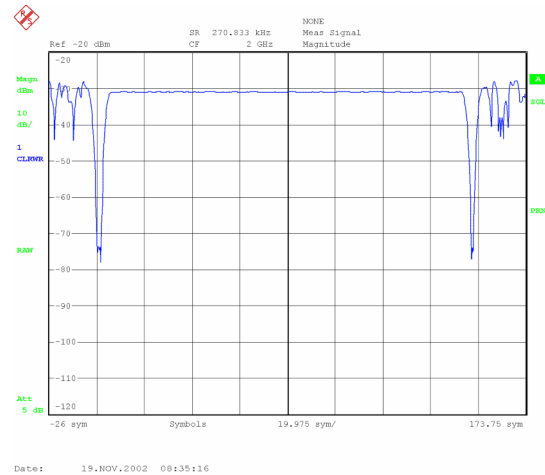

Fig. 19 Meas. 4: EDGE demodulator, incorrect demodulation of a GSM burst

The incorrect measurements can be avoided when the following settings are made:

- Select appropriate patterns for the EDGE signal (e.g. EDGE_TSC1, EDGE_TSC3, EDGE_TSC5, EDGE_TSC7)
- Activate MEAS ONLY ON PATT softkeys

The display is only updated after a valid measurement. After a faulty measurement the display remains unchanged and the SEARCHING PATTERN message is displayed.

Despite the similarity of the GSM and EDGE sync patterns, the GSM demodulator is not able to identify EDGE patterns. To suppress invalid measurements (pattern not found), the MEAS ONLY ON PATT softkey must also be activated.

Measurement 5: Evaluation Lines

Objective of the measurement:

- Use of evaluation lines for determining result ranges

Instrument settings

Transmitter: GSM default setting
 GSM Full Frame

Analyzer: Digital GSM standard → GSM_NB standard

<Adjust Ref Level>

<DISPLAY> <SPLIT SCREEN>

1) <SCREEN A> <MEAS RESULT> <MAGNITUDE ABS>

<SCREEN B> <MEAS RESULT> <SYM & MODUL ERR>

2) <SCREEN B> <MEAS RESULT> <MAGNITUDE ABS><SIGNAL STATISTIC>

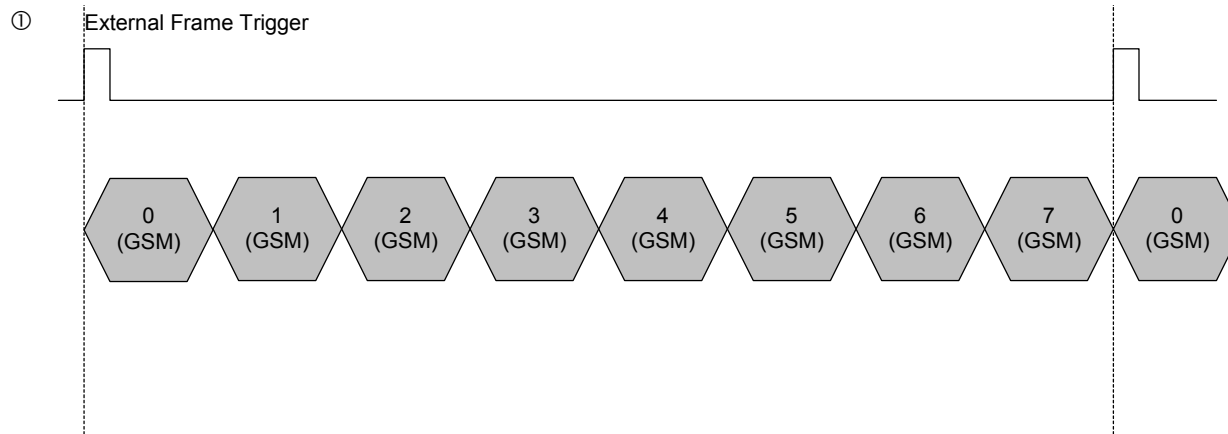

The transmitter settings cause GSM bursts in time slots 0 to 7.

Measurement:

Evaluation lines delimit the range in which numeric results such as EVM, phase error, magnitude error, RHO are determined. The range is preset and automatically considered when a digital standard is set. In the first figure below, the EVAL LINES are correctly set; in the second, they are set on the burst edge.

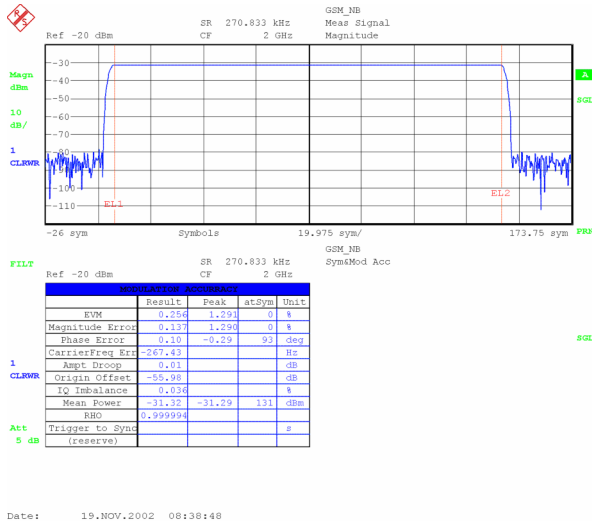

Fig. 20 Meas. 5: Setting the evaluation range: presetting the standard

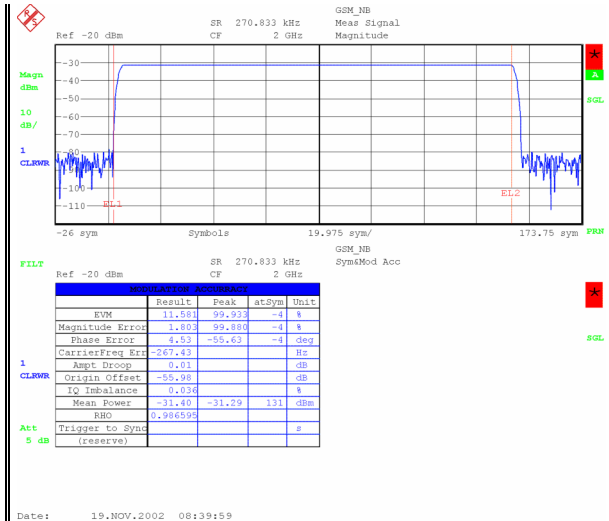

Fig. 21 Meas. 5: Setting the evaluation range: extension to burst edges

The evaluation lines also affect derived displays such as statistical signal evaluation. Fig. 22 shows the statistical level distribution within the burst. In Fig. 23, the EVAL LINES are extended to ranges outside the burst which is reflected by the level's probability of occurrence.

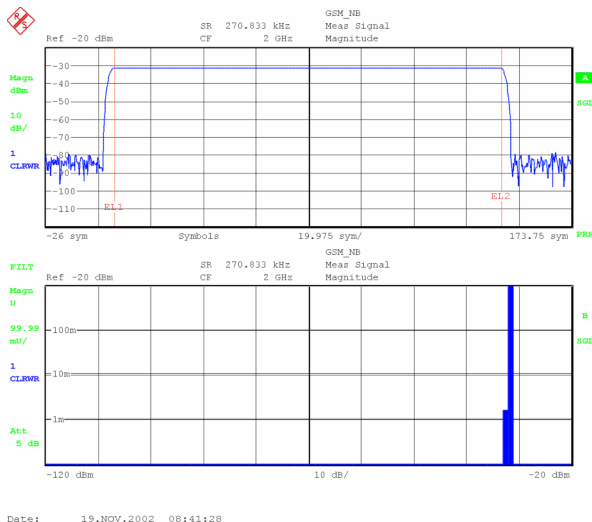

Fig. 22 Meas. 5: Level distribution within the burst

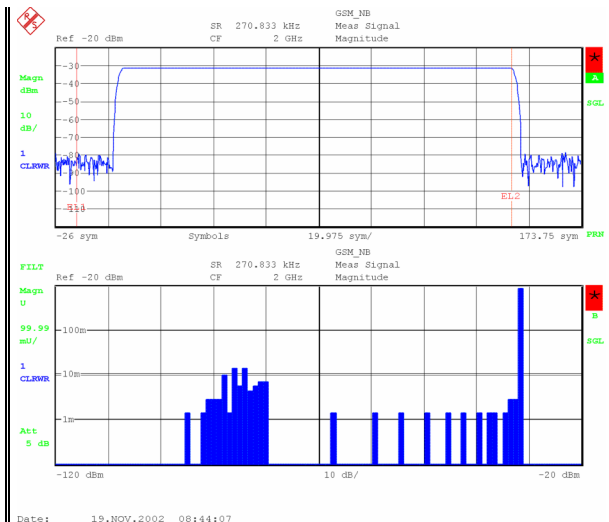

Fig. 23 Meas. 5: Level distribution within and outside the burst

The displayed measurements were performed in the SINGLE SWEEP mode. The display at the right was obtained solely by varying the EVAL LINE 1 without receiving new data. For this reason the measurement is marked with a red asterisk *. Parameters relating to this measurement (e.g. modulation errors or statistics diagrams) are recalculated, however.

3 Brief Description of Vector Signal Analysis (Function)

The "Vector Signal Analysis" software option R&S FSQ-K70/FSMR-B73/FSU-B73 performs vector measurements for analyzing modulation errors of RF signals converted to the complex baseband. Carrier envelope and time domain measurements can also be performed but these measurements can be carried out in the basic unit (frequency analyzer) with a considerably wider bandwidth. The same applies to spectral measurements such as adjacent-channel power measurements on mobile radio signals.

The following sections describe the digital signal processing hardware, the interplay of analog and digital filters for bandwidth limiting, system-theoretical modulation and demodulation filters as well as the algorithms used by the measurement demodulator. The implemented modulation modes and the associated predefined symbol mappings are also listed.

The last part of this chapter deals with vector and scalar modulation errors. The required calculation formulae are provided in the Annex to this manual.

Block Diagram of Digital Signal Processing Hardware

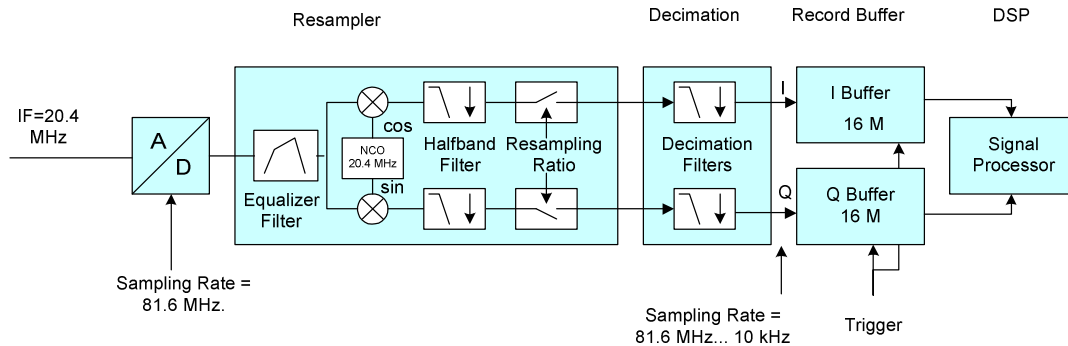

Fig. 24 Block diagram of digital hardware for vector signal analysis

Description of Block Diagram

After having passed several RF, IF and filter stages, the RF input signal is converted to an IF of 20.4 MHz and applied to an A/D converter with a sampling frequency of exactly 81.6 MHz.

The digitized signal is then routed through two ICs for resampling (conversion of sampling rate by a real factor) and for filtering and decimation (reduction of sampling rate by an integral factor). An EQUALIZER FILTER is connected to the RESAMPLER input to compensate for the frequency response of the analog filter stages which would otherwise add to the modulation errors.

During operation, the filters and decimation factors of the instrument are set so that a sampling frequency is obtained at the output of the DECIMATION stage, which exactly corresponds to the following equation:

$$\text{Sampling rate} = \text{Symbol rate} * \text{Points/symbol } \{4, 8, \text{ or } 16\};$$

A higher point/symbol setting automatically results in a corresponding increase of the I/Q bandwidth. The resulting measurement bandwidths are described in the sections below.

The complex output signal of the DECIMATION stage is stored in the I/Q memory (RECORD BUFFER) and forwarded to a signal processor (DSP) for further processing.

The data recording length and the result length after DSP processing are limited to about 32k samples (irrespective of the set symbol rate or sampling rate).

The received baseband signal is filtered in the subsequent DSP stage as required by the signal, then demodulated **without the transmitted data being known** (non-data-aided demodulator) and scanned for sync patterns. An ideal transmit signal is reconstructed from the demodulated data, and various modulation and vector errors, which are described in the following sections, are obtained from a comparison of demodulated and ideal I/Q signals.

In addition to setting the modulation mode, **ACCURATE** setting of **symbol rate** and **filter parameters** is important for a correct demodulation. Even slight deviations may noticeably impair the measurement result.

Examples are given in the Troubleshooting section.

Supplement to the R&S FSQ-B72 Option

The R&S FSQ-B72 option additionally allows sampling rates from >81.6 MHz to 326.4 MHz. With sampling rates ≤81.6 MHz, the R&S FSQ-B72 option is not active. The analyzer then behaves in the way described above. Fig. 25 shows the hardware of the analyzer from IF up to the processor for sampling rates above 81.6 MHz. An IF filter of 120 MHz is effective. The A/D converter samples the IF (408 MHz) at a rate of 326.4 MHz. The points/symbol setting parameter is fixed at {4}.

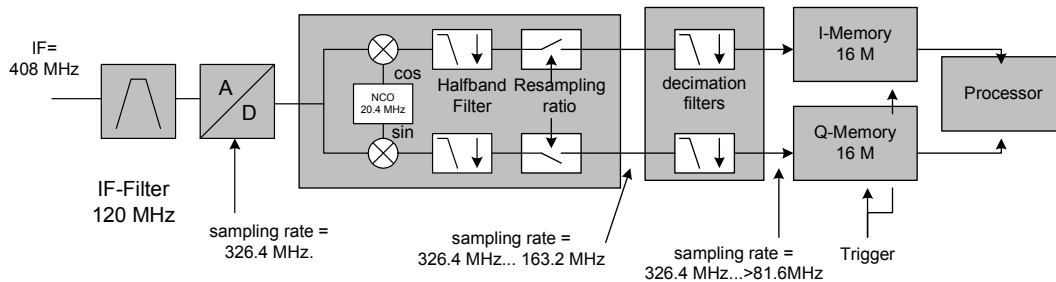

Fig. 25 Block diagram with the signal processing of the R&S FSQ at sampling rates >81.6 MHz.

Bandwidths for Signal Processing

Relevant filters for vector signal analysis are shown in the block diagram below.

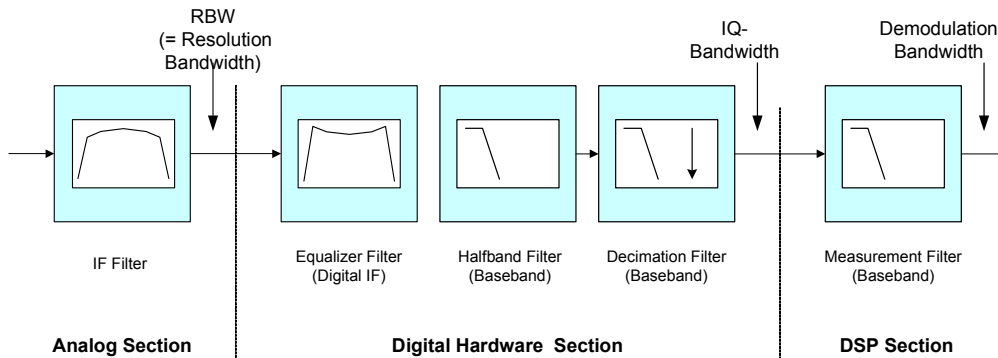

Fig. 26 Block diagram of bandwidth-relevant filters for vector signal analysis

The total bandwidth is obtained when the shown filter stages are series-connected:

- IF filter (RBW) with selectable nominal bandwidths 120 MHz^{*)} 50 MHz^{**)}, 20 MHz^{**)}, 10 MHz, 5 MHz, 3 MHz, 1 MHz and 300 kHz
- Digital hardware filter (in RESAMPLER and DECIMATION blocks)
- Measurement filter (MEAS FILTER) in the signal processor

Digital filters in the **digital hardware section**:

- Equalizer filter for compensating amplitude and phase distortions of RBW filters
- Halfband filter for limiting the bandwidth to approx. 40 MHz or 160 MHz (if R&S FSQ-B72 is active)
- Decimation filter for limiting the bandwidth to 0.8 times the output sampling rate. Note: In case of very high sampling rates, this filter is bypassed.

In the **DSP section**, the demodulation bandwidth can be further reduced by a measurement filter. If this filter is not required for the measurement, measurements are performed with the I/Q bandwidth.

^{*)} only if R&S FSQ-B72 is active; fixed at 120 MHz

^{**)} available for R&S FSQ and R&S FSMR only

Equalizer filter and halfband filter are only of minor importance for the total bandwidth. The other filters and the filters required for intersymbol-interference-free (ISI-free) demodulation are described in detail in the sections below.

Analog RBW Filters

The spectrum of the receive signal is reduced by means of analog prefilters so that the IF stages of the analyzer are optimally driven by the desired signal and undesired mixer products are reduced. To obtain optimum characteristics for vector signal analysis, the amplitude and phase frequency response within the demodulation bandwidth should be as flat as possible. The permissible IF filters are listed in the table below.

Filter bandwidths ≥ 3 MHz are equalized by means of a built-in calibration procedure and can be used for up to 2/3 of the nominal bandwidth (unless stated otherwise in the table). The maximum equalized IF signal bandwidth that can be used is limited to 28 MHz or 120 MHz (if R&S FSQ-B72 is active).

Filter bandwidths < 3 MHz are not equalized and can be used for vector signal analysis up to approx. 1/10 of the nominal bandwidth without noticeably affecting the modulation error. Using the bandwidth above this limit considerably reduces the measurement accuracy.

Unless special measures are required for interference suppression, we recommend using the RBW = AUTO setting.

With **RBW = AUTO**, the analog RBW filter is set by the analyzer so that the "bandwidth used" (see table below) is wider or equal to the bandwidth of the subsequent digital filter stages.

With **RBW = MANUAL**, the filter bandwidth specified in the table below may be reduced. If a **usable filter bandwidth** below the Symbol rate * Points/symbol bandwidth is selected, UNCAL is displayed.

Table 5 RBW filter bandwidths and usable bandwidths

RBW operating parameter	Digitally compensated	Usable bandwidth (effect on filter negligible)	UNCAL display if usable bandwidth is <
300 kHz	N	1/10*300 kHz = 30 kHz	Symbol rate * Points/symbol
500 kHz	N	1/10*500 kHz = 50 kHz	Symbol rate * Points/symbol
1 MHz	N	1/10*1000 kHz = 100 kHz	Symbol rate * Points/symbol
3 MHz	Y	2 MHz	Symbol rate * Points/symbol
5 MHz	Y	3 MHz	Symbol rate * Points/symbol
10 MHz	Y	7 MHz	Symbol rate * Points/symbol
20 MHz ¹⁾	Y	17 MHz	Symbol rate * Points/symbol
50 MHz ¹⁾	Y	28 MHz	-
120 MHz ²⁾	Y	120 MHz	-

¹⁾ available for R&S FSQ and R&S FSMR only

²⁾ only if R&S FSQ-B72 active; other bandwidths cannot be set

I/Q Bandwidth

Table 6 specifies the I/Q bandwidth that can be achieved as a function of the sampling rate.

For sampling rates between 40.8 MHz and 81.6 MHz, the bandwidth is limited to approx. 40 MHz by the halfband filter but the RBW of the preceding IF filter (max. 28 MHz, R&S FSU max. 10 MHz) is decisive for the total bandwidth. A decimation filter is not active with this setting.

For lower sampling rates, the bandwidth of the decimation filter is decisive provided no narrower (equalized) RBW is set.

Sampling rates between 81.6 MHz and 100 MHz are achieved by sampling at a fixed rate of 81.6 MHz followed by interpolation. Although a decimation filter is activated again in this mode, the RBW of the IF filter is the determining factor for the total bandwidth.

If the R&S FSQ-B72 option is activated, an RBW of 120 MHz, a halfband filter of 160 MHz, as well as a bandwidth of the decimation filter of $0.68 * F_symbol/2$ is always active.

Table 6 Maximum I/Q bandwidths of data recording

Sampling rate f_{sample} [MHz]	RBW bandwidth	Equivalent IF BW (halfband filter)	Equivalent IF BW (decimation filter)
81.6...326.4 MHz*)	120 MHz	ca. 160 MHz	$0.68 * f_{sample}$
81.6 to 100 (interpolation)	Equalized RBW, max. 28 MHz**)	approx. 40 MHz	$0.35 * f_{sample}$
40.8 to 81.6	Equalized RBW, max. 28 MHz**)	approx. 40 MHz	-
20.4 to 40.8	Equalized RBW, max. 28 MHz**)	approx. 40 MHz	$0.68 * f_{sample}$
< 20.4	Equalized RBW, max. 28 MHz**)	approx. 40 MHz	$0.8 * f_{sample}$

*) only if R&S FSQ-B72 active

**) for R&S FSU max. 7 MHz

The table below shows the effect of the symbol rate and of points/symbol parameters on the sampling rate.

Table 7 I/Q bandwidth as a function of POINTS/SYM setting

Parameter POINTS / SYM	I/Q baseband BW (single side)	I/Q IF BW (double side)	Example: I/Q IF BW ($f_{symbol} = 100$ kHz)
1, 2, 4	$(0.8 * f_{symbol}/2) * 4$	$(0.8 * f_{symbol}/2) * 4 * 2$	360 kHz
4*) (fest eingestellt)	$(0.68 * F_symbol/2) * 4$	$(0.68 * F_symbol/2) * 4 * 2$	-
8	$(0.8 * f_{symbol}/2) * 8$	$(0.8 * f_{symbol}/2) * 8 * 2$	720 kHz
16	$(0.8 * f_{symbol}/2) * 16$	$(0.8 * f_{symbol}/2) * 16 * 2$	1440 kHz

*) only if R&S FSQ-B72 is active

For common **PSK**, **QAM** and **MSK** systems, signal sampling with 4 points/symbol fulfills the system-theoretical requirements for a measurement demodulation.

A higher oversampling rate yields a better resolution of displayed traces but it may cause more measurement errors if the extended I/Q bandwidth contains interferences (and the measurement bandwidth corresponds to the I/Q bandwidth). An example is given in the following section.

With **FSK** systems, oversampling must be set to match the modulation index so that no modulation errors are produced by I/Q filtering.

Demodulation Bandwidth (Measurement Bandwidth)

The demodulation bandwidth is the part of the spectrum used for demodulation and measurement of the digitally modulated signal. In most cases, the spectrum is routed through a receive filter to obtain intersymbol-interference-free conditions permitting optimum symbol decision. After this receive filter, the modulation error is also measured. For this reason the term MEASUREMENT FILTER (Meas_Filter) is used here. A few modulation systems, especially MSK and FSK, do not use this input filtering. In these cases special care should be taken that no interference or adjacent channels occur within the demodulation bandwidth.

The figure below shows the demodulation bandwidths with different settings of the oversampling rate.

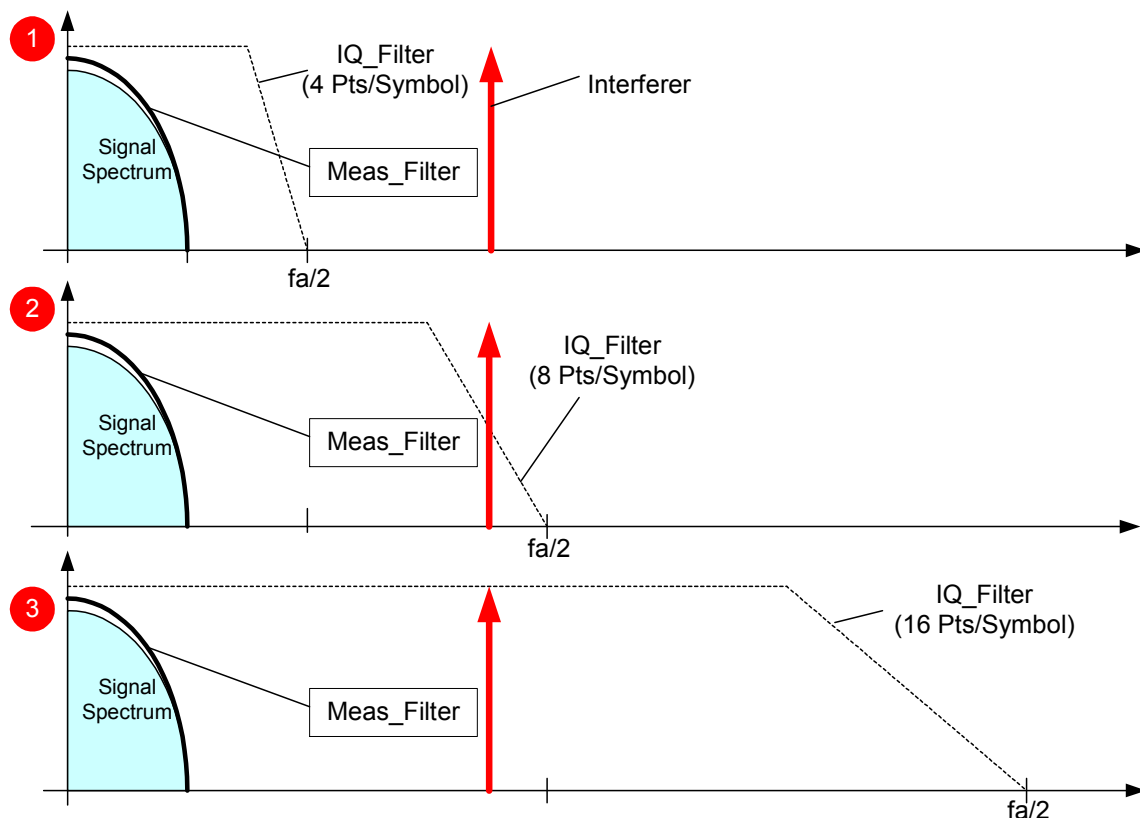

Fig. 27 Selected oversampling rates (I/Q bandwidth, interference)

Fig. 27 shows the spectrum of a digitally modulated signal that was sampled with the oversampling rates 4 (1), 8 (2) and 16 (3).

In addition to the signal spectrum - which is identical in all three cases - different I/Q bandwidths and a single-frequency interfering signal are shown.

If a demodulation or measurement filter is used, the interferer is suppressed in all three examples and the measurement bandwidth corresponds to that of the measurement filter.

If no filter is used for the measurement, the interfering carrier is suppressed by the I/Q filter only in example 1; in example 2 it is partly suppressed and in example 3 not at all.

The same effect occurs if the measurement filter is switched off for special measurements on unfiltered PSK and QAM signals (RESULT = RAW setting).

Typical PSK systems prescribe special receive or measurement filters (e.g. root-raised cosine receive filter or EDGE measurement filter).
If no such filtering is performed, care should be taken that neither interfering signals nor adjacent channels fall within the demodulation bandwidth.

System-Theoretical Modulation and Demodulation Filters

Sampling points are required for demodulation in the analyzer, where only information of the current symbol and none of neighbouring symbols is present (symbol points). These points are also called ISI-free points (ISI = intersymbol interference). If the transmitter does not provide an ISI-free signal after the transmit filter, this condition can be fulfilled by signal-specific filtering of the analyzer input signal (ISI filter). If an RRC (root-raised cosine) filter is used in the transmitter, an RRC filter is also required in the analyzer to obtain ISI-free points.

In many PSK systems, RRC filters are used as transmit, ISI and measurement filters. To determine the I/Q measurement error, the measurement signal must be compared with the I/Q trace of an ideal signal. For this purpose a REFERENCE FILTER is required which is calculated by the analyzer from the coefficient convolution of the transmit filter (TX FILTER) and the MEAS FILTER (see Fig. 28 RESULT = FILT).

If unfiltered signals have to be measured as well (e.g. to determine nonlinear signal distortions), no measurement filter is switched into the signal path and the REFERENCE FILTER is identical with the Tx filter (see Fig. 29, RESULT = RAW).

In the baseband block diagrams below, the system-theoretical transmitter and analyzer filters are shown for PSK, QAM and VSB demodulation. For the sake of clearness, RF stages, RBW filters and the filter stages of the digital hardware section are not shown.

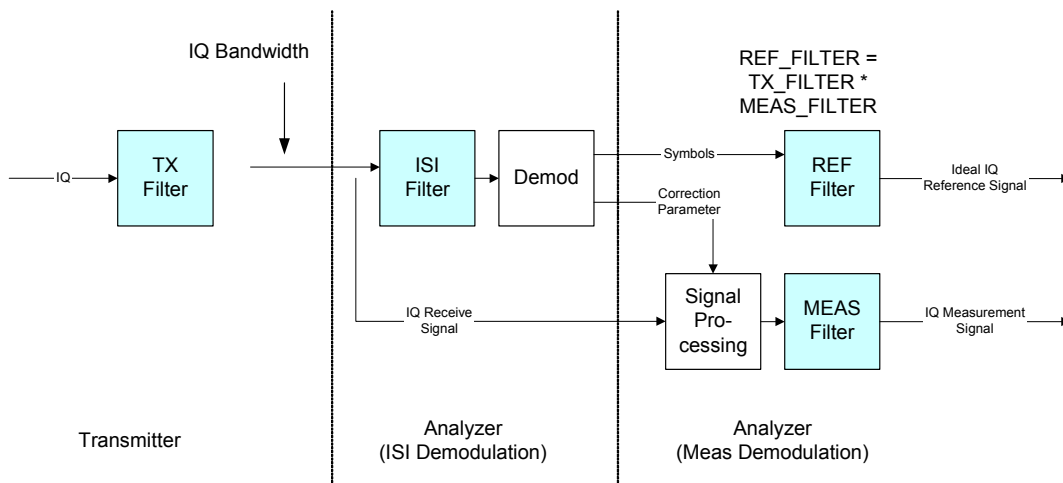

Fig. 28 Block diagram of filters in the PSK mode (RESULT = FILT setting)

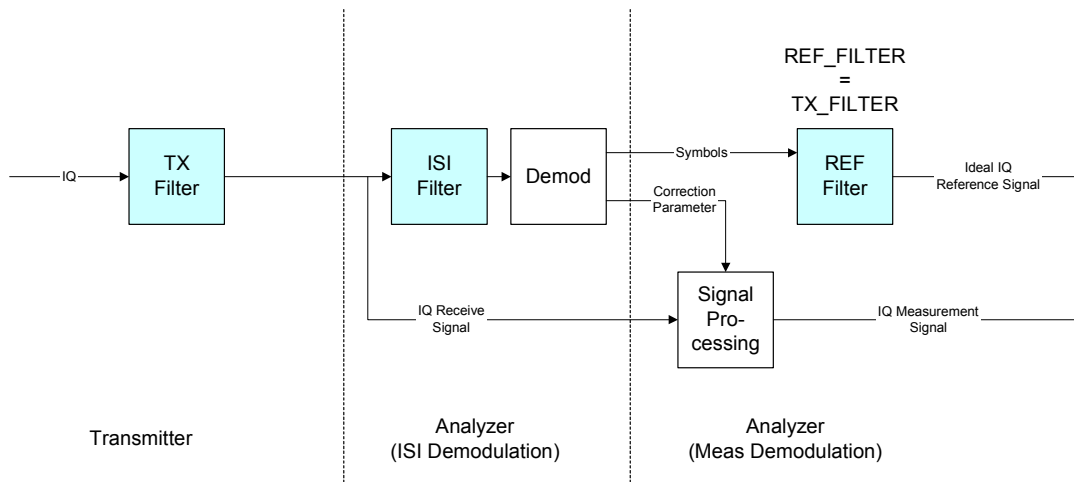

Fig. 29 Block diagram of filters in the PSK mode (RESULT = RAW setting)

For a correct demodulation, 3 filters have to be accurately specified for the analyzer:

- **transmit filter (TX filter):** filter characteristic of transmitter
- **receive filter (ISI filter):** filter characteristic of a receive filter producing intersymbol-interference-free points from the Tx-filtered signal
- **MEAS filter:** filter used for measurements. In many applications, this filter is identical with the ISI filter.

The

- **REFERENCE filter** synthesizes the ideal transmit signal (after MEAS filtering). It is calculated by the analyzer from the above filters (convolution operation TX_FILTER * MEAS_FILTER).

Table 8 Typical combinations of TX, ISI and MEAS filters

Mod. type	Modulation filter (transmit filter)	Demodulation filter = receive filter (analyzer)	Measurement filter (analyzer)	Remarks
PSK, QAM, VSB	RC (raised cosine)	-	-	ISI system
PSK, QAM, VSB	RRC (root raised cosine)	RRC	RRC	ISI system
FSK	Gauss	-	-	Near ISI system
MSK	Gauss	-	-	Near ISI system
EDGE	Gauss linearized	EDGE_ISI	EDGE_MEAS	Standard-specific filters, NO ISI system!
Cdma_2k	CDMA2k 1X TX	CDMA2k_1X_ISI	CDMA2k_1X_ISI	Standard-specific filters, but ISI system.

Typical combinations of TX, ISI and MEAS filters are shown in the table above; they can be set in the analyzer as a FILTER SET. If RC (raised cosine), RRC (root-raised cosine) and GAUSSIAN filters are used, the ALFA (RC, RRC filters) and BT (GAUSSIAN filters) parameters must be set in addition to the filter characteristic (roll-off factor).

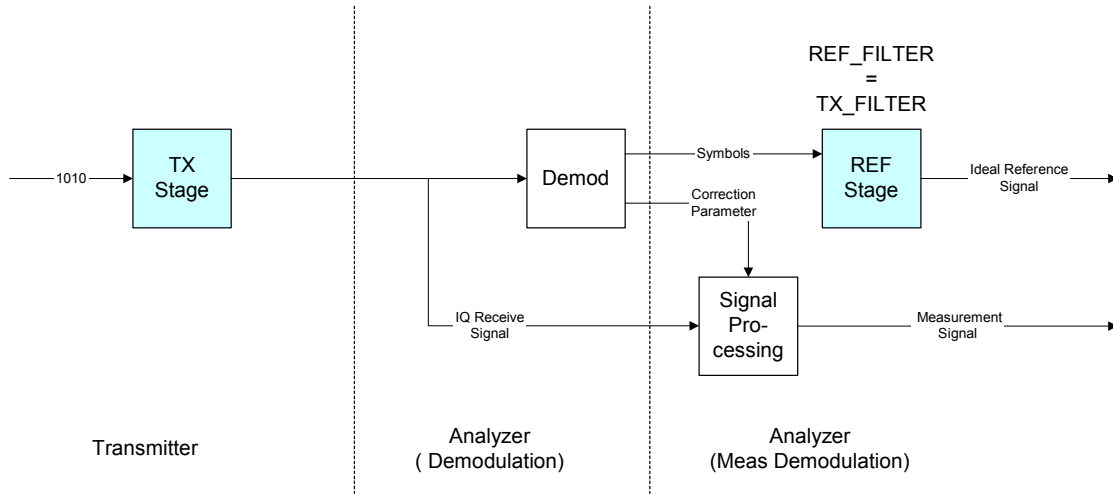

Fig. 30 Block diagram of filter stages in the MSK and FSK modes

No further band limiting is performed in FSK and MSK systems by MEAS or ISI filters in the signal path. Some parts of signal generation in the transmitter and generation of the reference signal in the analyzer are much more involved. The next section contains detailed block diagrams for signal generation and describes requirements caused by customized filters in the instrument.

Design and Use of Customized Filters

The analytical filter types RC (raised cosine), RRC (root-raised cosine) and GAUSSIAN as well as the most important standard-specific filters are already integrated in the basic unit. The requirements described in this chapter should be observed when customized filters are designed.

Customized filters may be useful for the following purposes:

- Development of new networks and modulation methods for which no filters are defined yet.
- Measurements of transmitter characteristics with slightly modified (e.g. shortened) transmitter filters.

Filter for PSK, QAM, USER-QAM and VSB

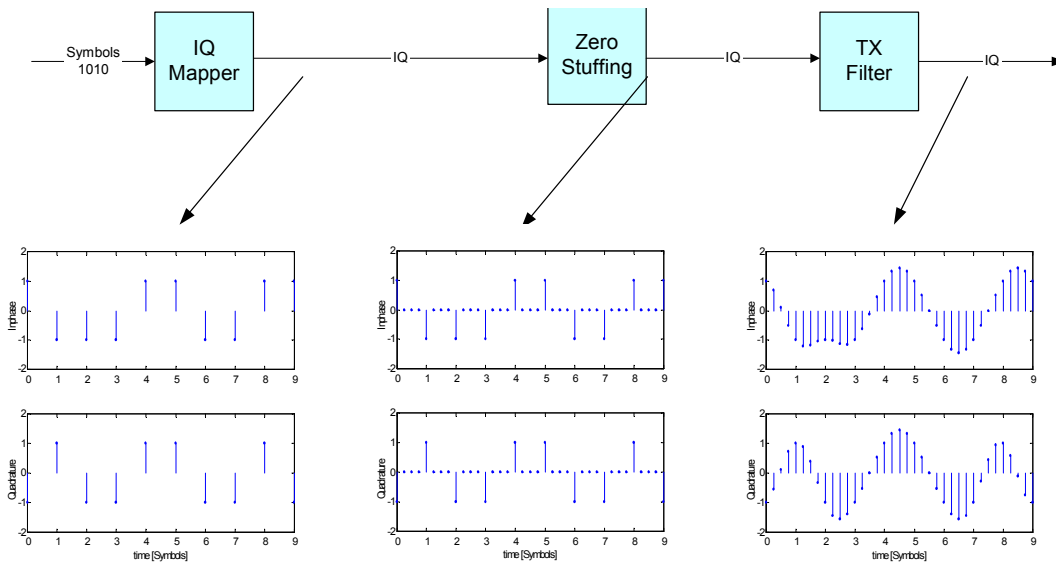

Fig. 31 Generation of baseband transmit signal (PSK, QAM, USER-QAM and VSB)

Fig. 31 illustrates generation of a QPSK signal in the complex baseband. In an I/Q mapper, logic symbols are mapped onto complex symbols in the I/Q plane. In the ZERO STUFFING stage, zeros are inserted between the symbols, and this oversampled signal is then filtered in the TX filter stage. For the sake of clearness, the signals in the figures are oversampled with 4 points/symbol.

Filter for FSK / MSK

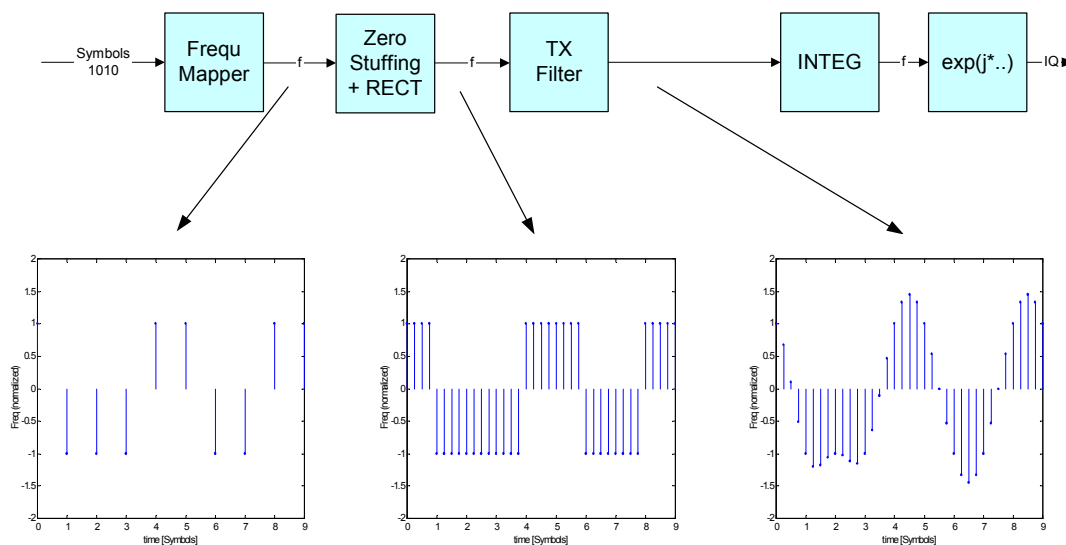

Fig. 32 Generation of transmit signals (FSK, MSK)

Fig. 32 illustrates the generation of a 2-level FSK signal.

An I/Q mapper maps logic symbols onto real Dirac pulses in the frequency-versus-time plane. In the ZERO STUFFING + RECT stage, each Dirac pulse is replaced by a square pulse of one symbol length. This oversampled signal is then filtered in the TX filter stage.

The INTEGRATOR and EXP stages have nothing to do with filtering; they only convert the signal to the I/Q plane. As in the previous example, the signals are oversampled by the factor 4.

The following requirement must be met by all customized filters:

- Oversampling rate ($f_{\text{sample}} / f_{\text{symbol}}$) of 32 in the time domain
- The filter must feature purely real coefficients
- The number of coefficients must be uneven
- The filter must be symmetrical to the central filter coefficient.

Adaptive Equalizer Filter

A possible source of high modulation errors of the DUT with PSK and QAM signals is a non-flat frequency response or ripple in frequency response within the modulation bandwidth.

This could be caused by the DUT's

- Analog filter sections
- Digital filter sections, if a shortened filter length is used
- Digital arithmetic sections, if a shortened bit-length is used

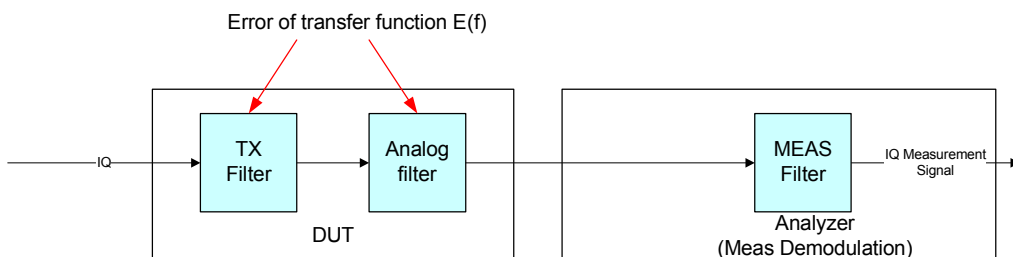

Fig. 33 Base band schematic of the modulation- and demodulation stages

In the case of low linear distortions an equalizer filter (with reverse frequency response characteristic) is able to compensate the distorted frequency response in order to improve the modulation analysis results (see figure below).

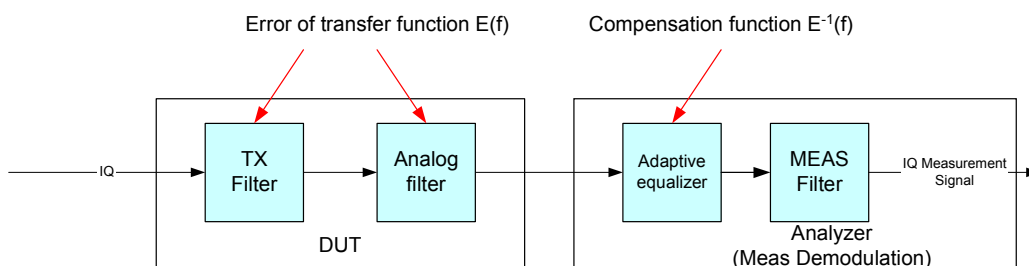

Fig. 34 Base band schematic: compensation of the transfer function's error by inserting an adaptive equalizer in the receive path

The measurement demodulator's signal path -including the adaptive equalizer filter- is shown in figure zz. In front of the demodulation chain the adaptive filter is arranged. The filter coefficients are adapted in such a way that the mean square value of the error vector magnitude (EVM) is minimized. By comparing the demodulated measuring signal and the ideal signal (generated from the demodulated symbols) a control signal for the equalizer is extracted.

When analyzing the filter coefficients (trained equalizer state) with a FFT the compensating transfer function can be gained and from it the error function $E(f)$ can be gathered.

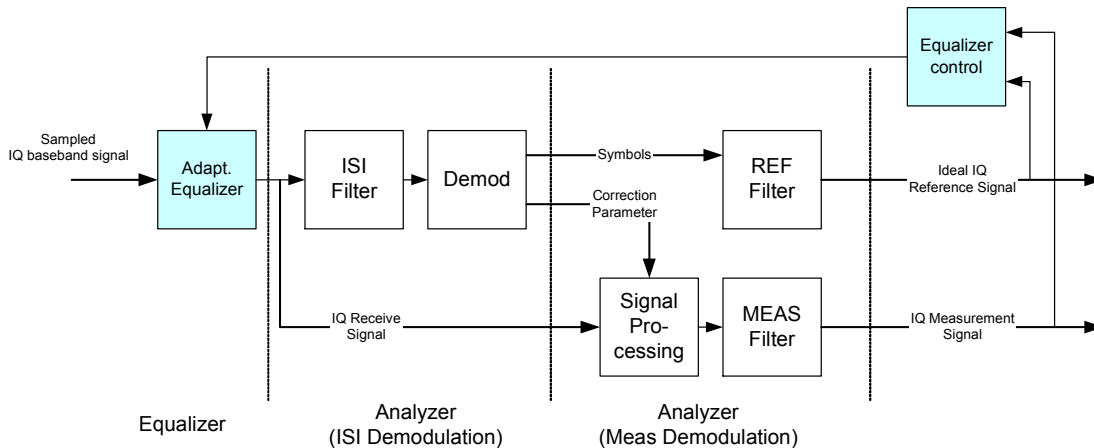

Fig. 35 Base band schematic: compensation of the transfer function's error by inserting an adaptive equalizer in the receive path

Another range of application is the analysis of an unknown or approximately known transmitter filter. The adaptive filter algorithm delivers a matched receiver filters for an intersymbol-interference-free demodulation when the following filter setting is set

- transmit filter = raised cosine
- receive filter = none
- measurement filter = none

The algorithm is limited to PSK and QAM modulation schemes, because of the optimization criterion of the algorithm is based on minimizing the mean square error vector magnitude. So it cannot be used for MSK, FSK and VSB schemes.

Training process of the equalizer

During operation of the equalizer we have to distinguish between two states:

TRAIN The equalizer is trained; the filter coefficients are continual adjusted by using the current demodulation results in order to minimize the RMS EVM. This process needs a lot of calculation so that the measurement update rate of the instrument decreases distinctly.

FREEZE The current filter coefficients are frozen, that means they no longer adapted. The display update rate increases distinctly again.

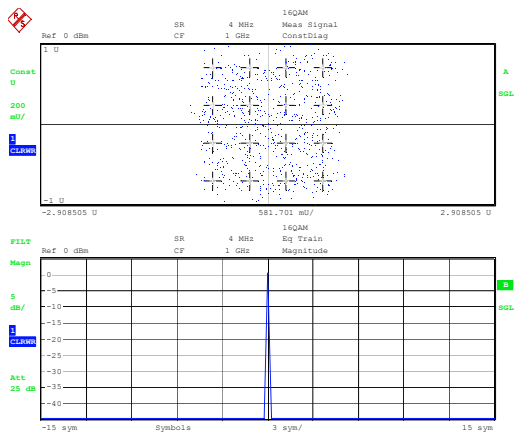

Training phase of the adaptive equalizer starts

The screen plot (upper diagram) shows a broad distribution of the constellation points (dots) around the ideal decision points (cross hairs)

The magnitude of the filter coefficients is shown in the lower part of the diagram in logarithmic scaling. The equalizer has not been trained yet, so a neutral filter is arranged in the signal path (all filter coefficients are zero, only the middle filter tap has the value 'one')

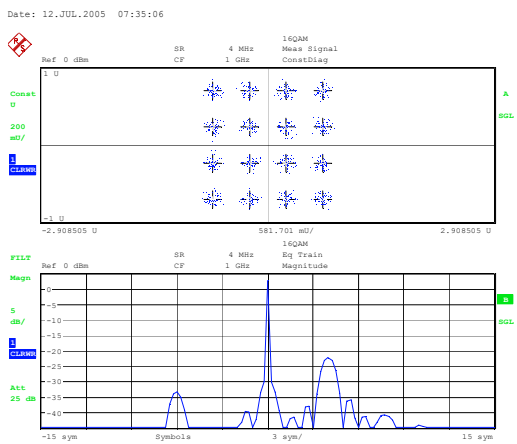

During the training phase

The screenshot (upper diagram) indicates a distinct improvement because of the variance of constellation points distribution has decreased observably. On either side of the adaptive filter's middle filter tap more non-zero coefficients are coming up (lower diagram). The logarithmic scaling makes the diagram very sensitive to Slight variations of the filter coefficients are easy to observe due to the logarithmic scaling of the diagram.

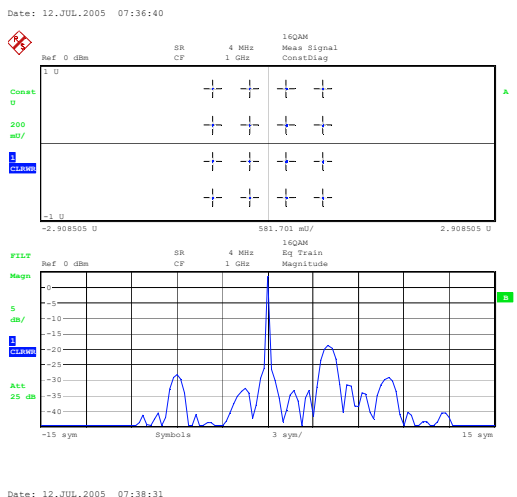

End of the training phase

The screenshot (upper diagram) indicates a nearly perfect constellation diagram. All constellation points are located close to their ideal positions in the cross hairs. The variance of the constellation distribution cannot be observed anymore. The accuracy of equalizer's coefficients has further improved and the number of non-zero coefficients has slightly increased. Please note that there are still some zero coefficients, so the filter length could be a little reduced for the shown measurement problem (saves calculation time during the equalizer's training phase).

Operating range of the Equalizer

The total frequency response can be flattened by the equalizer filter only in the pass-band of the transmitter- and receiver filter respectively. Because of the ideal reference signal doesn't generate any signal power outside of the pass-band, the equalizer eliminates most of the measurement signal's out of band power if necessary. The equalizer's out-of- band characteristic is mainly influenced by the existence or not-existence of any interfering signal power (e.g. noise, spurious signals, interfering signals).

- If there are any interfering out-of-band signals, the equalizer algorithm is going to suppress by its transfer characteristic (high out of band attenuation).
- If there are no interfering signals, there is no need for the equalizer to suppress out of band signals (flat but poor out-of-band attenuation).

The user has to consider this behavior when interpreting the filter's frequency characteristic.

The following figure exemplifies the equalizer's frequency response for a linear distorted measurement signal (raise cosine filter, alpha = 0.22). The optimization range is enhanced by red lines. An estimate of the pass-band with the pre-known signal parameters gives a good approximation to the equalizer's optimization range as demonstrated in the figure (signal has a very good signal to noise ratio, therefore the out-of band response is flat):

$$\text{Filter-bandwidth} = \text{symbol-rate} \cdot (1 + \alpha) = 4\text{MHz} \cdot 1.22 = 4.88 \text{ MHz}$$

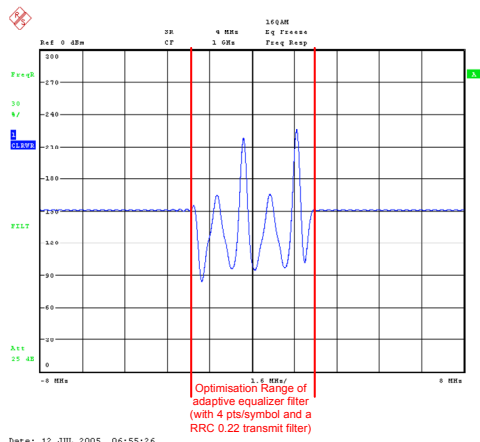
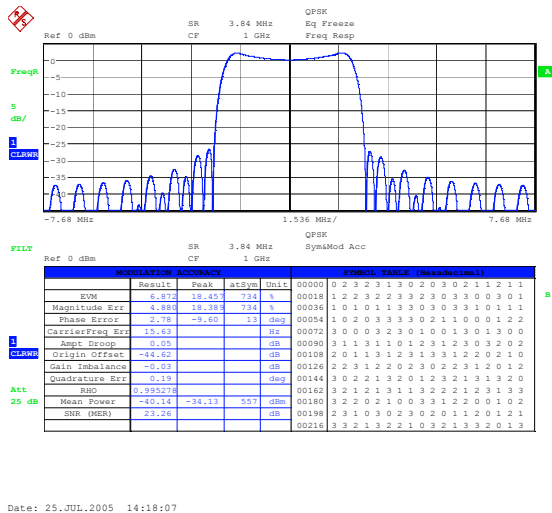

Fig. 36 Optimisation range of the adaptive equalizer filter

The adaptive equalizer's out-of-band transfer function is mainly influenced by the signal to noise ratio and interfering signals, as mentioned before. The algorithm tries to suppress any interfering signals in order to improve the RMS EVM value. Hence the out-of-band transfer function does not represent an inverse frequency response of the DUT or the channel.

The equalizer's frequency response to an input signal providing with poor SNR is shown in figure xx.yy whereas the response to a signal with good SNR is demonstrated in figure xx.zz. The left diagram (bad SNR) indicates a good suppression of interfering signals.



Date: 25.JUL.2005 14:18:07

Fig. 37 Upper diagram: frequency response of a trained equalizer filter (bad SNR at the instrument's input)

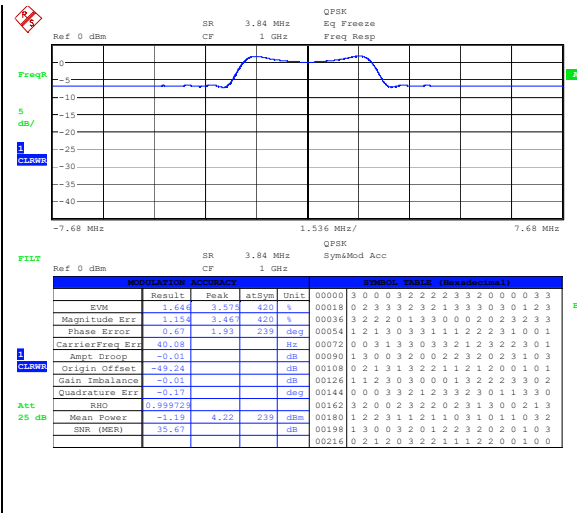

Date: 25.JUL.2005 14:16:44

Fig. 38 Upper diagram: frequency response of a trained equalizer filter (good SNR)

Symbol Mapping

Mapping or symbol mapping means that logic symbols or symbol numbers are assigned to points or transitions in the I/Q (e.g. PSK and QAM) or frequency plane (e.g. FSK).

Mapping in the analyzer serves for decoding the transmitted symbols from the sampled I/Q or frequency/time data records.

The mappings for all standards used in the analyzer and for all employed modulation modes are described in the following. Unless characterized otherwise, symbol numbers are specified in hexadecimal form (MSB at the left).

If logical symbol mapping does not exactly correspond to the display on the screen, the corresponding physical constellation diagram is shown in addition to mapping.

Phase Shift Keying (PSK)

With this type of modulation, the information is represented by the absolute phase position of the receive signal at the decision points. All transitions in the I/Q diagram are permissible for modulation types using static mapping. The complex constellation diagram is shown. The symbol numbers are entered in the diagram according to the mapping rule. The diagram displayed on the analyzer corresponds to symbol mapping.

BPSK (NATURAL)

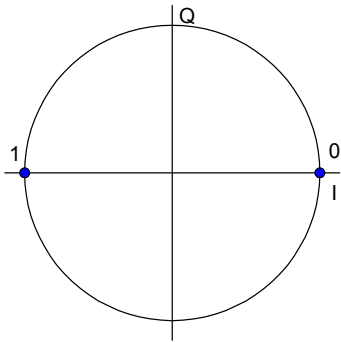

Fig. 39 Symbol mapping – BPSK / NATURAL

QPSK (WCDMA)

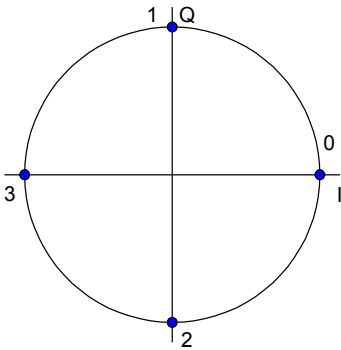

Fig. 40 Symbol mapping – QPSK / WCDMA

QPSK (CDMA2K_FWD)

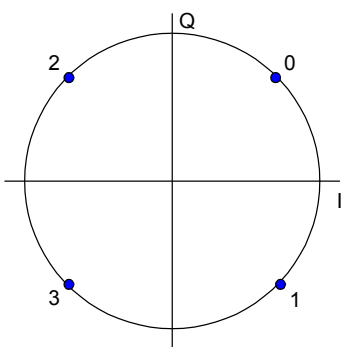

Fig. 42 Symbol mapping – QPSK / CDMA2K_FWD

QPSK (NATURAL)

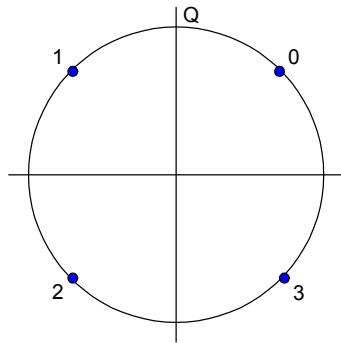

Fig. 41 Symbol mapping – QPSK / NATURAL

8PSK (NATURAL)

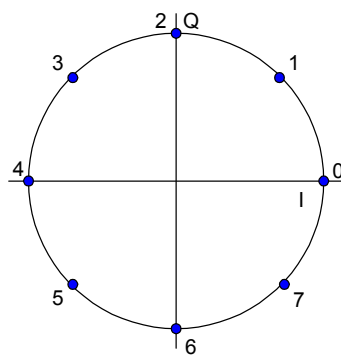

Fig. 43 Symbol mapping – 8PSK / NATURAL

Phase Offset PSK

With this type of modulation, the digital information is represented by the absolute position in the constellation diagram, a phase offset of ($n \cdot \phi_{\text{offset}}$) ($n = \text{symbol number}$) being taken into account for each I/Q symbol. This offset has the same effect as a rotation of the basic system of coordinates by the offset angle after each symbol.

This phase offset is automatically considered when the symbols are decoded and displayed.

The method is highly important in practical applications because it prevents signal transitions through the zeros in the I/Q plane. This reduces the dynamic range of the modulated signal and the linearity requirements for the amplifier.

In practice, the method is used for $3\pi/8$ -8PSK and (in conjunction with phase-differential coding) for $\pi/4$ -DQPSK.

The logical constellation diagram for $3\pi/8$ -8PSK comprises 8 points that correspond to the modulation level. A counter-clockwise offset (rotation) of $3\pi/8$ is inserted after each symbol transition.

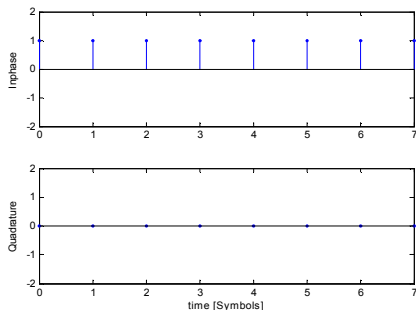

Fig. 44 I/Q symbol stream before $3\pi/8$ rotation

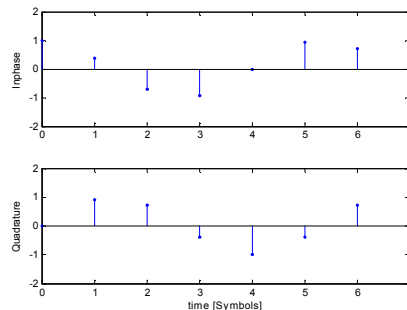

Fig. 45 I/Q symbol stream after $3\pi/8$ rotation

Fig. 44 and Fig. 45 illustrate the influence of the $3\pi/8$ rotation. Fig. 44 shows the I/Q symbol stream in the transmitter before rotation (corresponding to an 8PSK modulation), Fig. 44 after rotation ($3\pi/8$ PSK). $1+j \cdot 0$ was constantly assumed as the modulating symbol.

Fig. 46 and Fig. 47 show the corresponding display in the I/Q plane.

The logical constellation diagram (Fig. 46) comprises 8 points corresponding to the modulation level. When looking at the decision points of an ISI-free receive signal, a physical constellation diagram (Fig. 47) with 16 possible points is obtained.

Five symbol transitions are shown in the 'symbol 7' → 'symbol 7' diagram in Fig. 47.

3pi/8-8PSK (EDGE)

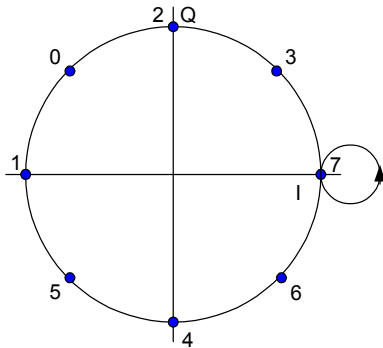

Fig. 46 Logical symbol mapping – 3pi/8-8PSK / EDGE

3pi/8-8PSK (display)

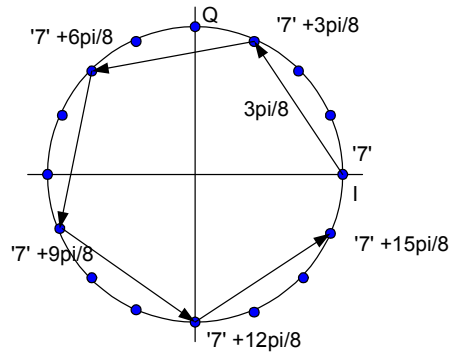

Fig. 47 Physical constellation diagram with ISI-free demodulation (taking into account the 3pi/8 phase offset)

Fig. 48 shows the TX filter prescribed for the EDGE standard. Fig. 49 shows the vector diagram of a transmitted EDGE signal and the reduced dynamic range of the signal in the case of phase offset modulation (eye aperture in the center of the diagram). The displayed signal is not filtered at the receiver end so that the ISI-free points cannot be seen in the diagram.

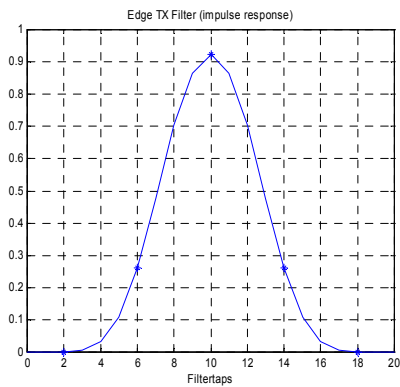

Fig. 48 EDGE TX filter

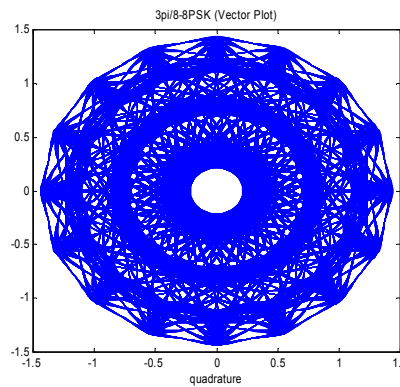

Fig. 49 Vector diagram: transmitted EDGE signal

Differential PSK

With differential PSK, the information is represented by the phase shift between two consecutive decision points. The absolute position of the complex sampling value at the decision point does not carry information.

In the **logical mapping diagram**, all permissible symbol transitions (phase transitions) are represented by points in the I/Q plane. The phase position of a point corresponds to the phase difference of the symbol transition. The arrow in the diagram highlights the phase shift and indicates the corresponding symbol number.

In the **physical constellation diagram**, the constellation points at the symbol decision points obtained after ISI-free demodulation are shown (as with common PSK methods). This diagram corresponds to the display on the analyzer. The position of the constellation points is standard-specific. For example, some QPSK standards define the constellation points on the diagonals, while other standards define the coordinate axes.

The symbol transitions at any constellation point in the diagram are indicated by arrows and labelled according to the mapping.

The indicated QPSK (ISAT) mapping corresponds to simple QPKS with phase-differential coding. Other types of modulation using this coding method are described in the section 'Mixed PSK modulation'.

DQPSK (INMARSAT)

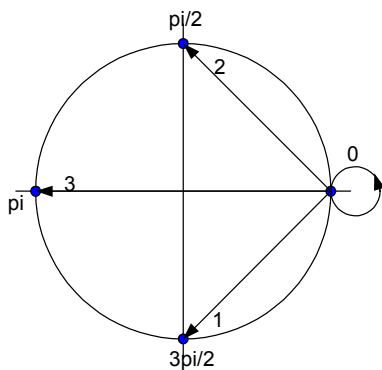

Fig. 50 Logical symbol mapping – DQPSK / INMARSAT

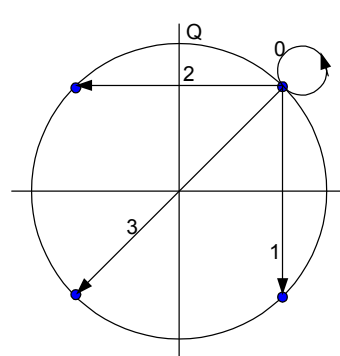

Fig. 51 Physical constellation diagram – DQPSK / INMARSAT

D8PSK (NATURAL)

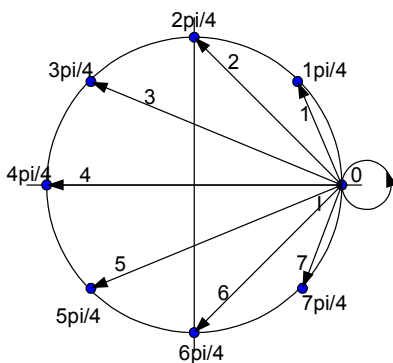

Fig. 52 Logical symbol mapping – D8PSK / NATURAL

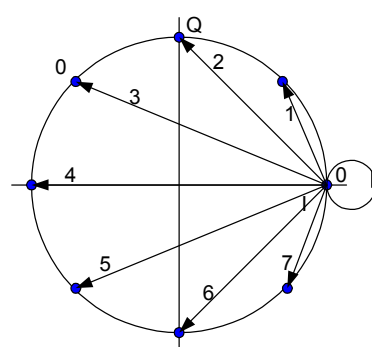

Fig. 53 Physical constellation diagram – D8PSK / NATURAL

Mixed PSK Modulation

Phase-differential modulation is frequently combined with an additional phase offset (e.g. $\pi/4$ DQPSK = $\pi/4$ phase offset modulation + differential modulated 4PSK).

The logical mapping diagram corresponds to the diagram for DPSK.

In the **physical constellation diagram**, the constellation points at the symbol decision points obtained after ISI-free demodulation are shown. This diagram corresponds to the display on the analyzer and, in the case of $\pi/4$ -QPSK modulation, the displayed constellation points are doubled.

$\pi/4$ DQPSK (NADC, PDC, PHS, TETRA)

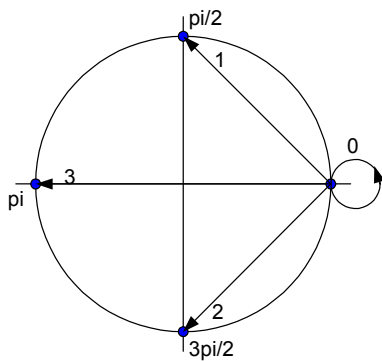

Fig. 54 Logical mapping – (NADC, PDC, PHS, TETRA)

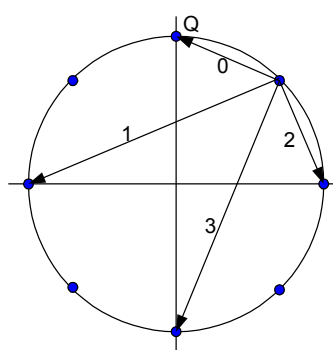

Fig. 55 Physical constellation diagram – $\pi/4$ -DQPSK (NADC, PDC, PHS, TETRA); the $\pi/4$ phase offset is taken into account

$\pi/4$ DQPSK (TFTS)

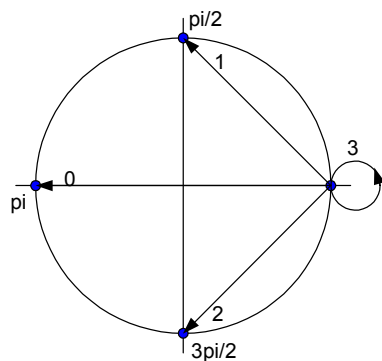

Fig. 56 Logical mapping – $\pi/4$ DQPSK (TFTS)

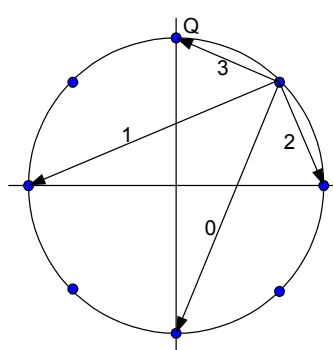

Fig. 57 Physical constellation diagram – $\pi/4$ DQPSK (TFTS); the $\pi/4$ phase offset is taken into account

Offset QPSK

With this method, the Q component is delayed by half a symbol period against the I component in the time domain. This method is used with QPSK and illustrated by the diagrams below.

Derivation of OQPSK

QPSK

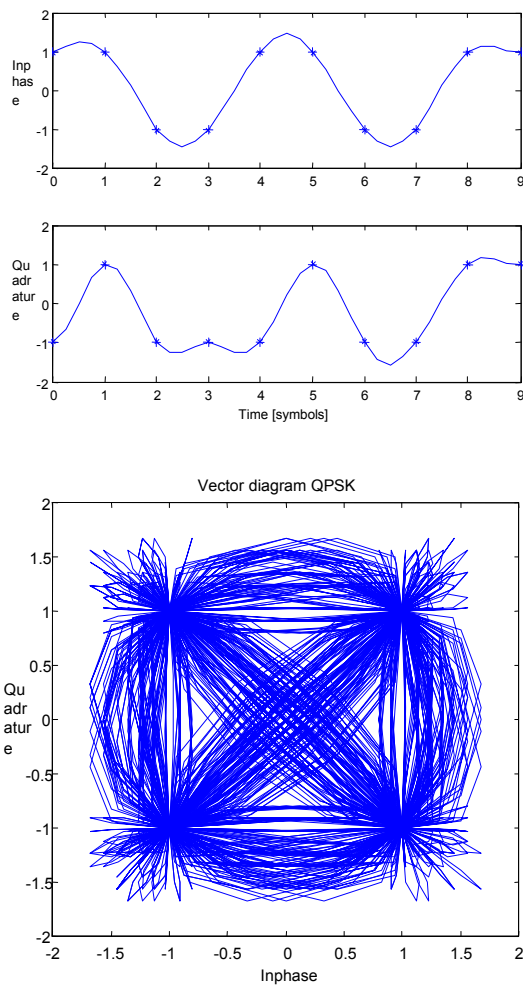

Fig. 58 PSK vector diagram with $\alpha = 0.35$

OQPSK (delayed Q component)

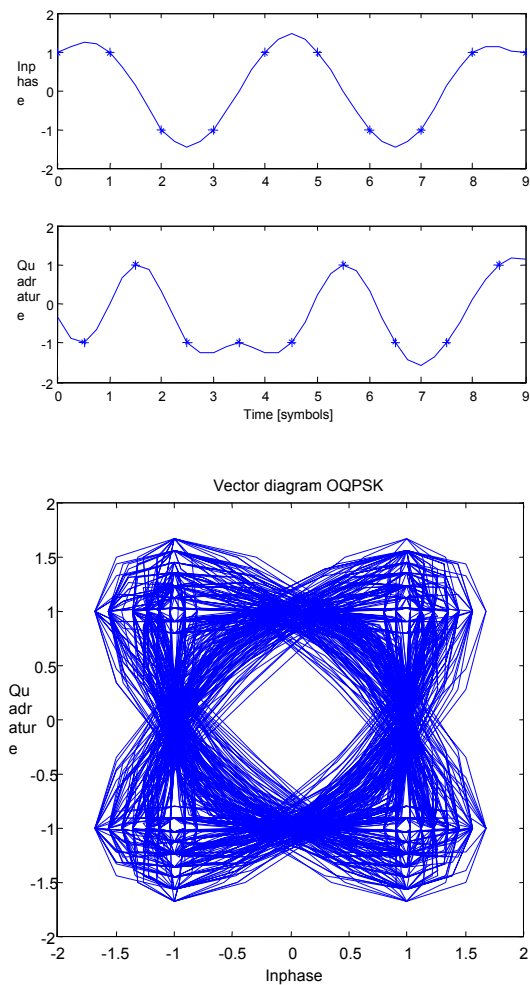

Fig. 59 OQPSK vector diagram with $\alpha = 0.35$

This method (as phase offset PSK) reduces the dynamic range of the modulated signal and the demands on amplifier linearity by avoiding the zero crossing.

A distinction is made in the analyzer display:

In the I/Q diagram (I/Q VECTOR), the time delay is not compensated for. The display corresponds to the physical diagram shown in (Fig. 59)

In the constellation diagram (I/Q CONSTELLATION), the time delay is compensated for. The display corresponds to the logical mapping (Fig. 60)

OQPSK (CDMA2K_REV)

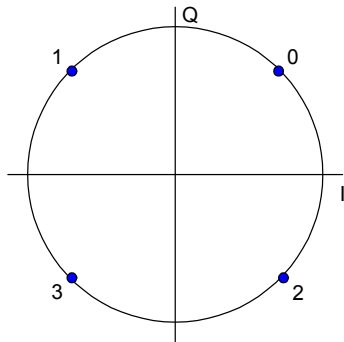

Fig. 60 Logical symbol mapping – OQPSK / CDMA2K_REV

Frequency Shift Keying (FSK)

In the case of FSK demodulation, a frequency/time diagram is displayed instead of the constellation and vector diagrams. The symbol decision is based on the signal frequency at the decision points. To illustrate the symbol decision thresholds, the symbol numbers are marked in the logical mapping diagram versus the instantaneous frequency f_i . The 0 frequency in the baseband corresponds to the input frequency of the analyzer.

2FSK (NATURAL)

With 2FSK, the symbol decision is made by a simple frequency discriminator with reference to the 0 frequency in the baseband:

$$s(t) = \begin{cases} 1 & \text{for } f_i(t) \geq 0 \\ 0 & \text{for } f_i(t) < 0 \end{cases}$$

for all symbol decision points $t = n \cdot T_s$,
 f_i = instantaneous frequency normalized to FSK REF DEVIATION

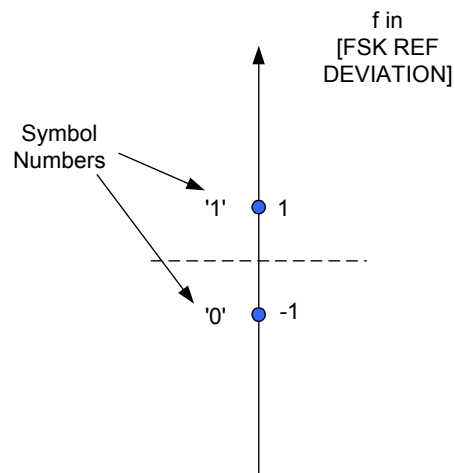

Fig. 61 Symbol mapping – 2FSK / NATURAL

4FSK

With 4FSK, the symbol decision is made by a frequency discriminator with 3 decision thresholds (-2/3; 0; +2/3) normalized to the FSK REF DEVIATION parameter.

$$s(t) = \begin{cases} 0 & \text{for } f_i(t) < -\frac{2}{3} \\ 1 & \text{for } -\frac{2}{3} \leq f_i(t) < 0 \\ 2 & \text{for } 0 \leq f_i(t) < \frac{2}{3} \\ 3 & \text{for } \frac{2}{3} \leq f_i \end{cases}$$

for all symbol decision points $t = n \cdot T_s$,
 f_i = normalized instantaneous frequency

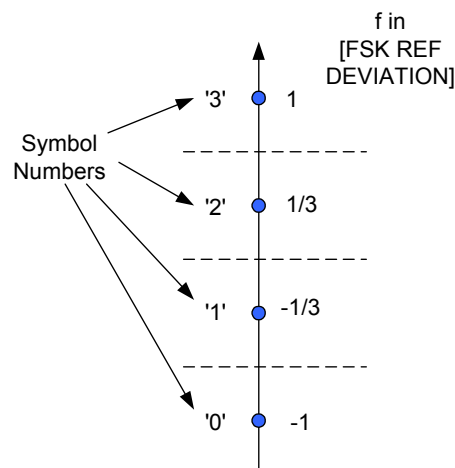

Fig. 62 Symbol mapping – 4FSK / NATURAL

Minimum Shift Keying (MSK)

MSK modulation is a special case of 2FSK with FSK REF DEVIATION = $\frac{1}{4}$ * symbol rate. This special characteristic causes modulation-dependent phase shifts of $\pm 90^\circ$ which can be shown in an I/Q constellation diagram. As with PSK, demodulation is performed by evaluation of the phase positions.

MSK (NATURAL)

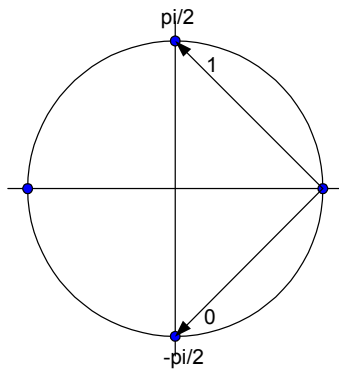

Fig. 63 Logical symbol mapping – MSK / NATURAL

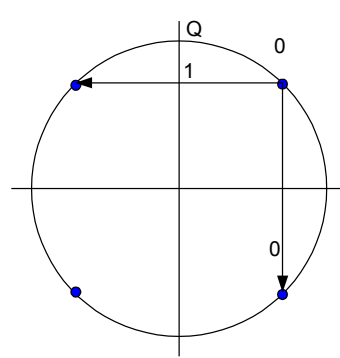

Fig. 64 Physical constellation diagram – MSK

Similar to PSK, differential coding can also be used with MSK. In this case, too, the information is represented by the transition of two consecutive symbols. The block diagram of the coder is shown below.

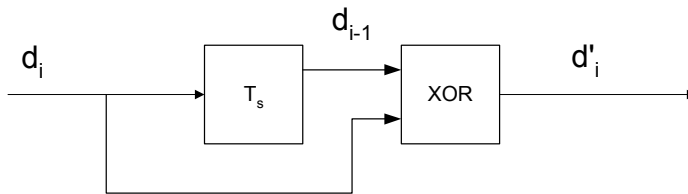

Fig. 65 DMSK: differential encoder in the transmitter

d_i input symbol {0;1} of differential encoder

d_{i-1} input symbol delayed by the symbol period T_s

d'_i output symbol {0;1} of differential encoder

During demodulation and symbol decision in the analyzer, the original symbols are restored by a differential decoder and displayed.

This modulation method used for the digital GSM standard in conjunction with a GAUSSIAN transmitter filter is called GMSK.

Signal mapping with the differential encoder is called MSK / GSM.

Quadrature Amplitude Modulation (QAM)

In the case of QAM the information is represented by the signal amplitude and phase. The symbols are arranged in a square constellation (16, 64, 256QAM) or as cross-shaped structures (21, 128QAM) in the I/Q plane.

The differential mappings below meet ETSI EN 300429 V1.2.1 (DVB-C).

Important: To ensure reliable demodulation, the statistical distribution of the available symbol quantity should be as even as possible.

For instance, if only

- single symbols
- single amplitude ranges or
- single quadrants

are used, demodulation errors may occur. As a rule of thumb, the RESULT LENGTH should correspond to at least 8 times the modulation level. For example, with 64 QAM a RESULT LENGTH of at least $4 \cdot 64 = 256$ symbols should be used.

Statistical QAM Mappings

The following QAM mappings are obtained from the mapping of the 1st quadrant, which is always rotated by $\pi/2$ for the subsequent quadrants and supplemented by a (GRAY-coded) prefix for each quadrant.

Derivation of QAM mappings

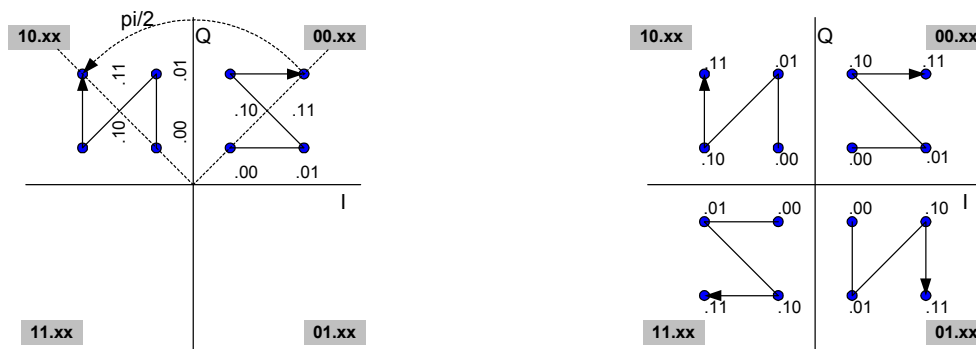

Fig. 66 Rotation of 1st quadrant

In the following diagrams, the symbol mappings are indicated in hexadecimal and binary form.

16QAM (DVB-C)

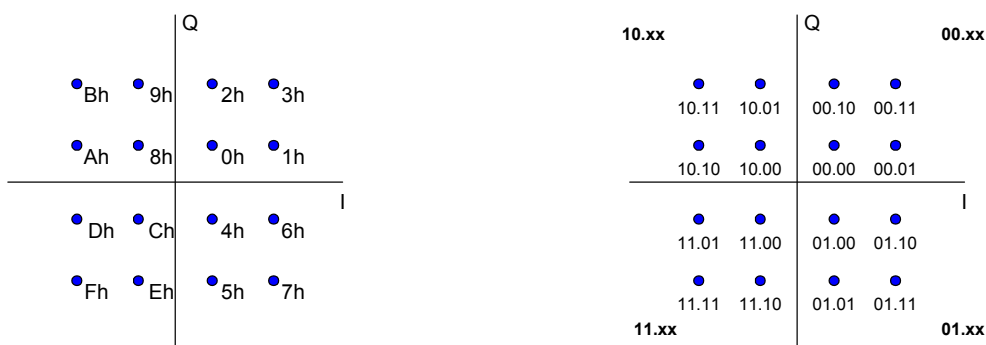

Fig. 67 Symbol mapping – 16QAM / DVB-C

32QAM (DVB-C)

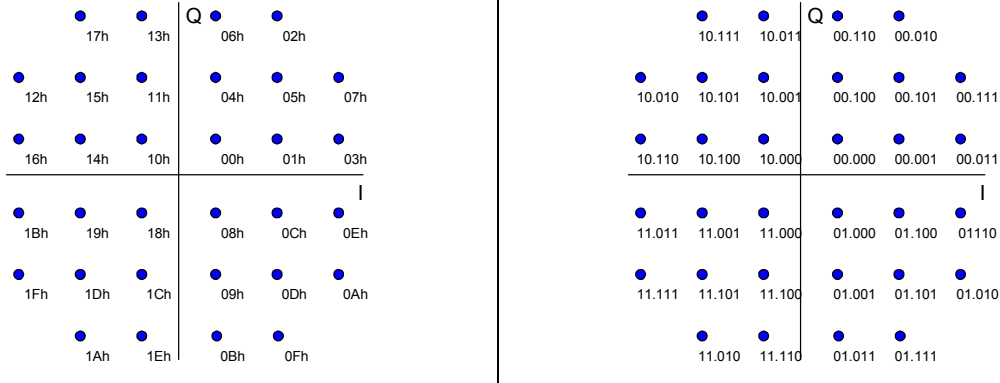

Fig. 68 Symbol mapping – 32QAM / DVB-C

64QAM (DVB-C)

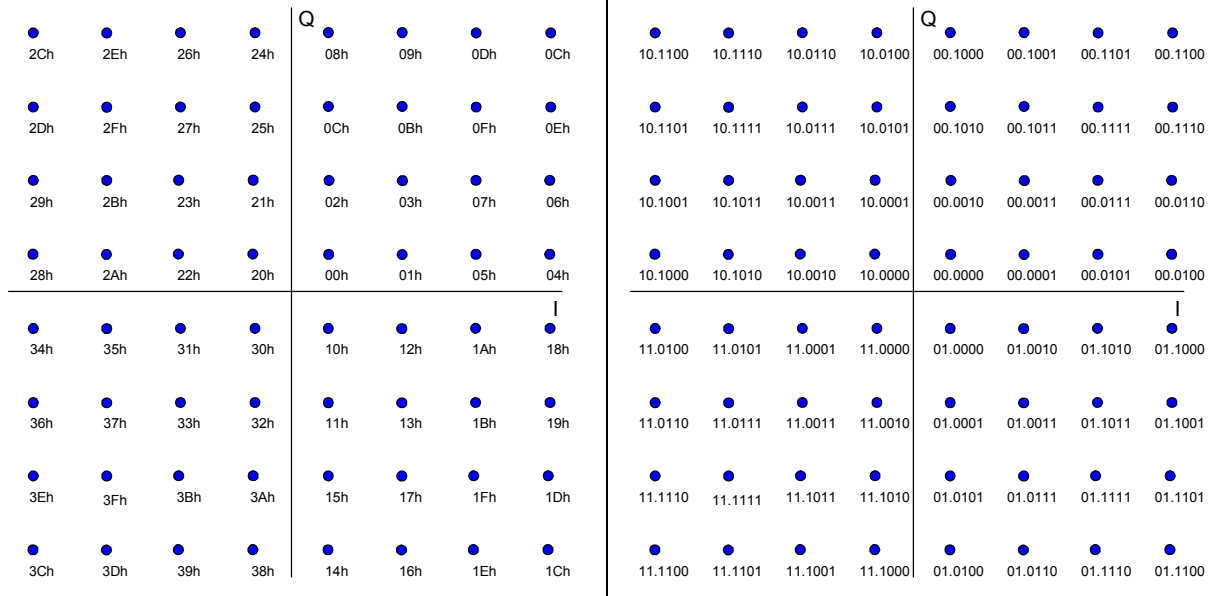

Fig. 69 Symbol mapping – 64QAM / DVB-C

128QAM (DVB-C)

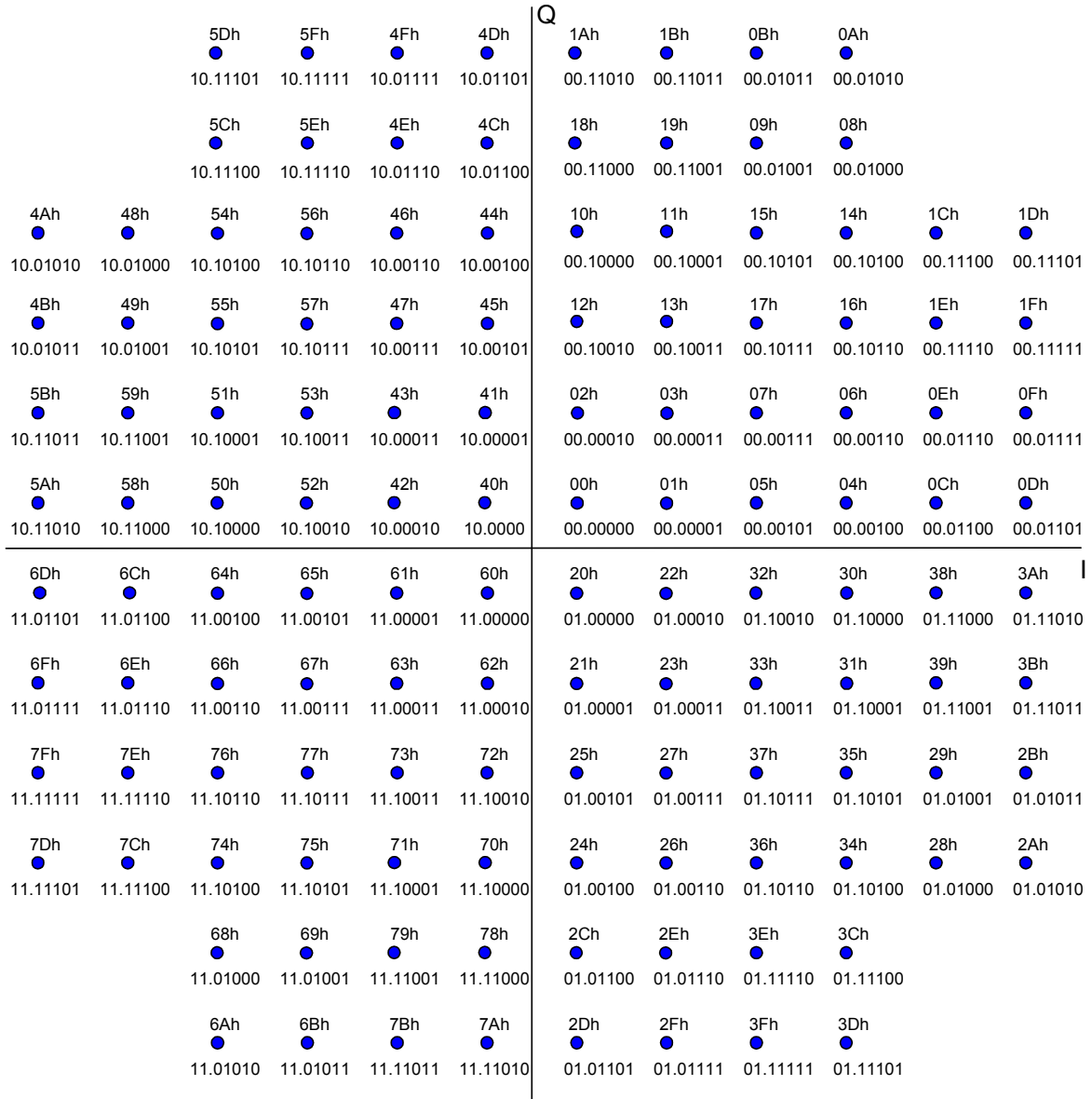

Fig. 70 Symbol mapping – 128QAM / DVB-C

256QAM (DVB-C)

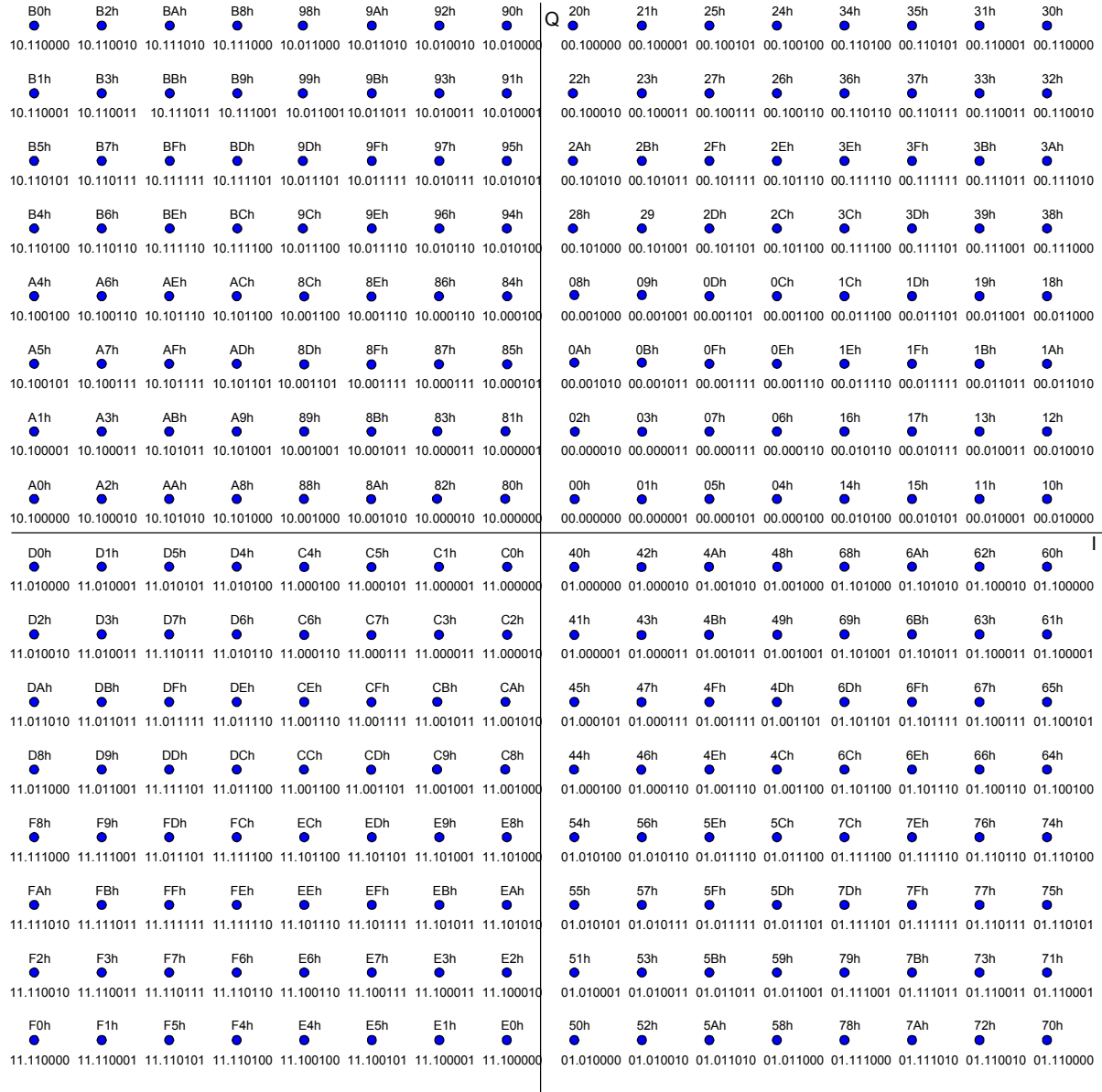

Fig. 71 Symbol mapping – 265QAM / DVB-C

Differential QAM Mappings

The following differential QAM mappings show the mapping in a quadrant (1st quadrant) and differential mapping. In the case of differential mapping, the quadrant transitions are coded (as with DQPSK).

Differential 16QAM (DVB-C)

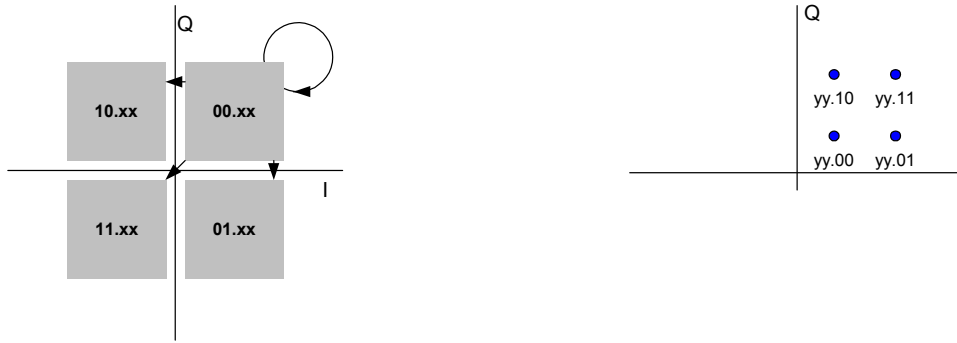

Fig. 72 Symbol mapping – D16QAM / DVB-C

Differential 32QAM (DVB-C)

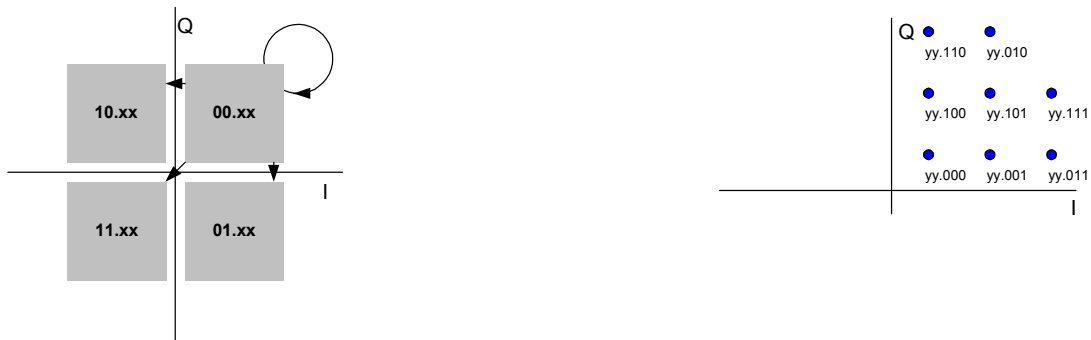

Fig. 73 Symbol mapping – D32QAM / DVB-C

Differential 64QAM (DVB-C)



Fig. 74 Symbol mapping – D64QAM / DVB-C

Differential 128QAM (DVB-C)

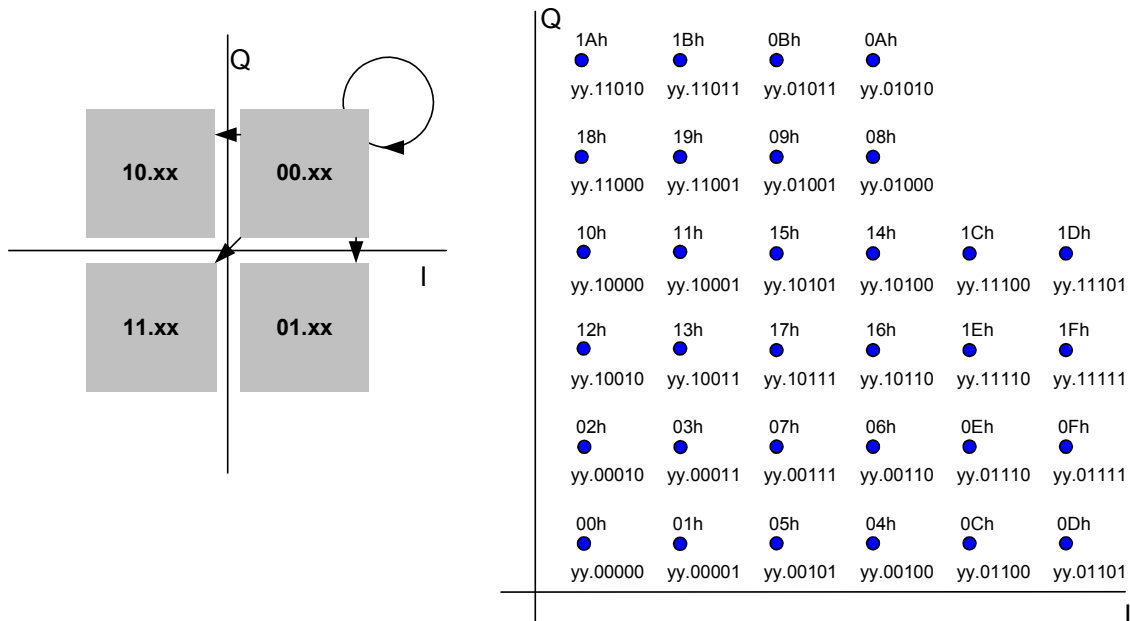

Fig. 75 Symbol mapping – D128QAM / DVB-C

Differential 256QAM (DVB-C)

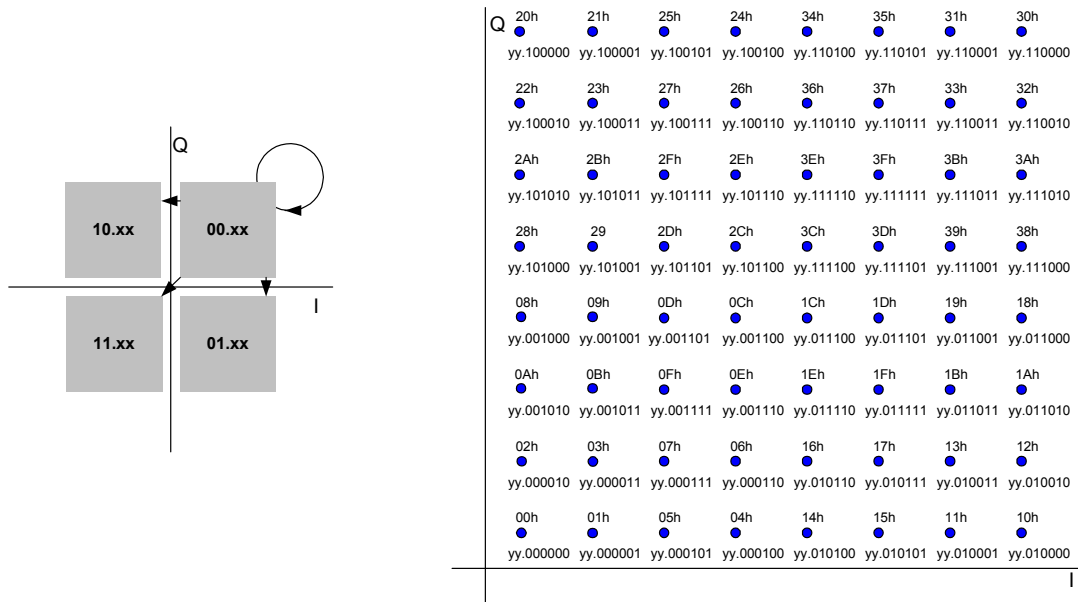

Fig. 76 Symbol mapping – D256QAM / DVB-C

User Defined Constellations (USER-QAM)

Customized constellations (including symbol mappings) can be defined with the external utility MAPWIZ (PC Windows environment).

For a description of this tool see chapter 8, "[Utilities /External Programs](#)".

The example in the following figure shows the constellation diagram of the 16-level USER-QUAM that has the minimum probability of symbol errors in the case of AWGN (Source: "Optimization of Two-Dimensional Signal Constellations in the Presence of Gaussian Noise", G. J. Foschini et al., IEEE Transactions on Communications, Vol. COM-22, 01/1974, pp. 28).

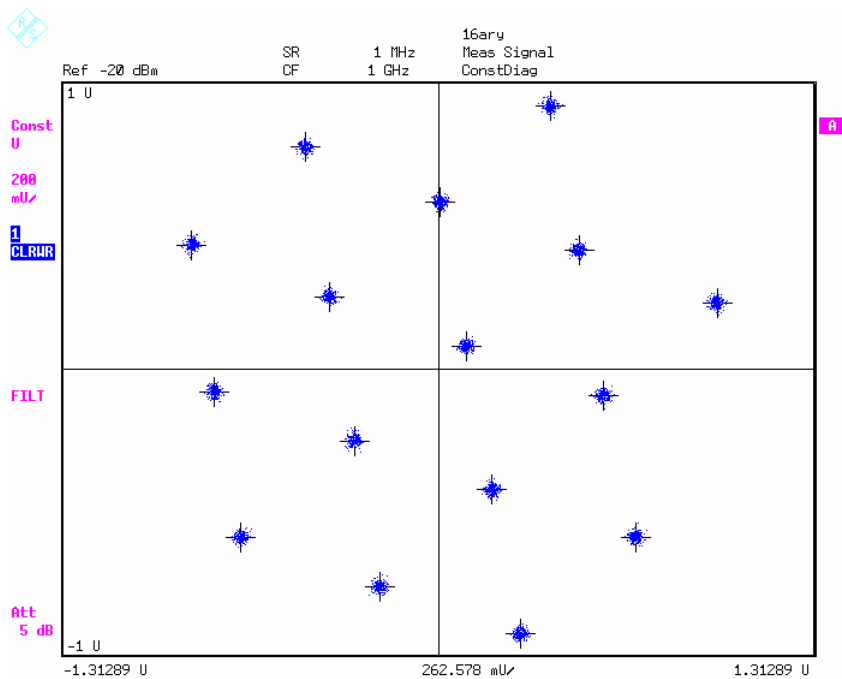

Fig. 77 Demodulation of a 16ary USER-QAM

Vestigial Sideband Modulation (VSB)

Like BPSK, digital vestigial sideband modulation (VSB) transfers the information in the real component, in which case different amplitude stages must additionally be used. Owing to the real baseband signal, transmitting a single sideband is sufficient, e.g. VSB signals have half the bandwidth of BPSK signals. Rather than completely suppressing one of the two sidebands, a vestige of the sideband to be suppressed is permitted, thus reducing the effort for implementing filters. However, halving the bandwidth produces intersymbol interference (ISI), which is indicated by vertical lines in the constellation diagram (see Fig. 78).

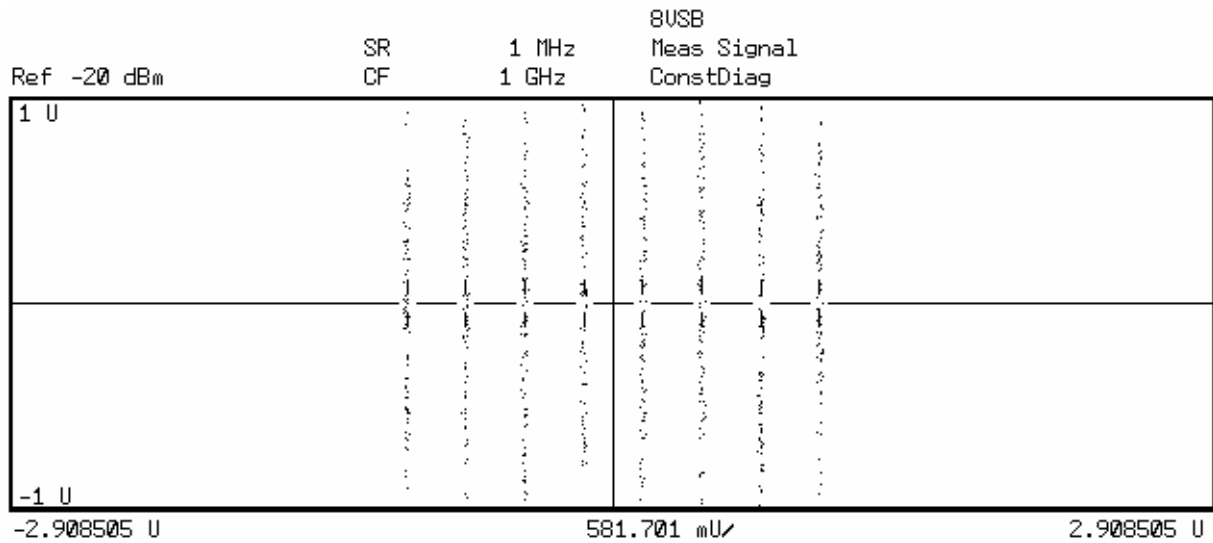

Fig. 78 8VSB constellation diagram

A further and primary difference compared to PSK methods is that VSB signals additionally contain a pilot carrier. The pilot carrier is removed from the signals for all measurements (except capture buffer). To make it possible to analyze VSB signals with the vector signal analyzer, the center frequency and the frequency position (normal position or inverted position) must be adjusted in such a manner that a spectrum that is symmetrical about the center frequency is present at the analyzer input. In this case, the pilot carrier must be located to the left of the center frequency (see Fig. 79). Compared with the true VSB spectrum that has been freed from the pilot carrier (see Fig. 80), the spectrum must be shifted to the left by symbol rate/4.

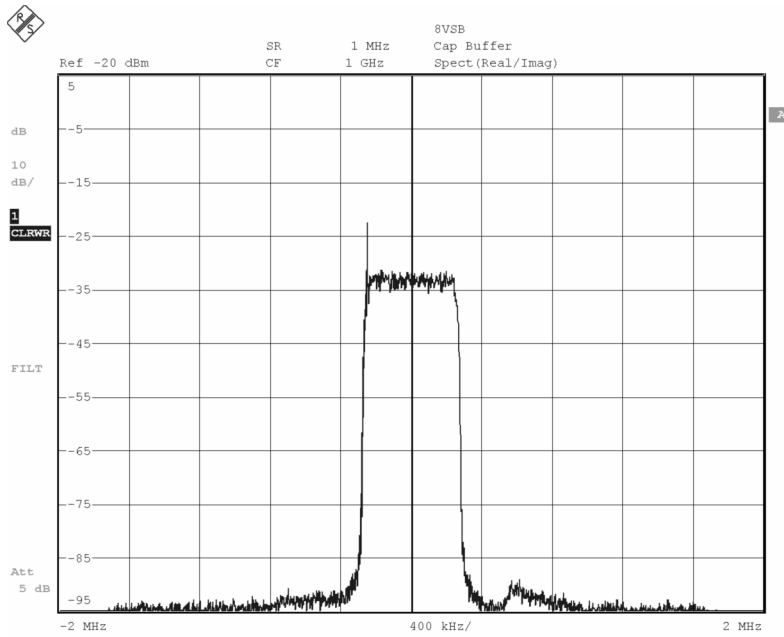

Fig. 79 8VSB spectrum at the input of the analyzer (pilot carrier visible to the left)

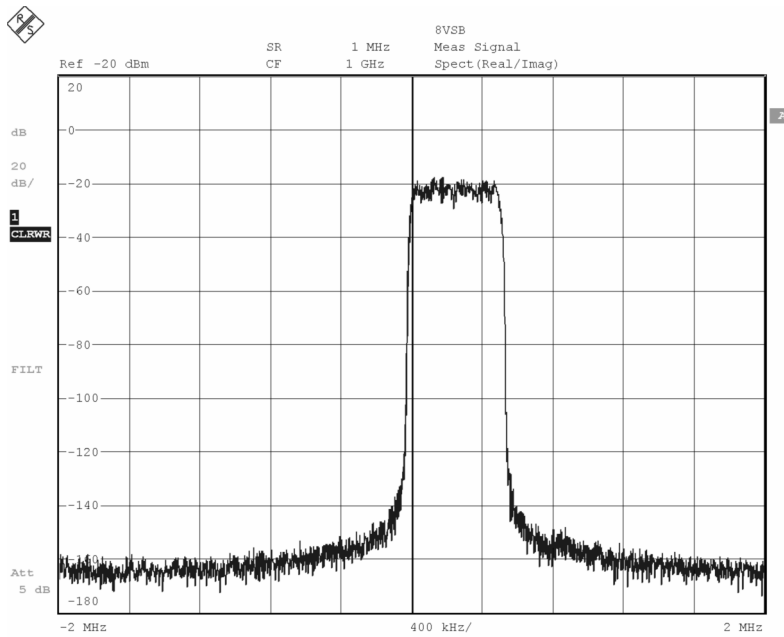

Fig. 80 Spectrum of measurement signal 8VSB (pilot carrier always removed)

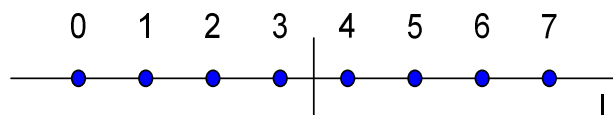

Fig. 81 Symbol mapping 8VSB (ATSC)

Demodulation and Algorithms

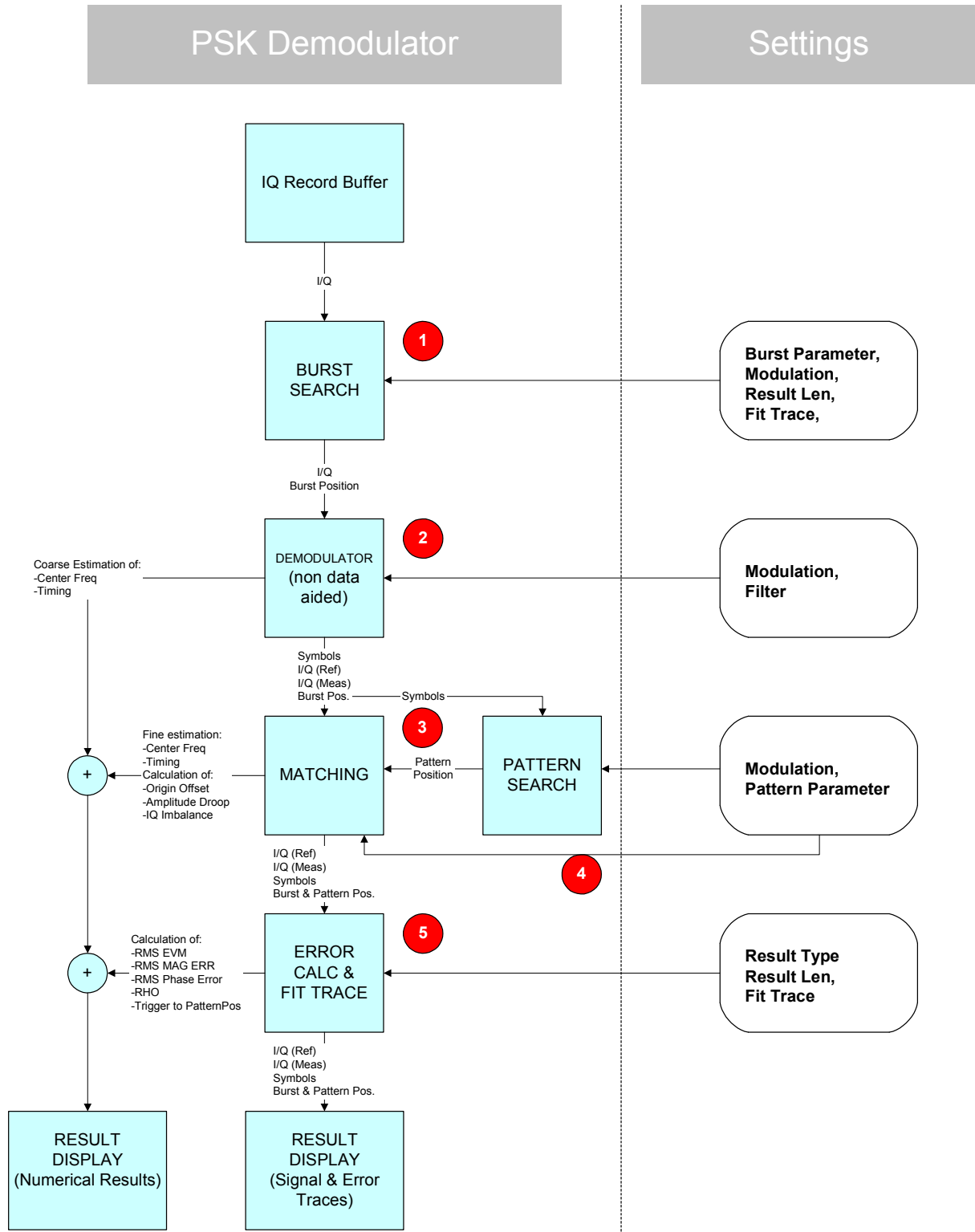

Fig. 82 Digital demodulation of a PSK demodulator

Fig. 82 gives an overview of the demodulation stages of the vector signal analysis option, using PSK demodulation as an example. Differences to other types of modulation will be dealt with at the end of this chapter.

The function blocks for demodulation are shown at the left, settings for the function blocks at the right.

After data recording in the RECORD BUFFER, the I/Q data is forwarded to the

BURST SEARCH

In this stage, the RECORD BUFFER is searched through for burst structures. The first burst found is forwarded together with its environment to the next processing stage.

The length of the transferred data record normally corresponds to the RESULT LENGTH. The internal length may be automatically extended because of the delays required by the demodulation filters to settle and for trace positioning in the display (FIT TRACE).

If the burst search is switched off, a data record from the beginning of the RECORD BUFFER is transmitted.

DEMODULATOR

This stage performs demodulation down to symbol level. Correction values for timing, frequency and phase position are determined during demodulation and applied to the data record so that a correct symbol decision is possible. Network-specific synchronization aids such as sync patterns are not used in this case so that the measurement demodulator operates without knowing the transmitted data contents (NDA (non-data-aided) demodulator). A reference signal corresponding to an ideal, error-free transmission signal is regenerated from the various symbols and forwarded to the MATCHING stage together with the corrected measurement signal.

PATTERN SEARCH

The symbol data record is searched through for one or more user-defined sync patterns. The measurement results (TRACES) can be positioned with the aid of the patterns found. The pattern search is optional.

MATCHING

In this stage the reference and measurement signals are correlated. The matching algorithm determines accurate correction values for signal amplitude and signal timing as well as for frequency errors and phase position of the measurement signal with the aid of the optimization criterion in order to minimize the RMS vector error, and then corrects the measurement data record.

First numeric measurement results such as center frequency error, origin offset and I/Q imbalance are obtained at this stage.

ERROR CALC & FIT TRACE

At this processing stage, further modulation errors are calculated which are either displayed as results or used for further result calculation. Results are available in numeric form (e.g. RMS EVM), display versus time (EVM trace) or as a statistical evaluation of error parameters (e.g. 95:th percentile).

RESULT DISPLAY

The selected measurement results are positioned in the display and scaled according to user settings. Special points in time or ranges of the measurement signal (e.g. sync pattern or symbol decision points) can be highlighted in the display.

A detailed description of the function blocks follows on the next pages.

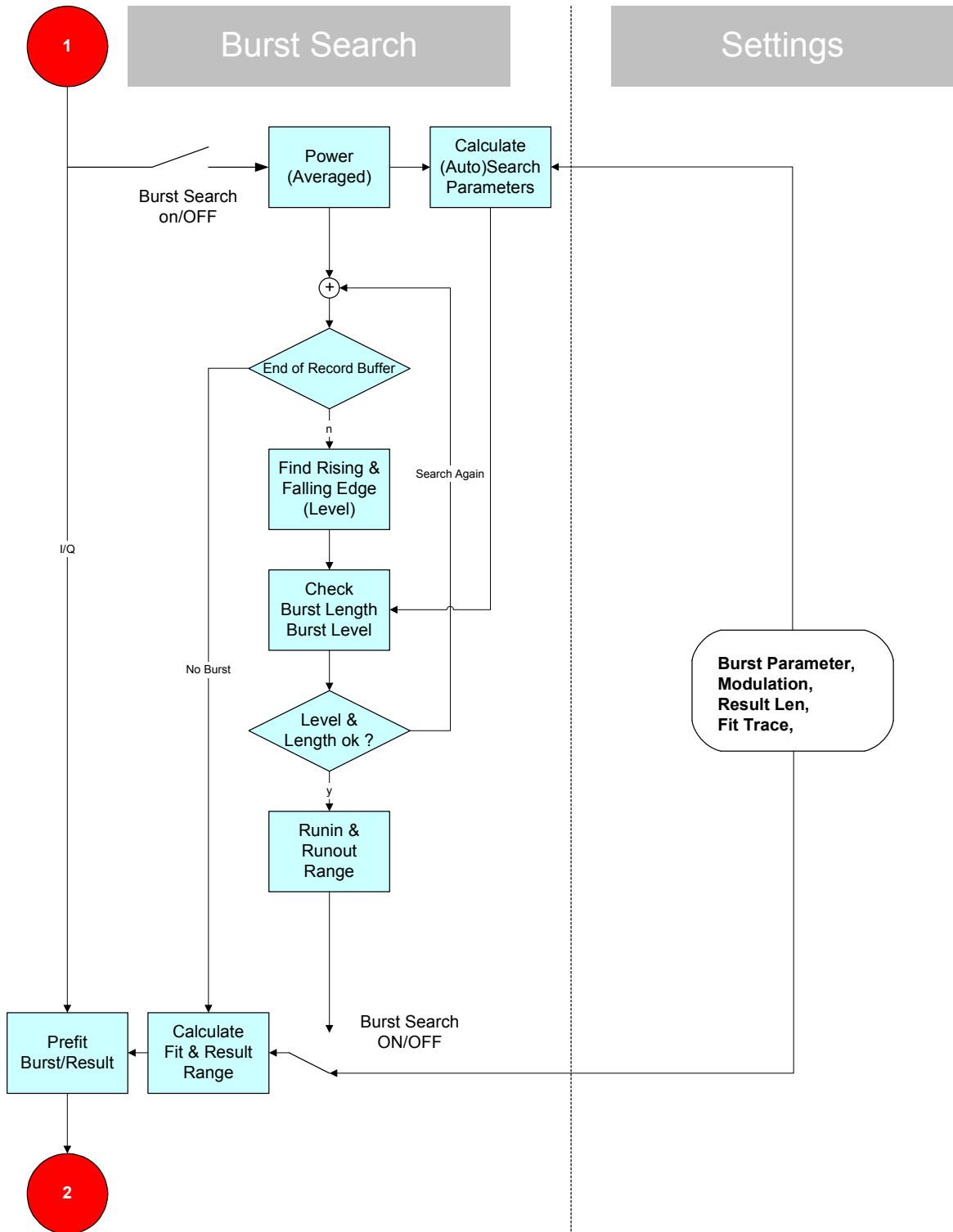

Fig. 83 Burst Search

Burst Search

With the **burst search switched on**, the magnitude of the sample in the record buffer is calculated and then averaged with a square filter to reduce modulation-responsive signal amplitude variations and to suppress short noise peaks.

In the **AUTO** mode, the global minimum and maximum of this data record are determined and two level threshold values are calculated by taking into account a modulation-responsive factor.

With the aid of these thresholds, the magnitude data record is searched through for rising and falling burst edges. Brief level drops are ignored.

When the first burst is found that fulfills the requirements regarding minimum and maximum length, the burst search is terminated and the part of the record buffer containing the burst is forwarded to the subsequent processing stage.

The minimum and maximum lengths that can be detected, the calculation of threshold values and the sensitivity for short level drops can be varied in the AUTO mode by selecting a digital standard.

In the **MAN** (manual) mode, these parameters can be set by the user. However, the MAN mode is only recommended under difficult receive conditions.

If the **burst search is switched off**, a block with a length required for result display from the beginning of the record buffer is forwarded to the next processing stage.

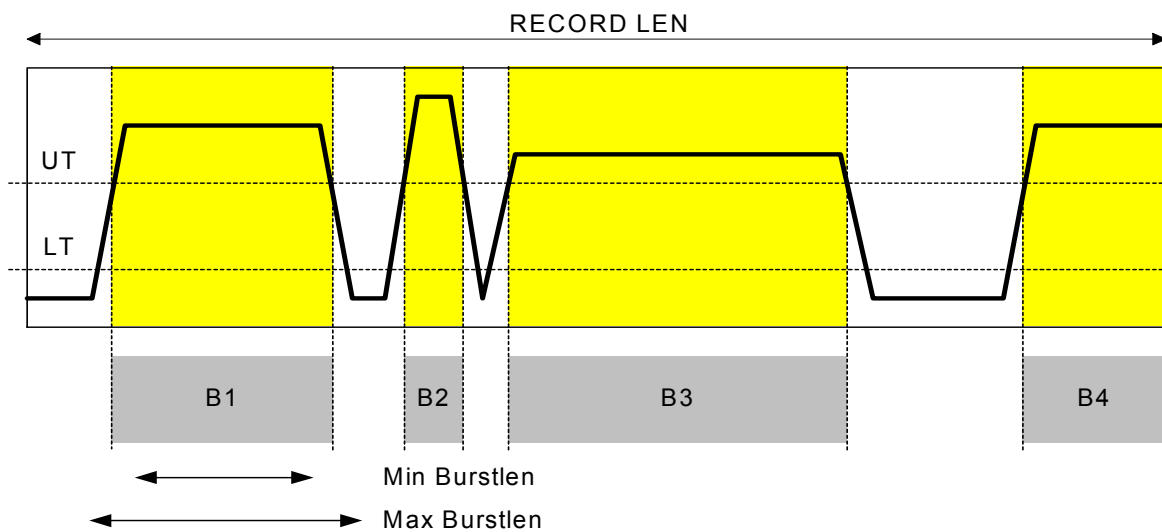

Fig. 84 Record buffer containing several bursts

Fig. 84 shows the contents of a record buffer with several bursts.

The upper (UT) and the lower burst threshold (LT) and bursts of different levels are shown.

All bursts fulfill the level requirements, i.e. the burst edges cross both burst thresholds; burst B1 also has the required length, B2 is too short, B3 is too long and B4 has no falling burst edge.

B1 is the first burst to fulfill all requirements and therefore forwarded to the subsequent processing stages.

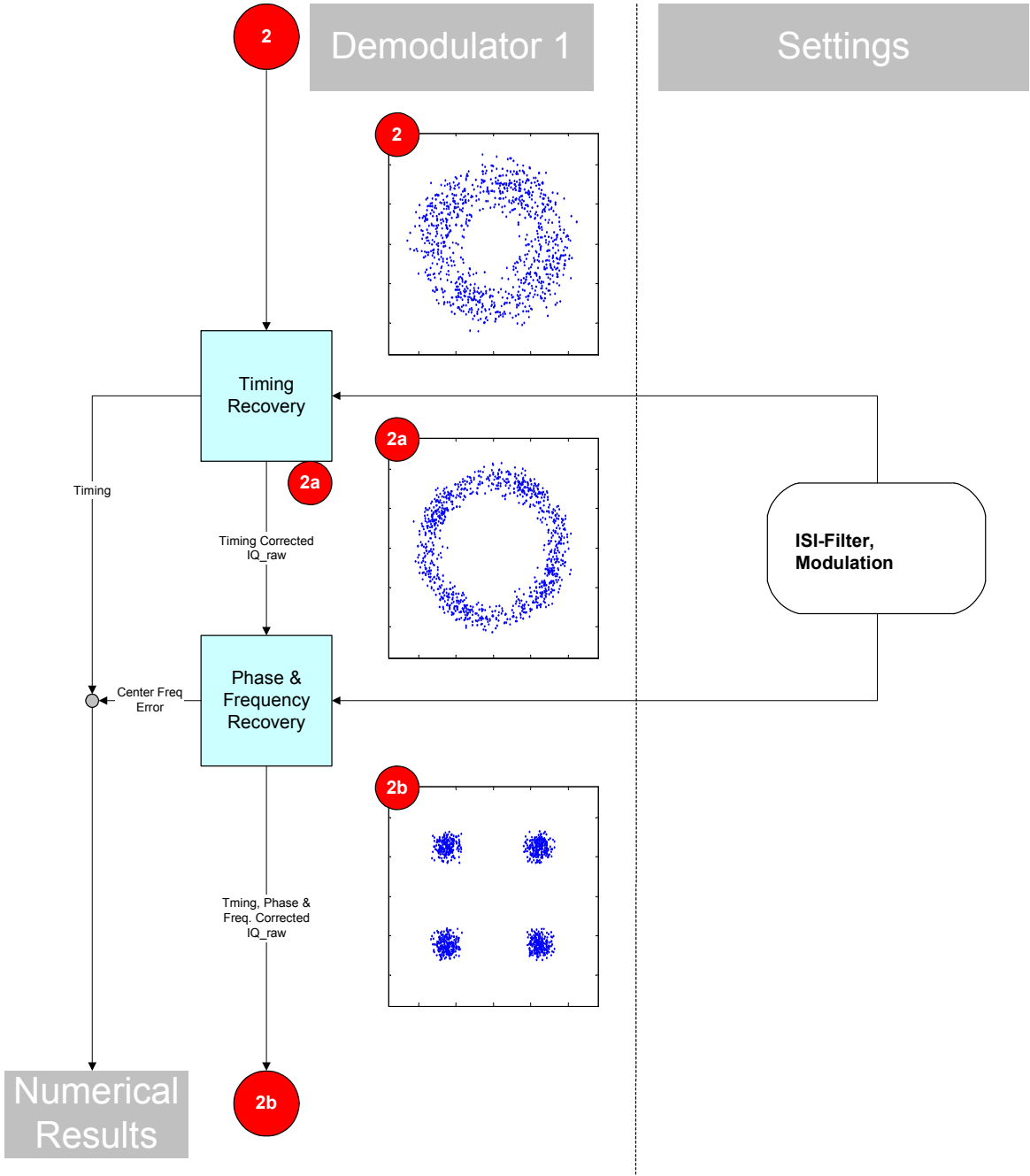

Fig. 85 I/Q demodulator: timing, phase, frequency recovery

Demodulator 1

The first part of the demodulator comprises the following function groups:

- Timing recovery
- Phase & frequency recovery

If a burst structure is found, the burst (without edges) is used as the demodulator estimation range although the determined correction parameters are applied to the full demodulation range.

For reasons of algorithm, the signals are filtered in these function blocks to obtain ISI-free points. However, the output signals are timing-, frequency- and phase-corrected raw signals (as shown in the drawings) so that subsequent distortion measurements can be performed or customized measurement filters used.

At the input of this stage, the I/Q data record in the complex baseband contains

- a time offset τ ;
- a center frequency error and a phase error of $\Delta\varphi_0$.

Timing Recovery

This function group determines the ideal symbol decision points in the signal. The I/Q data record must then be corrected so that the samples occur exactly at the symbol decision points (resampling).

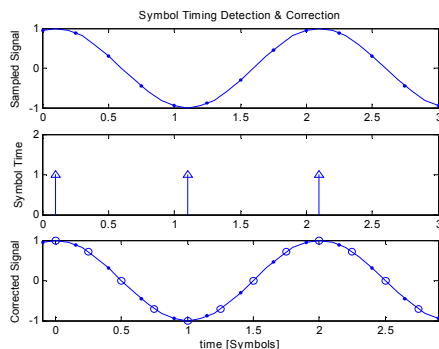

Fig. 86 Symbol timing detection & correction

Fig. 86 illustrates the correction using the sampled input signal, the ideal symbol decision points and the corrected data record (time axis adapted).

A calculated timebase correction also affects numeric results (e.g. trigger to sync measurement).

SIGNAL 2 (Fig. 85) corresponds to the I/Q data record before timing correction, **SIGNAL 2a** to the record after timing correction. Since the frequency error is not yet eliminated, the symbol points in the constellation diagram are shown as a circular band.

Phase & Frequency Recovery

This function group determines and corrects the frequency and phase offset. With the aid of a robust, maximum-likelihood frequency and phase estimator, the stage determines the optimum estimation value for the data record after timing correction (center frequency error $\Delta\varphi_0$).

After correction of these quantities, a 'non-rotating constellation diagram' (for an unfiltered raw signal) is obtained (see **SIGNAL 2b**).

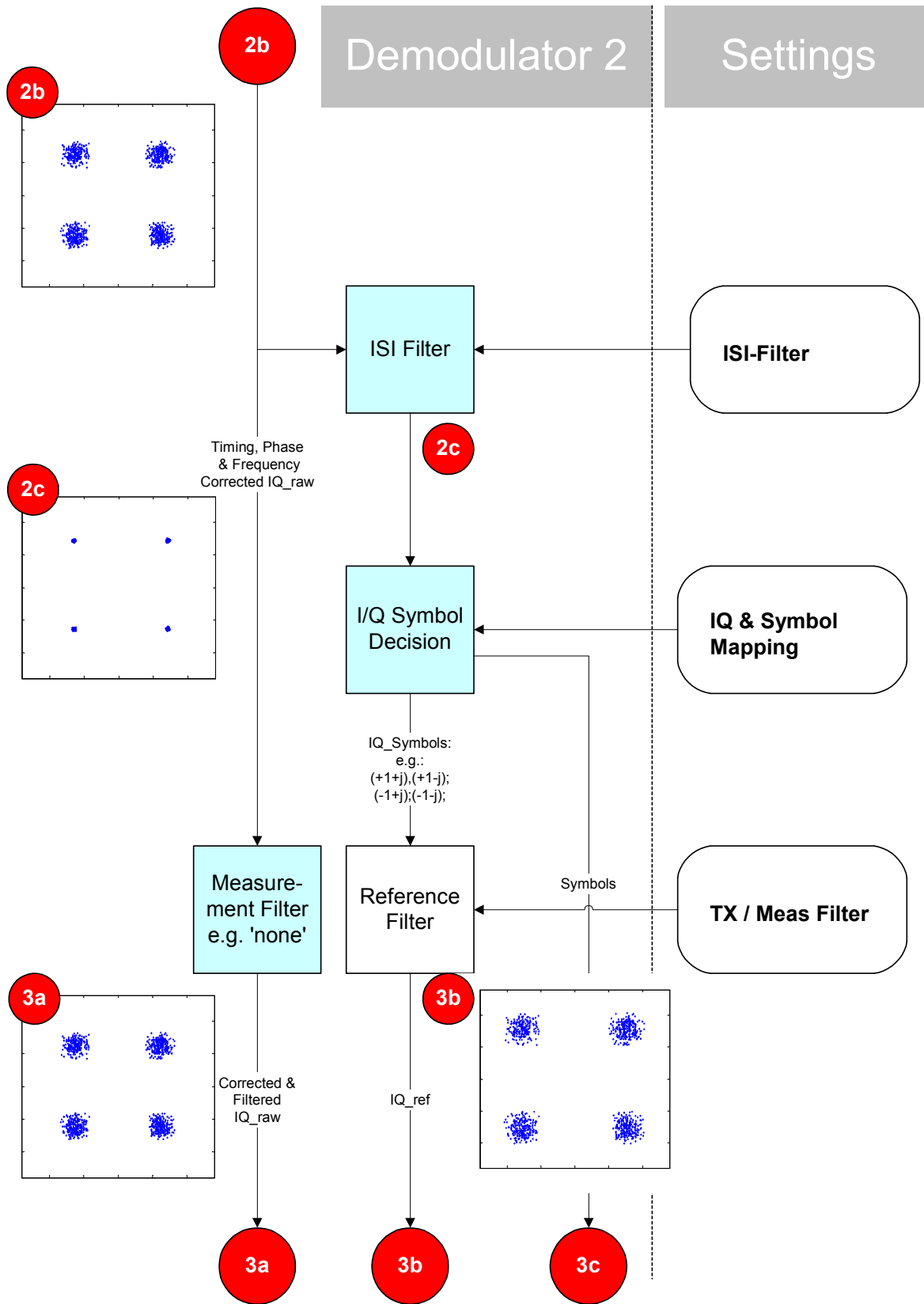

Fig. 87 Demodulator 2

Demodulator 2

The timing-, frequency- and phase-corrected data record (signal 2b) is forwarded to an **ISI FILTER** to eliminate the ISI of adjacent symbols (see section "[System-Theoretical Modulation and Demodulation Filters](#)").

I/Q symbols (signal 3c) and - if symbol mappings are taken into account - logical symbols are then produced in the **I/Q SYMBOL DECISION** block (for PSK).

In the case of QPSK, the segment decoder is a simple quadrant decoder which only affects the input signal phase.

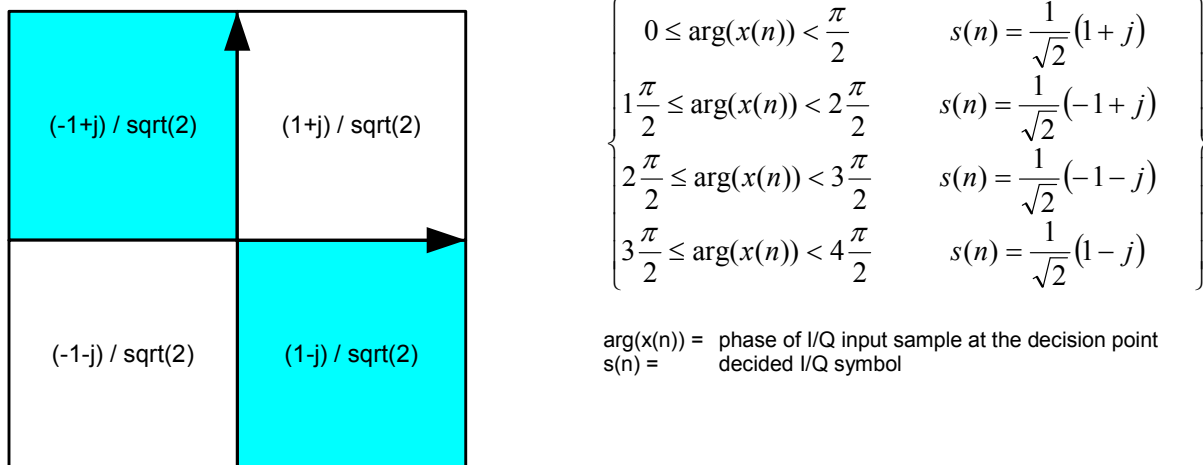

Fig. 88 QPSK segment decoder

The I/Q REF data record (signal 3b) is generated from the data record of the decided I/Q symbols after null stuffing (to attain the required oversampling rate) and filtering with the REFERENCE FILTER. After filtering with the MEASUREMENT FILTER, the measurement data record is forwarded as signal 3a to the subsequent processing stages. When MEASUREMENT FILTER = NONE is set, the data record is forwarded unchanged.

Phase ambiguity of demodulator

Up to now, the demodulator operated without knowing the transmitted signal. Since phase shifts may occur on the transmission path, the result of demodulation is ambiguous with respect to the phase position (because of the rotation symmetry in the PSK constellation). In the case of QPSK with static symbol mapping, this means that the I/Q measurement and I/Q reference signals as well as the decided symbols may have a constant phase offset of $\{0, \pi/2, \pi, \text{ or } 3\pi/2\}$. This offset can only be detected and eliminated in all 3 data records after sync pattern search in the data record.

If modulation types without static mapping are used, e.g. differential PSK or MSK, the information represented by the phase transition is encrypted so that static symbol mapping and the ambiguity of the starting phase are no longer a problem.

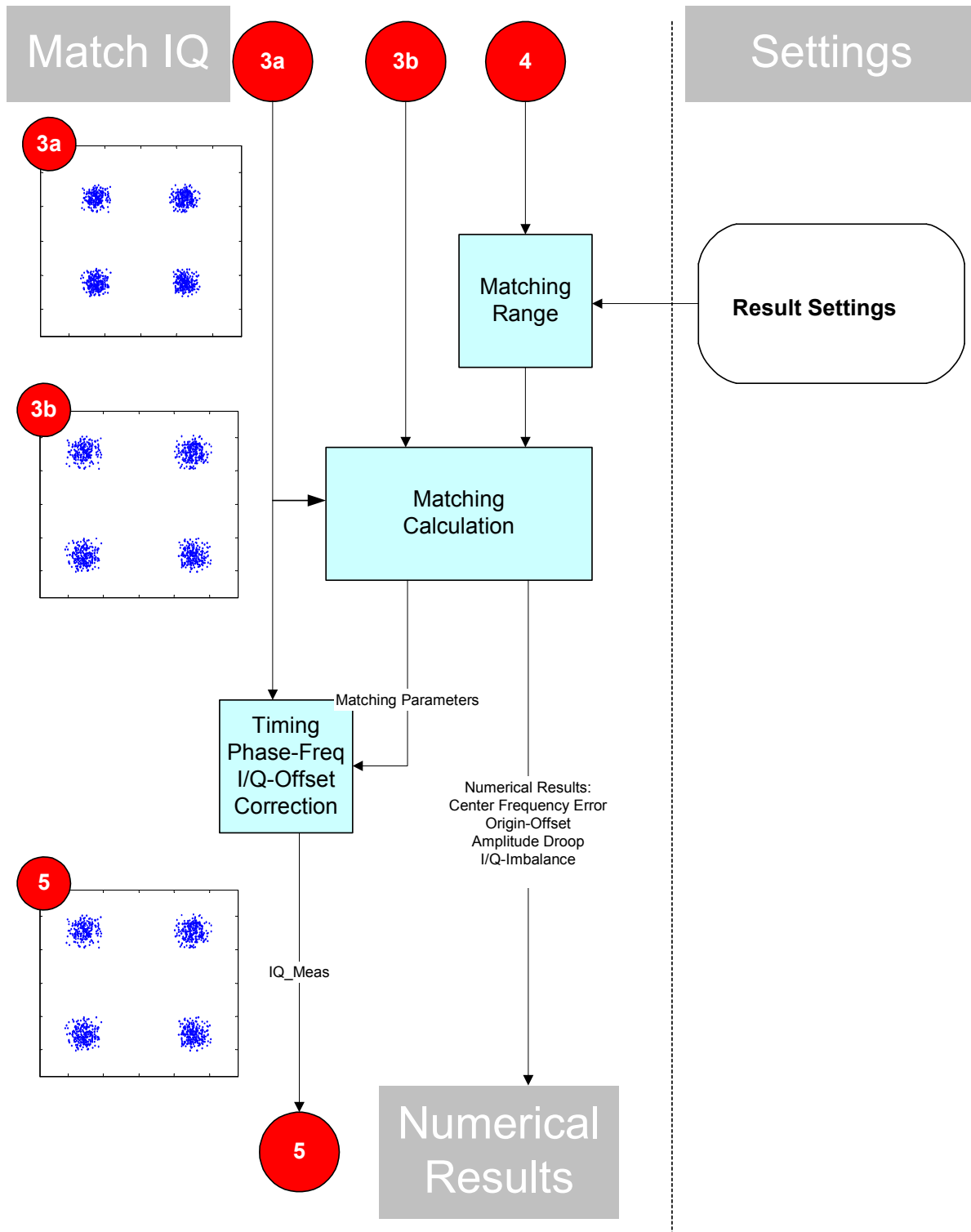

Fig. 89 Matching

Matching

The measurement signal was processed in the previous modulation stages so that error-free demodulation, symbol decision and reference signal generation could be performed.

In the **MATCHING** group, the error parameters (e.g. RMS EVM in case of PSK) are minimized.

With the aid of the following equation a transmit signal $Y(t)$ in the time domain can be obtained in the baseband (all parameters used are complex):

$$Y(t) = C1 \cdot (REF_{tx}(t) + ERR_{tx}(t) + C0) \cdot W;$$

where

- REF_{tx} is the ideal transmit signal,
- ERR_{tx} the error signal of the transmitter (linear and nonlinear distortions),
- C0 the I/Q offset (origin offset) and
- C1 a complex constant (phase and amplitude of transmitter).
- $W = e^{\alpha t + j\omega_0 t}$; is a complex factor which represents the amplitude variations in the burst (α) and a center frequency offset (ω_0).

The parameter to be minimized (valid for EDGE, for formulae of other modulation types see chapter 9 "[Glossary and Formulae](#)") is defined by

$$RMS_EVM = \sqrt{\frac{\sum_{n \in N} |EV(n)|^2}{\sum_{n \in N} |REF(n)|^2}};$$

containing the error vector $EV(n) = MEAS(n) - REF(n) - C0$;

where

- EV is the error vector after the prescribed measurement filtering,
- MEAS is the measured transmit signal (Y8t) after measurement filtering in the analyzer,
- REF is the reference signal and
- (n) the symbol points in the useful part (length N) of the demodulator range.

The RMS_EVM is minimized by means of a maximum likelihood function in the **MATCHING** block and the associated parameters (C0, C1, α ; ω_0) are determined.

During minimizing, a residual time offset τ_0 is also determined to compensate for the estimation uncertainty of the non-data-aided demodulator.

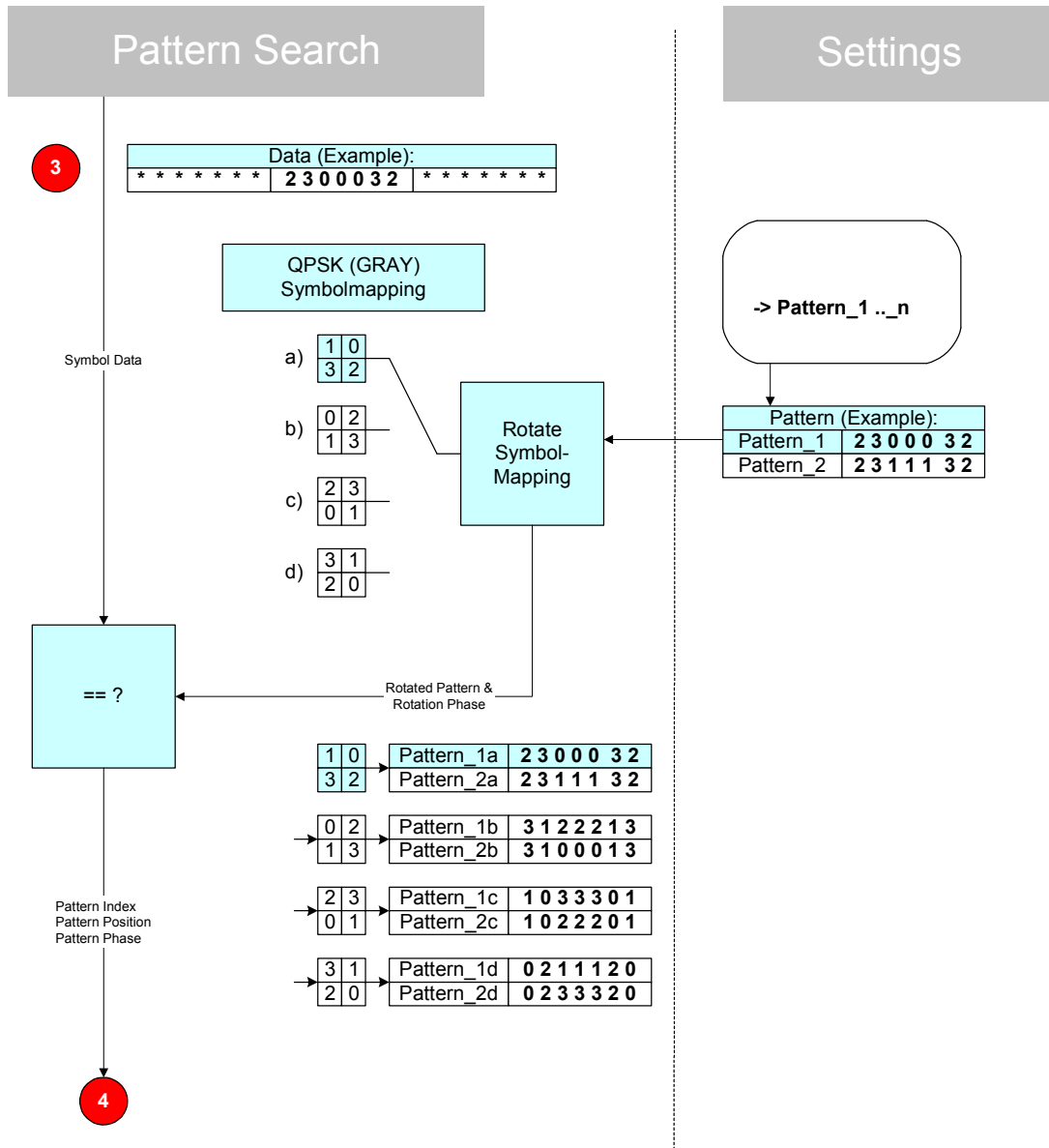

Fig. 90 Pattern search

Pattern Search

Many digital standards use constant symbol sequences (here called patterns) at defined positions in the burst, which are used in the mobile network for estimating transmission channel characteristics. In the analyzer, the pattern position defined by the standard is used for scaling and for determining the standard-specific measurement range.

In pattern search, a distinction is made between static mappings and differential mappings: With **static mappings**, the symbol information is represented by the absolute position of the symbol in the I/Q plane. Examples are QPSK, 8PSK and regular QAM constellations (see section "

Symbol Mapping"). Because of the rotation symmetry of these mappings, an unambiguous symbol decision is only possible after a pattern search.

When the pattern is found, the absolute phase position of the signal is also identified, the I/Q measurement data record and the I/Q reference data record are appropriately rotated and the symbol data record is corrected.

Fig. 90 illustrates the function principle for QPSK (GRAY mapping). The user predefines 2 possible sync patterns (Pattern_1 and Pattern_2). With QPSK, 4 symmetry states (mapping a to d) are possible, which correspond to a rotation of coordinates by 0, $\pi/2$, π , $3\pi/2$, respectively.

Original	<table border="1"> <tr><td>1</td><td>0</td></tr> <tr><td>3</td><td>2</td></tr> </table>	1	0	3	2	<table border="1"> <tr><td>Pattern_1a</td><td>2</td><td>3</td><td>0</td><td>0</td><td>3</td><td>2</td></tr> <tr><td>Pattern_2a</td><td>2</td><td>3</td><td>1</td><td>1</td><td>1</td><td>3</td><td>2</td></tr> </table>	Pattern_1a	2	3	0	0	3	2	Pattern_2a	2	3	1	1	1	3	2	
1	0																					
3	2																					
Pattern_1a	2	3	0	0	3	2																
Pattern_2a	2	3	1	1	1	3	2															

Hypotheses	Mapping	Temporary pattern	If pattern is found																				
Hypothesis a) (phase = $0\pi/2$)	<table border="1"> <tr><td>1</td><td>0</td></tr> <tr><td>3</td><td>2</td></tr> </table>	1	0	3	2	<table border="1"> <tr><td>Pattern_1a</td><td>2</td><td>3</td><td>0</td><td>0</td><td>3</td><td>2</td></tr> <tr><td>Pattern_2a</td><td>2</td><td>3</td><td>1</td><td>1</td><td>1</td><td>3</td><td>2</td></tr> </table>	Pattern_1a	2	3	0	0	3	2	Pattern_2a	2	3	1	1	1	3	2	<ul style="list-style-type: none"> - I/Q data records are unchanged - Symbol data record are unchanged 	
1	0																						
3	2																						
Pattern_1a	2	3	0	0	3	2																	
Pattern_2a	2	3	1	1	1	3	2																
Hypothesis b) (phase = $\pi/2$)	<table border="1"> <tr><td>0</td><td>2</td></tr> <tr><td>1</td><td>3</td></tr> </table>	0	2	1	3	<table border="1"> <tr><td>Pattern_1b</td><td>3</td><td>1</td><td>2</td><td>2</td><td>1</td><td>3</td></tr> <tr><td>Pattern_2b</td><td>3</td><td>1</td><td>0</td><td>0</td><td>1</td><td>3</td></tr> </table>	Pattern_1b	3	1	2	2	1	3	Pattern_2b	3	1	0	0	1	3	<ul style="list-style-type: none"> - I/Q data records are rotated clockwise by $\pi/2$ - The symbol data record is remapped (2->0, 0->1, 1->3, 3->2) 		
0	2																						
1	3																						
Pattern_1b	3	1	2	2	1	3																	
Pattern_2b	3	1	0	0	1	3																	
Hypothesis c) (phase = $2\pi/2$)	<table border="1"> <tr><td>2</td><td>3</td></tr> <tr><td>0</td><td>1</td></tr> </table>	2	3	0	1	<table border="1"> <tr><td>Pattern_1c</td><td>1</td><td>0</td><td>3</td><td>3</td><td>0</td><td>1</td></tr> <tr><td>Pattern_2c</td><td>1</td><td>0</td><td>2</td><td>2</td><td>0</td><td>1</td></tr> </table>	Pattern_1c	1	0	3	3	0	1	Pattern_2c	1	0	2	2	0	1	<ul style="list-style-type: none"> - I/Q data records are rotated clockwise by $2\pi/2$ - The symbol data record is remapped (3->0, 2->1, 0->3, 1->2) 		
2	3																						
0	1																						
Pattern_1c	1	0	3	3	0	1																	
Pattern_2c	1	0	2	2	0	1																	
Hypothesis c) (phase = $3\pi/2$)	<table border="1"> <tr><td>3</td><td>1</td></tr> <tr><td>2</td><td>0</td></tr> </table>	3	1	2	0	<table border="1"> <tr><td>Pattern_1d</td><td>0</td><td>2</td><td>1</td><td>1</td><td>1</td><td>2</td><td>0</td></tr> <tr><td>Pattern_2d</td><td>0</td><td>2</td><td>3</td><td>3</td><td>3</td><td>2</td><td>0</td></tr> </table>	Pattern_1d	0	2	1	1	1	2	0	Pattern_2d	0	2	3	3	3	2	0	<ul style="list-style-type: none"> - I/Q data records are rotated clockwise by $3\pi/2$ - The symbol data record is remapped (1->0, 3->1, 2->3, 0->2)
3	1																						
2	0																						
Pattern_1d	0	2	1	1	1	2	0																
Pattern_2d	0	2	3	3	3	2	0																

Fig. 91 Pattern search for static QPSK mapping

The algorithm internally converts the predefined pattern by taking the symmetry states into account (pattern 1a to d and pattern 2a to d) and searches in the symbol data record for this "rotating" search pattern. If the patterns exactly coincide, the search is successfully terminated and, if required, the I/Q data records and the symbol data record are corrected according to the hypothesis found.

With **differential** mappings, only a single-stage procedure is required because the symbol information is represented by the phase difference of two consecutive decision points. Correction of data records is therefore not required.

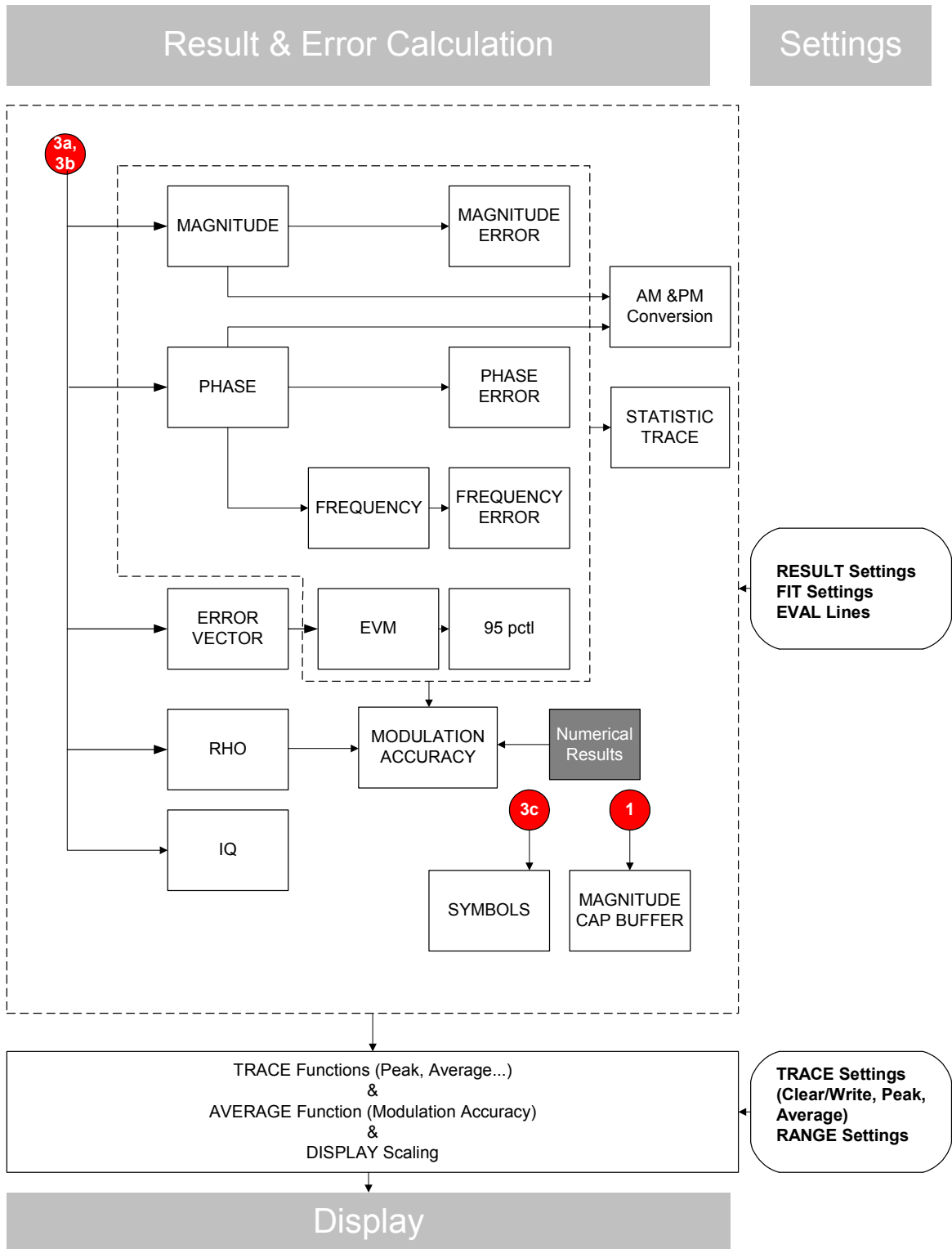

Fig. 92 Result & Error Calculation

Result & Error Calculation, Display

The result displays selected by the user are calculated and scaled in the two last processing stages.

Extreme values and average values over several measurements can be calculated for result display. This function can be switched on and off in the Trace menu.

The calculation formulae can be found in the description of the specific display modes and at the end of this manual (chapter 9, "*Glossary and Formulae*").

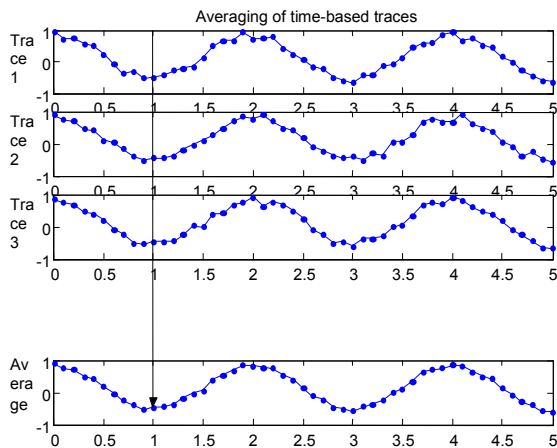

Fig. 93 Trace averaging

$$\left. \begin{array}{l} EVM(TRACE1) \\ EVM(TRACE2) \\ EVM(TRACE3) \end{array} \right\} \rightarrow RMS(EVM1..3);$$

Fig. 94 Averaging of scalar parameters

In the case of **trace display**, average and extreme values are calculated for each trace point derived from the measured value samples.

Fig. 93 illustrates this process of linear averaging over three measurements. The smoothed measurement trace (average) is also displayed.

For **numeric (scalar) result** display, the results of all single measurements are considered. Square averaging of the scalar EVM parameter is shown as an example. The linear average and the standard deviation are calculated for these measurement parameters in addition to the square average value.

Average and extreme value functions are not available for display in the I/Q plane.

Fig. 95 shows the different result displays that can be calculated from the I/Q measurement and I/Q reference data records (PSK, MSK, QAM).

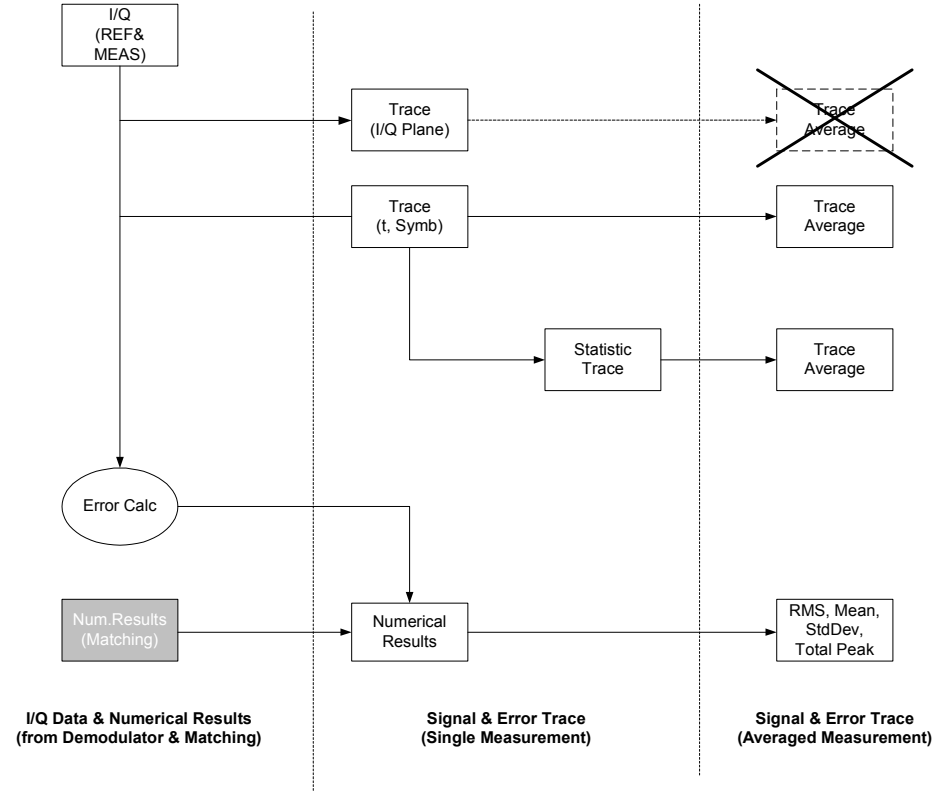

Fig. 95 Result display

Differences between Modulation Types

There are slight differences between the function blocks for QAM, VSB, MSK and FSK.

QAM

Processing is very similar to that of PSK, but evaluation of amplitude statistics and signal scaling are performed in the first processing stages. As with PSK, the optimization criterion for the MATCHING stage is the minimization of RSM EVM.

VSB

Processing is very similar to that of PSK, but evaluation of amplitude statistics and signal scaling are performed in the first processing stages (as with QAM). In addition the pilot carrier typical for VSB are removed from the signals. As with PSK, the optimization criterion for the MATCHING stage is the minimization of RSM EVM.

MSK

Demodulation and matching are based on I/Q data records; the optimization criterion for the MATCHING stage is the minimization of RMS phase errors. All available samples are used, not only the decision points.

FSK

Output data of the demodulator stage (and therefore the basis for all subsequent stages) comprises real data records with instantaneous frequencies. Optimization criterion for the MATCHING stage is the minimization of the RMS frequency error between reference and measurement signal.

Vector and Scalar Modulation Errors

Error Model of Transmitter

The following error model is used for the examples below:

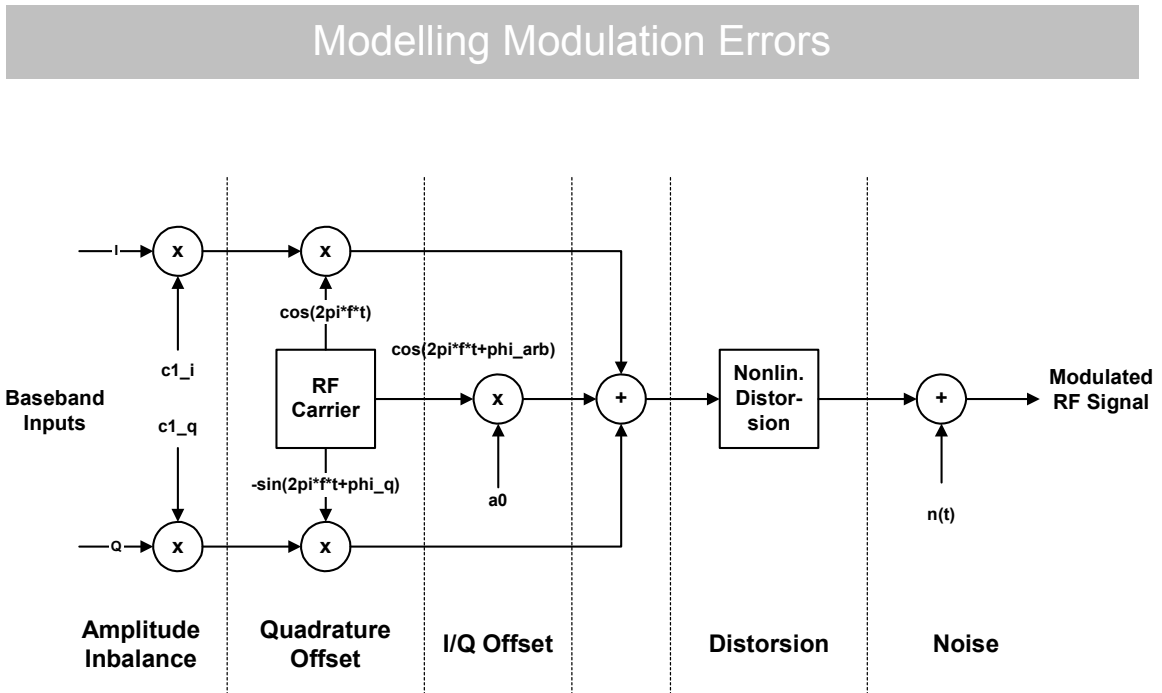
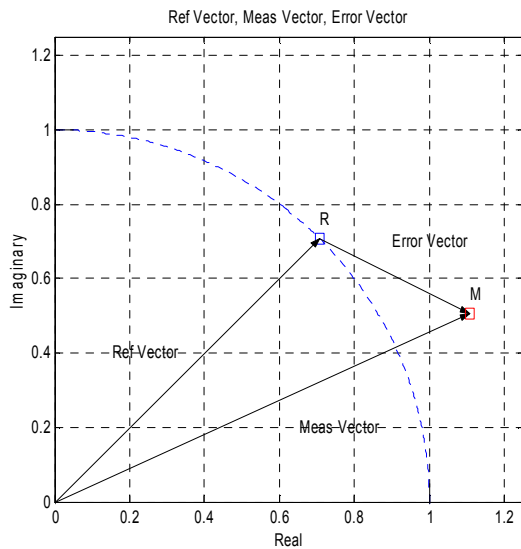

Fig. 96 Modulation error: error model of transmitter and transmission path

Modulation Error (PSK, MSK, QAM, VSB)

Error vector (EV)



Definition of error vector (EV):

The error vector is the difference between the measurement signal vector (Meas vector) and the reference signal vector (Ref vector).

Fig. 97 Modulation error: error vector

Error vector Magnitude (EVM)

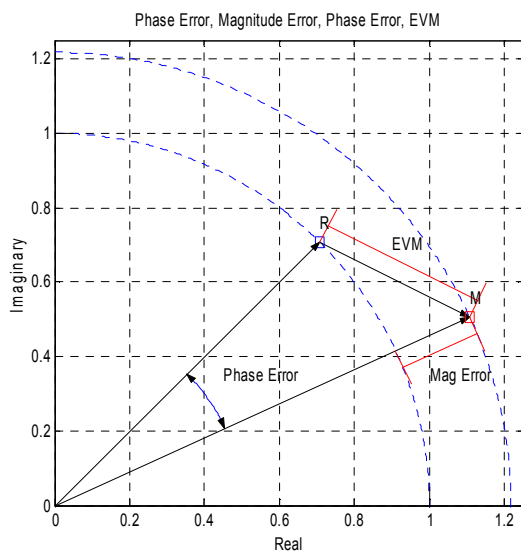

The error vector in the diagram is specified as error vector magnitude (EVM). The difference between the reference vector magnitude and the measurement vector magnitude is referred to as magnitude error.

In some modern networks, the basic EVM definition is modified so that the calculation is weighted with half the average signal power in the observed period. This is sometimes referred to as modulation error ratio (MER). In the case of ISI-free demodulation and measurements, the two definitions are identical.

Fig. 98 Modulation error: EVM, magnitude error

Phase error

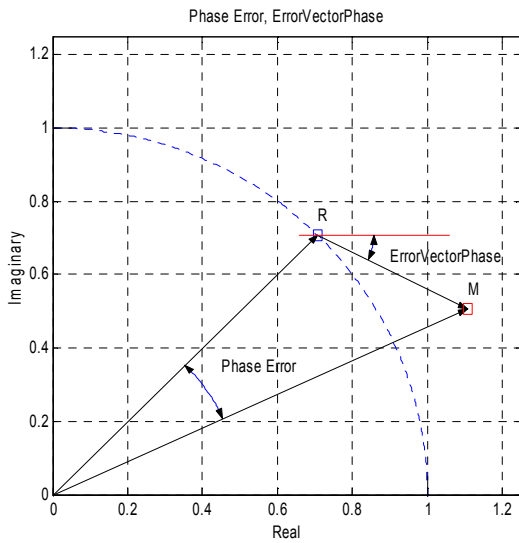

Fig. 99 illustrates the definition of the phase error: The phase error is the phase difference between the measurement vector and the reference vector.

$$\varphi_{err} = \arg(MEAS \cdot REF^*)$$

This measurement parameter is of great importance for MSK modulation measurements.

In contrast, the error vector phase is defined as:

$$\varphi_{EV} = \arg(EV);$$

Fig. 99 Modulation error: error vector phase, phase error

The effects of the different modulation errors in the transmitter on the result display of the analyzer are described on the next pages. All diagrams show the equivalent, complex baseband signal. Errors for FSK are shown in the frequency/time diagram.

IQ-Offset (Origin Offset)

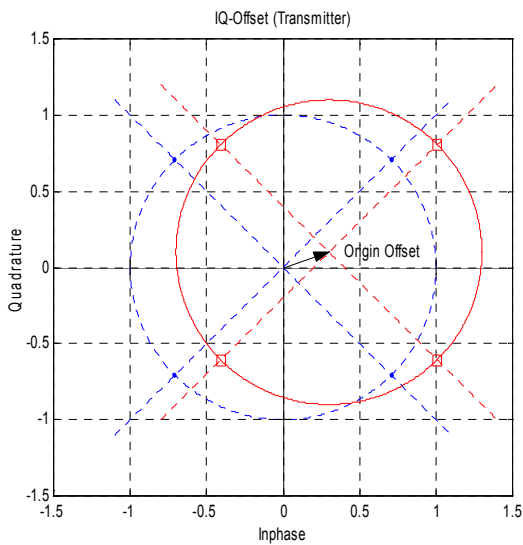

Fig. 100 Modulation error: origin offset (I/Q offset)

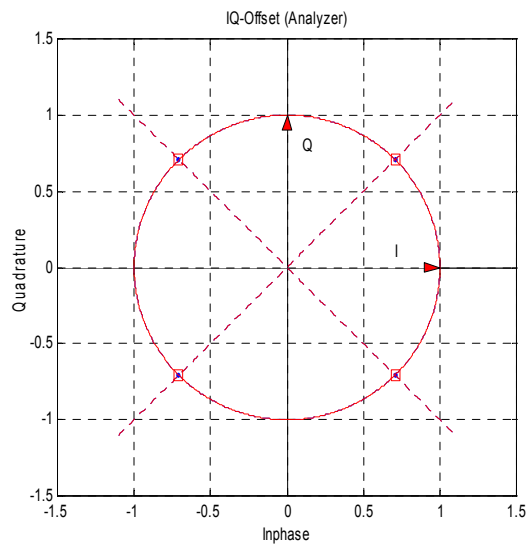

Fig. 101 Modulation error: compensation of origin offset

Fig. 100 and Fig. 101 show the effect of an I/Q offset or origin offset in the transmitter and in the analyzer after demodulation and error compensation.

The residual carrier of the amplitude C_0 and any phase is superimposed on the ideal transmit signal. The result is a noise vector in the complex baseband that shifts the constellation diagram out of its complex 0 position. Fig. 100 shows an ideal constellation diagram and a diagram shifted by the I/Q offset.

This error parameter is determined during demodulation and deducted from the complex measurement data record.

The result after error compensation is shown in Fig. 101. The ideal constellation diagram is restored after demodulation. The unit circle around the constellation points remains unchanged.

Gain Imbalance

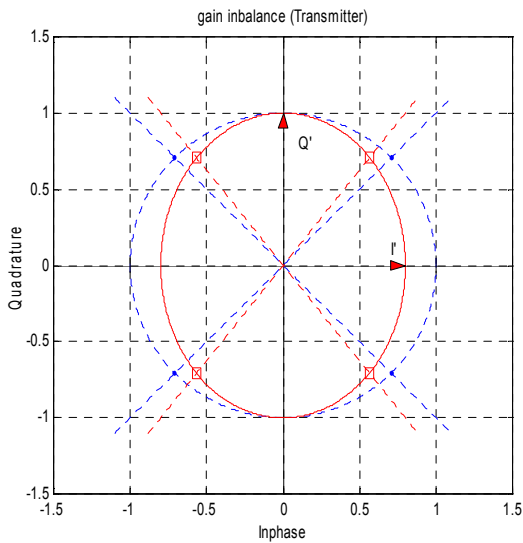

Fig. 102 Modulation error: gain imbalance (transmitter)

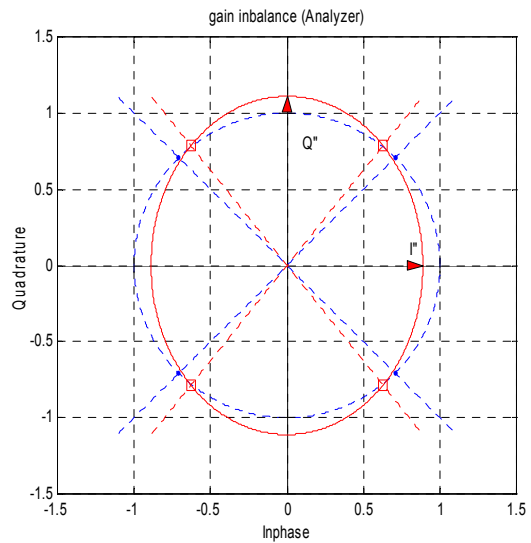

Fig. 103 Modulation error: gain imbalance (analyzer)

The gain difference in the I and Q channels during signal generation in the transmitter is referred to as gain imbalance. The effect of this error on the constellation diagram and the unit circle are shown in Fig. 102. In the example, the gain in the I channel is slightly reduced which causes a distortion of coordinates in the I direction. The unit circle of the ideal constellation points has an elliptic shape.

This distortion is not corrected in the analyzer. It increases the EVM and is part of the displayed I/Q imbalance error. Fig. 103 shows that the analyzer chooses linear scaling for the measurement signal to minimize the RMS EVM. The elliptic shape of the unit circle remains unchanged.

Quadrature Imbalance

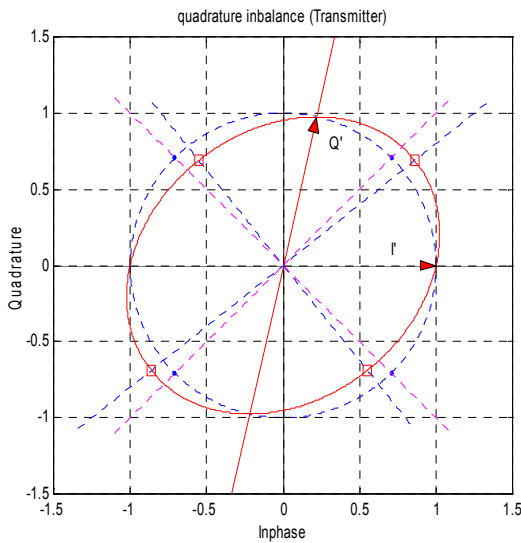

Fig. 104 Modulation error: quadrature imbalance (transmitter)

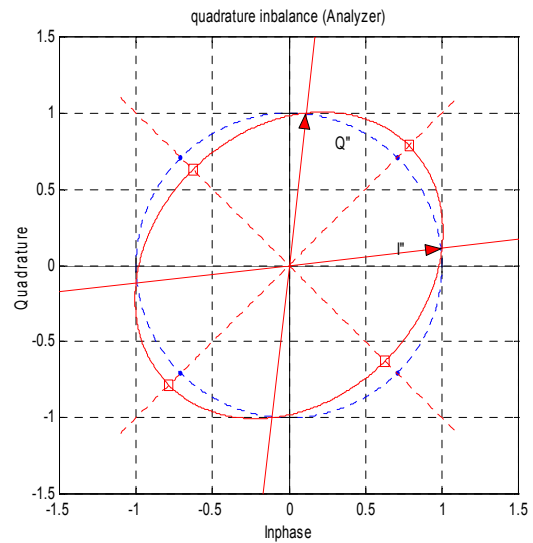

Fig. 105 Modulation error: quadrature imbalance (analyzer)

Quadrature imbalance is another modulation error which is shown in Fig. 104 and Fig. 105. In this diagram, the I and Q components of the modulated carrier are of identical amplitude but the phase between the two components deviates from 90°. This error also distorts the coordinates. In the example in Fig. 104 the Q axis is shifted. During demodulation in the analyzer, the phase is shifted in addition to linear amplitude scaling to minimize the RMS EVM. The elliptic shape of the unit circle remains unchanged.

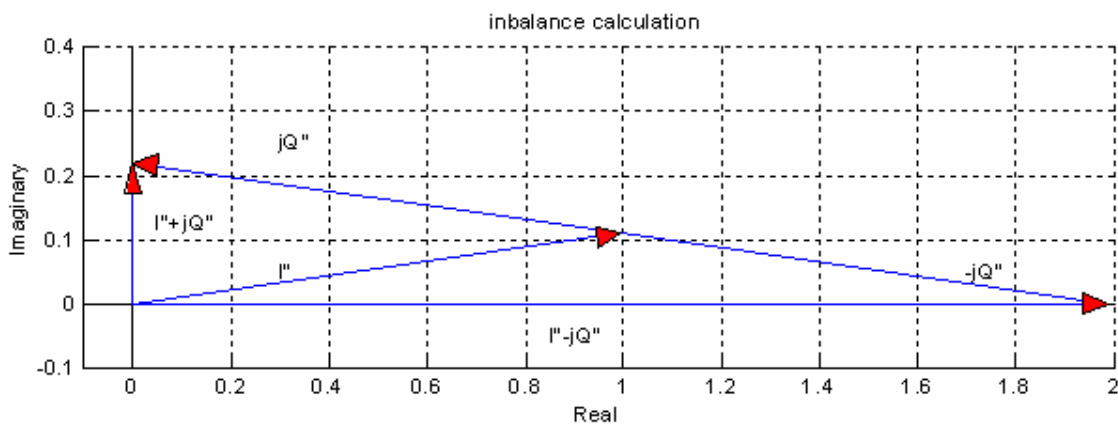

Fig. 106 Modulation error: I/Q imbalance

The effect of quadrature imbalance and gain imbalance are combined to form the error parameter I/Q imbalance.

$$IQ_Inbalance = \frac{2 * |I''+jQ''|}{|I''-jQ''|};$$

Fig. 106 shows this measurement parameter for the quadrature imbalance.

Gain Distortion

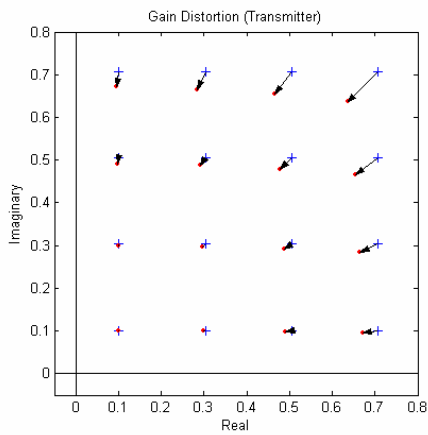

Fig. 107 Nonlinear distortions: amplitude distortion (transmitter)

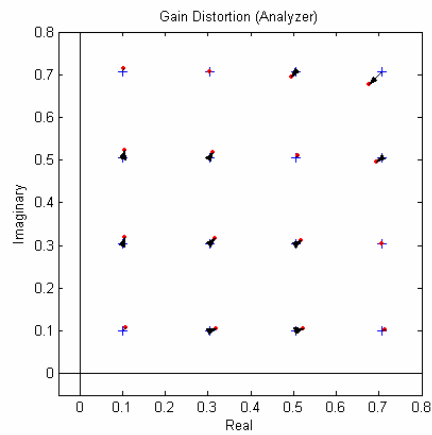

Fig. 108 Amplitude distortion (analyzer)

Fig. 107 illustrates the effect of nonlinear amplitude distortions on a 64QAM signal (only the 1st quadrant is shown). The transfer function is level-dependent: the highest effects occur at high input levels while low signal levels are hardly affected. The signal is scaled in the analyzer so that the average square magnitude of the error vector is minimized. Fig. 108 shows the signal after scaling.

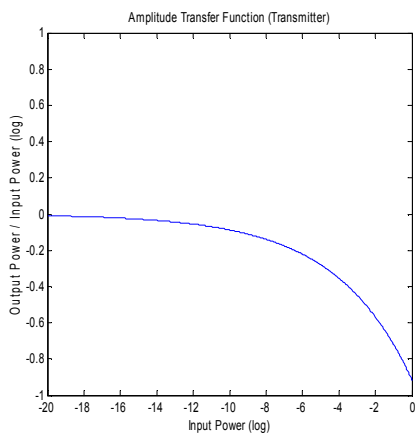

Fig. 109 Amplitude transfer function (transmitter)

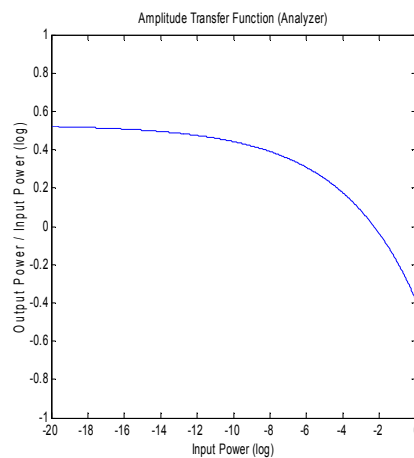

Fig. 110 Amplitude transfer function (analyzer)

Fig. 109 and Fig. 110 show a logarithmic display of the amplitude transfer functions. The analyzer trace is shifted against the transmitter trace by this scale factor.

Phase Distortion

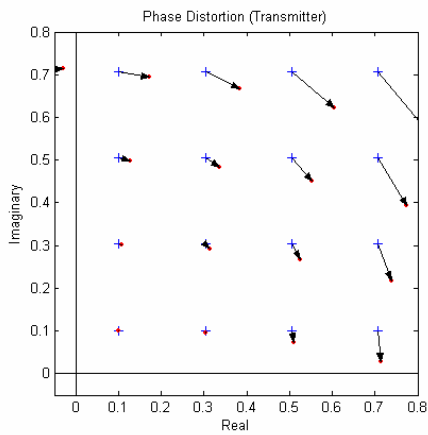

Fig. 111 Nonlinear distortions: phase distortion (transmitter)

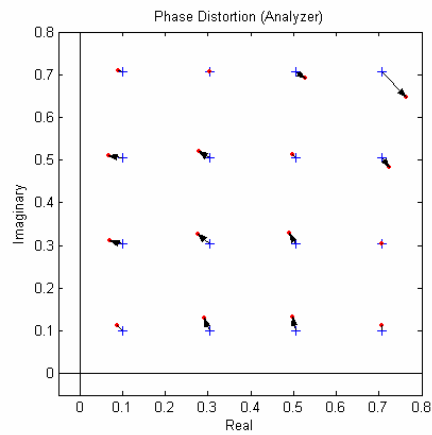

Fig. 112 Phase distortion (analyzer)

Fig. 111 illustrates the effect of nonlinear phase distortions on a 64QAM signal (only the 1st quadrant is shown). The transfer function is level-dependent: the highest effects occur at high input levels while low signal levels are hardly affected. These effects are caused, for instance, by saturation in the transmitter output stages. The signal is scaled in the analyzer so that the average square magnitude of the error vector is minimized. Fig. 112 shows the signal after scaling.

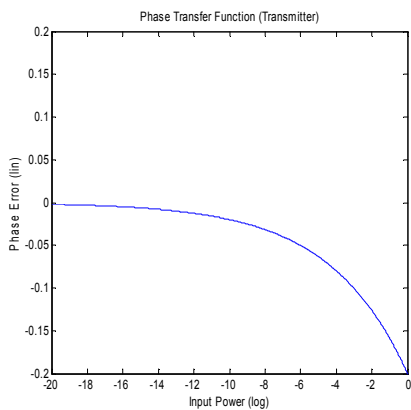

Fig. 113 Nonlinear distortions: phase distortion (transmitter)

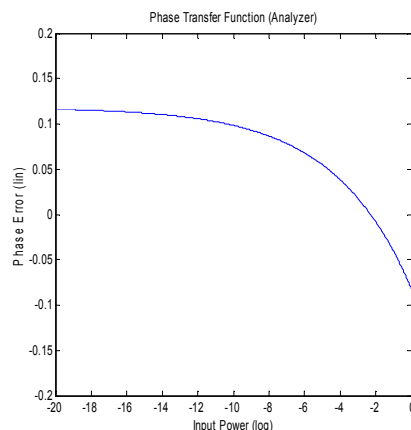

Fig. 114 Phase distortions (analyzer)

Fig. 113 and Fig. 114 show a logarithmic display of the phase transfer functions. The analyzer trace is shifted by the phase described above as against the transmitter trace.

Noise

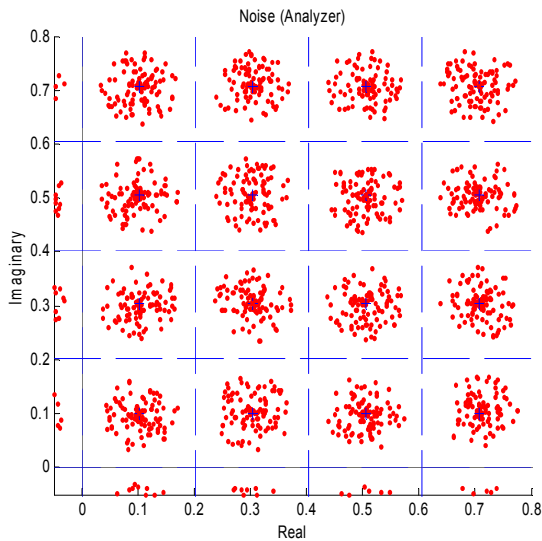

Fig. 115 Additive noise

Fig. 115 shows a 64QAM signal (only the 1st quadrant is shown) with **additive noise**. The symbol decision thresholds are also shown.

The noise signal forms a "cloud" around the ideal symbol point in the constellation diagram. Exceeding the symbol decision boundaries leads to wrong symbol decisions and increases the bit error rate.

Similar displays are obtained in case of **incorrect filter settings** (transmitter filter or corresponding receive filter in the analyzer). When an incorrect filter is selected, crosstalk occurs between neighbouring symbol decision points instead of the ISI-free points. The effect increases the more the filtering deviates from actual requirements.

The two effects described cannot be distinguished in the I/Q constellation diagram but in statistical and spectral analyses of the error signal.

Modulation Error (FSK)

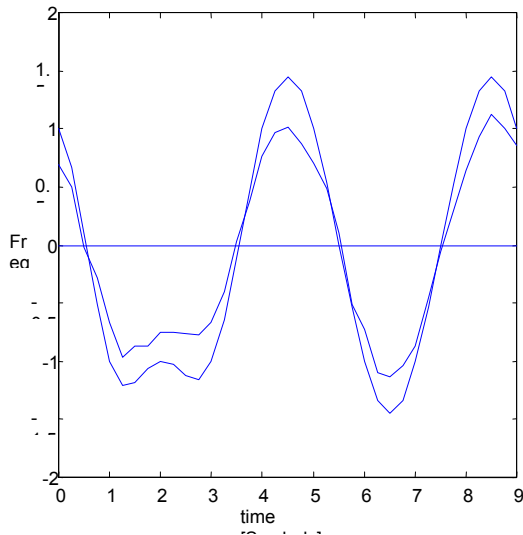

Fig. 116 Modulation error: reference signal (REFDEVCOMP = OFF) and measurement signal

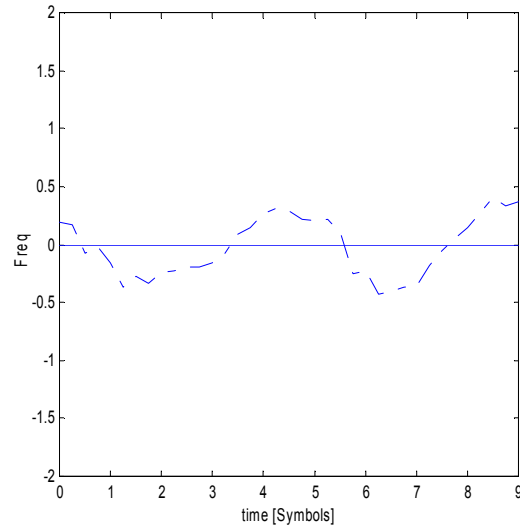

Fig. 117 Modulation error: frequency error, reference signal not normalized

Fig. 116 shows the instantaneous frequency characteristic of the MEAS signal and the REF signal characteristic.

The FSK demodulator demodulates the signal down to symbol level and generates the REF signal using the transmitter filter and the reference deviation set.

A center frequency error is automatically compensated for during demodulation (as with PSK, MSK and QAM) and has no effect on subsequent error calculations.

The following error parameters are calculated by correlation or simply by forming the difference:

- Deviation error = numeric value for the entire measurement range
- Frequency error = deviation from the instantaneous frequency of the two signals

Fig. 117 shows the frequency error calculated from the MEAS and REF signals in Fig. 116. A striking feature is the modulation-dependent error signal variations.

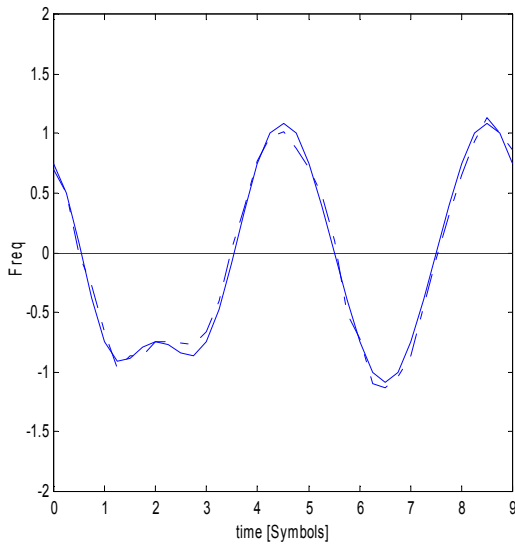

Fig. 118 Modulation error: reference signal normalized

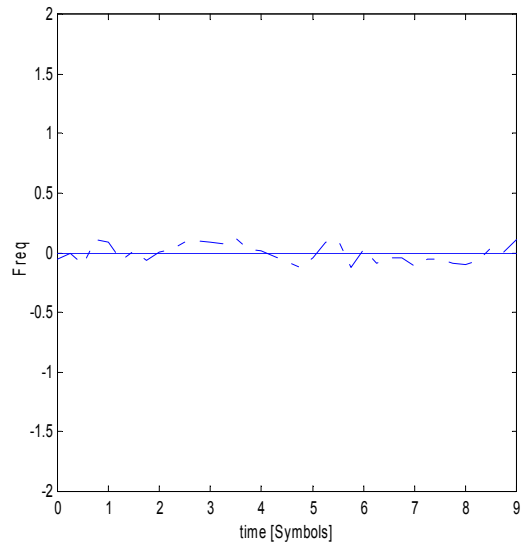

Fig. 119 Modulation error: frequency error, reference signal normalized

With FERDEVCOMP ON, the **reference signal is scaled** so that the RMS error between the scaled REF signal and the MEAS signal is minimized.

Fig. 118 shows the same MEAS signal as Fig. 119 and a REF signal with rescaled reference deviation. The error plot (Fig. 119) no longer shows modulation-dependent variations; the errors are statistically distributed around the 0 frequency.

4 Operation and Menu Overview

Operation

The R&S FSQ-K70/FSMR-B73/FSU-B73 option is menu-guided using keys, hotkeys and softkeys.

Special Features/Differences from the Basic Instrument

The standard unit is symbols.

In some cases (e.g. RECORD LENGTH), time can be selected as the basic unit. If so, the values are automatically rounded up to the next integer that expresses the number of symbols.

Display of States Within Softkeys

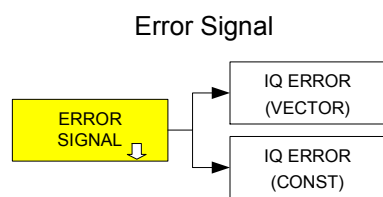

For softkeys that offer more than one setting, the softkey labelling indicates the current setting. For example, the following settings are possible for the measurement evaluation IQ Error:

- IQ ERROR VECTOR Display of I/Q error in the vector diagram
- IQ ERROR CONST Display of I/Q error in the constellation diagram

The state of the softkey is indicated by its color:

- The measurement is switched off:
The softkey is grey

	<ul style="list-style-type: none"> - The measurement is switched on with the display mode VECTOR. The softkey is highlighted in green, the setting VECTOR is indicated in brackets.
	<ul style="list-style-type: none"> - The measurement is switched on with the display mode CONSTELLATION The softkey is highlighted in green, the setting CONST is indicated in brackets.

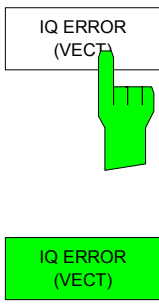
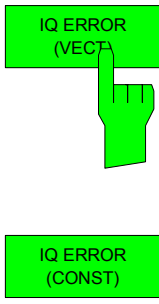
	<p>- Pressing the inactive softkey re-activates the measurement set last and the softkey colour changes from grey to green.</p>
	<p>- Pressing the active softkey open the window for selecting the softkey setting.</p>

Display of Setting Parameters Within Softkeys

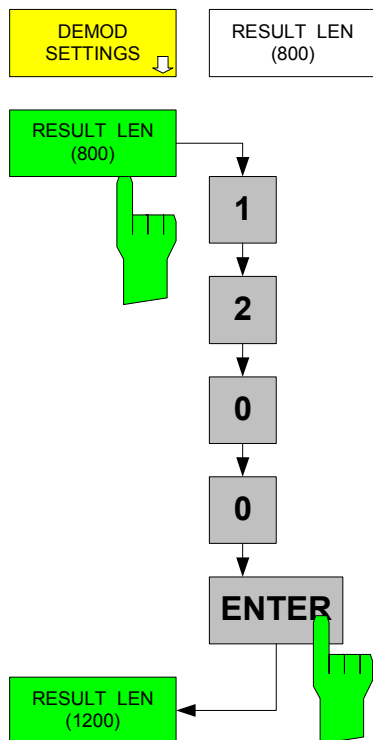

The current set value of some numeric entry parameters is displayed in the softkey labelling.

Examples:

RECORD LENGTH LENGTH (with unit)
 RESULT LENGTH (without unit; SYMBOLS is used as the standard unit here)

The current set value can thus be immediately read off without opening the associated softkey menu. The selected unit is also displayed in the labelling of softkeys that enable parameters to be entered with different basic units (e.g. TIME or SYMBOLS).

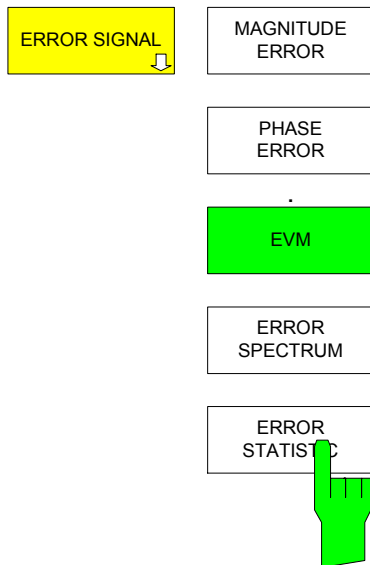

The *ERROR STATISTIC* and *ERROR SPECTRUM* softkeys offer additional evaluation modes:

When the *ERROR STATISTIC* softkey is selected, not the error parameter itself but its statistical distribution is output in the selected display mode (e.g. EVM).

When the *ERROR SPECTRUM* softkey is selected, a fast Fourier transform (FFT) for determining the spectrum is carried out for the selected type of display (e.g. EVM).

The basic display mode is restored by again pressing (switching off) the *ERROR STATISTIC* or the *ERROR SPECTRUM* softkey.

When a new display mode is activated (e.g. *MAGNITUDE ERROR*, *PHASE ERROR*), the *ERROR STATISTIC* and *ERROR SPECTRUM* softkeys are automatically switched off.

Suitable evaluation modes are available for the record buffer and the measurement and reference signal (see section "*Display of Measurement Results*").

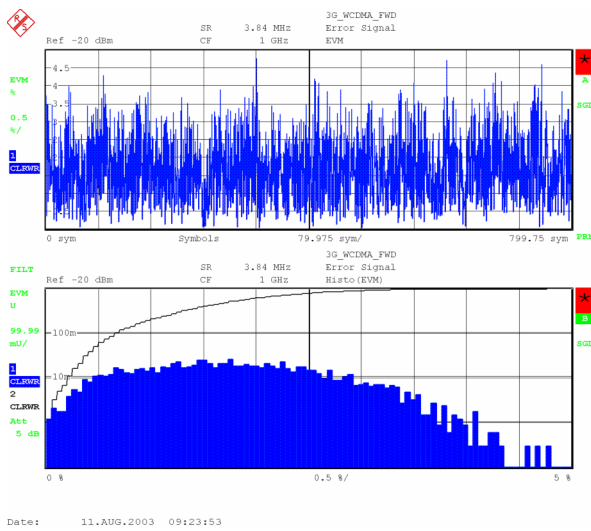

Fig. 120 Result display split screen
EVM (upper diagram)
ERROR STATISTIC + *EVM* (lower diagram)

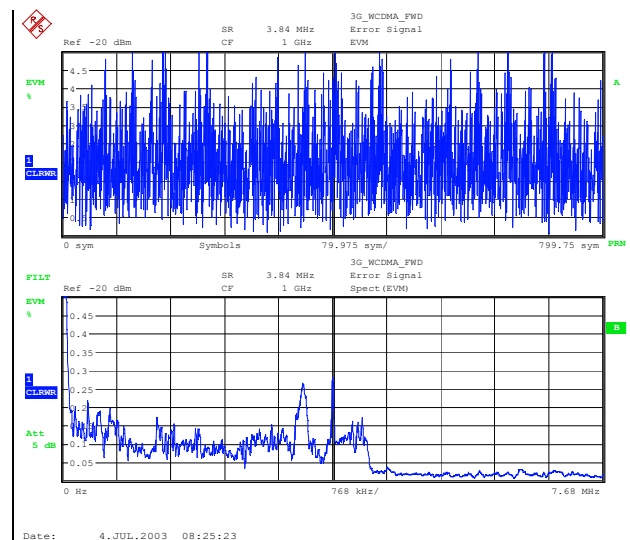

Fig. 121 Result display split screen
EVM (upper diagram)
ERROR SPECTRUM + *EVM* (lower diagram)

STATISTIC: The unit and the scaling of the y-axis of the basic diagram is also used for the x-axis of the statistic diagram.

SPECTRUM: The unit and the scaling of the y-axis of the basic diagram is also used for the y-axis of the spectrum diagram. The scaling of the x-axis depends on the I/Q bandwidth.

Measurement Window

The measurement window configuration is only slightly different from that of the basic instrument. Information on vector signal analysis has replaced the displays that are typical for the spectrum analyzer mode such as filter settings and sweep time (RBW, VBW, SWT). For displays of the measurement window that are not described here, refer to the documentation for the basic instrument.

The new fields **above the measurement curve** are provided to display the following:
 Digital standard or modulation mode
 Symbol rate
 Designation of the result display

The following status information is displayed **in the curve**:
 Warnings and status information on the current measurement (e.g. BURST NOT FOUND)
 Consecutive number and number of measurements for averaging measurements

Additional information on the type of filtering in signal processing is provided **to the left of the curve**:
 RAW or FILT for measurements on non-filtered or measurement-filtered signals

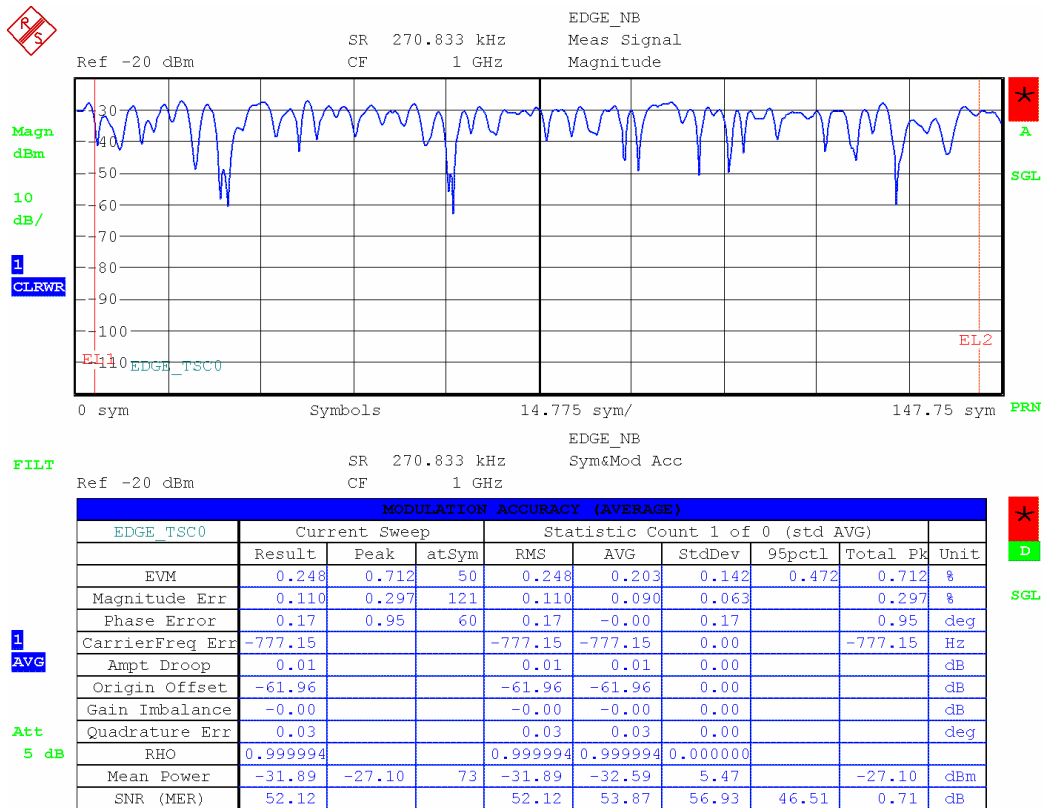

Date: 11.AUG.2003 09:55:15

Fig. 122 Measurement window of the R&S FSQ-K70/FSMR-B73/FSU-B73 option

Warnings and Messages of Signal Processing Stages

Depending on the type of input signal, various errors may occur during demodulation.

BURST NOT FOUND

The analyzer was parameterized with BURST SRCH ON (search for bursts = ON) but no burst was found in the signal.

PATTERN NOT FOUND .

The analyzer was parameterized with PAT SRCH ON (search for patterns = ON) but no set synchronization pattern was found.

- **END OF BUFFER**

The analyzer has reached the end of the captured data record. No more data for demodulation and measurement is present. This message occurs only if multiple evaluation mode (MULTI) as well as SINGLE SWEEP are active and no new data is captured automatically (AUTO CAPTURE = OFF).

- **NO VALID SIGNAL**

The analyzer cannot demodulate the input signal. This message may occur if noise, an unmodulated carrier, or a signal with noncompliant modulation parameters is present at the input.

In the signal and modulation error traces, such measurements are marked with a warning on the function panel. If several warnings occur at the same time, only the warning with the highest priority is displayed on this panel and further ones are suppressed.

Table 9 Warnings displayed in the order of priority

Priority	Warning	Cause	Message suppressed in the presence of a warning with a higher priority
Very High	NO VALID SIGNAL	Demodulation not possible	
High	END OF BUFFER	End of the recorded data set reached	
Medium	BURST NOT FOUND	No burst in the signal, but BURST SRCH ON	
Low	PATTERN NOT FOUND	No pattern in the signal, but PAT SRCH ON	BURST NOT FOUND

With an error-free measurement, the name of the pattern found (e.g. GSM_TSC0) is displayed on this function panel. If a pattern search is not active, the panel remains blank.

Discarding a Measurement

With MEAS ONLY ON BURST and MEAS ONLY ON PATT, the analyzer only performs and displays measurements with a valid burst signal or pattern. Otherwise, both measurement is suppressed and status Message SEARCHING BURST or SEARCHING PATTTER is indicated on the display. For averaged measurements with the setting BURST SRCH=ON, MEAS ONLY ON BURST should also be activated so that erroneous measurements do not affect the result of averaging. The same applies to pattern searches.

Menu Overview

Hotkeys

Assignment of the Hotkey Bar of the Basic Instrument

The position of the VSA hotkey varies depending on the type and number of installed options.

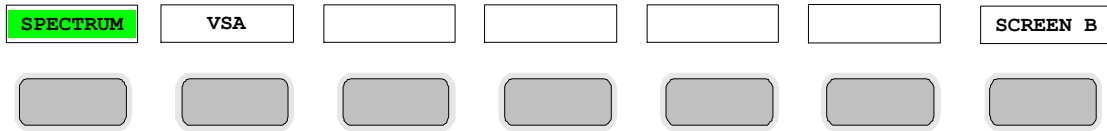

Fig. 123 Hotkey bar of the basic instrument with the R&S FSQ-K70/FSMR-B73/FSU-B73 option installed

Assignment of the Hotkey Bar of the Option

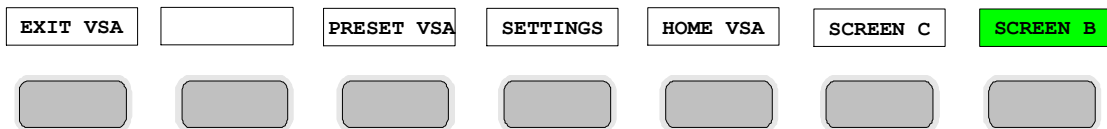
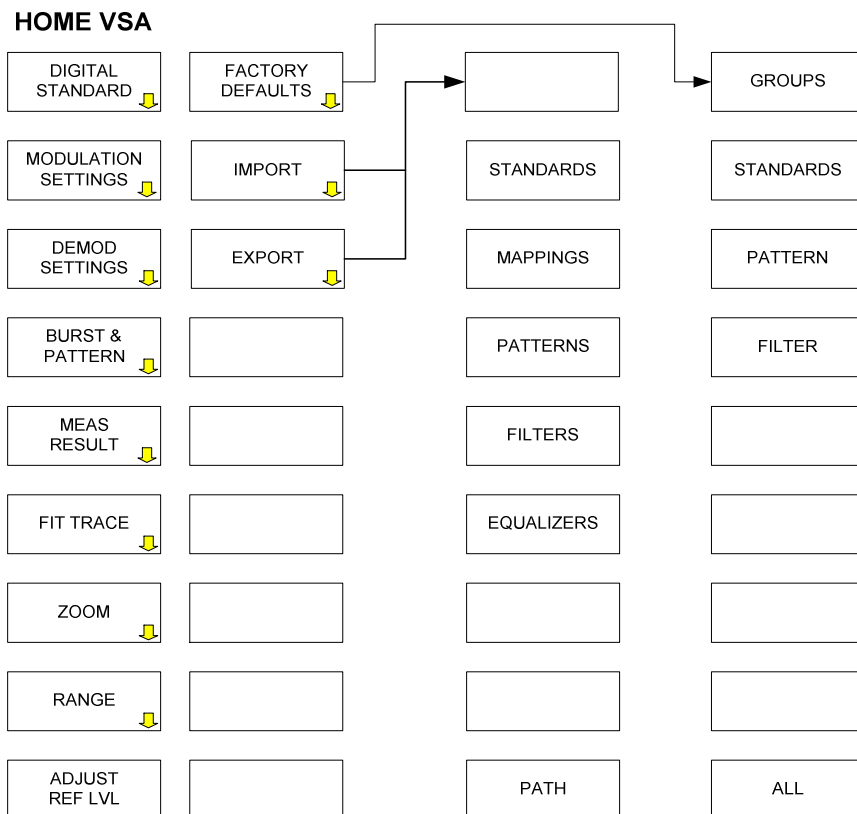
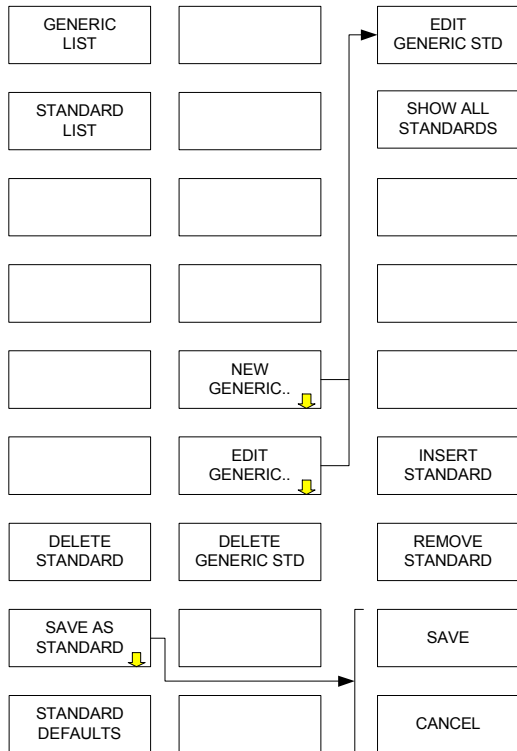

Fig. 124 Hotkey bar with the R&S FSQ-K70/FSMR-B73/FSU-B73 option switched on

Softkeys



Digital Standard



Meas Result

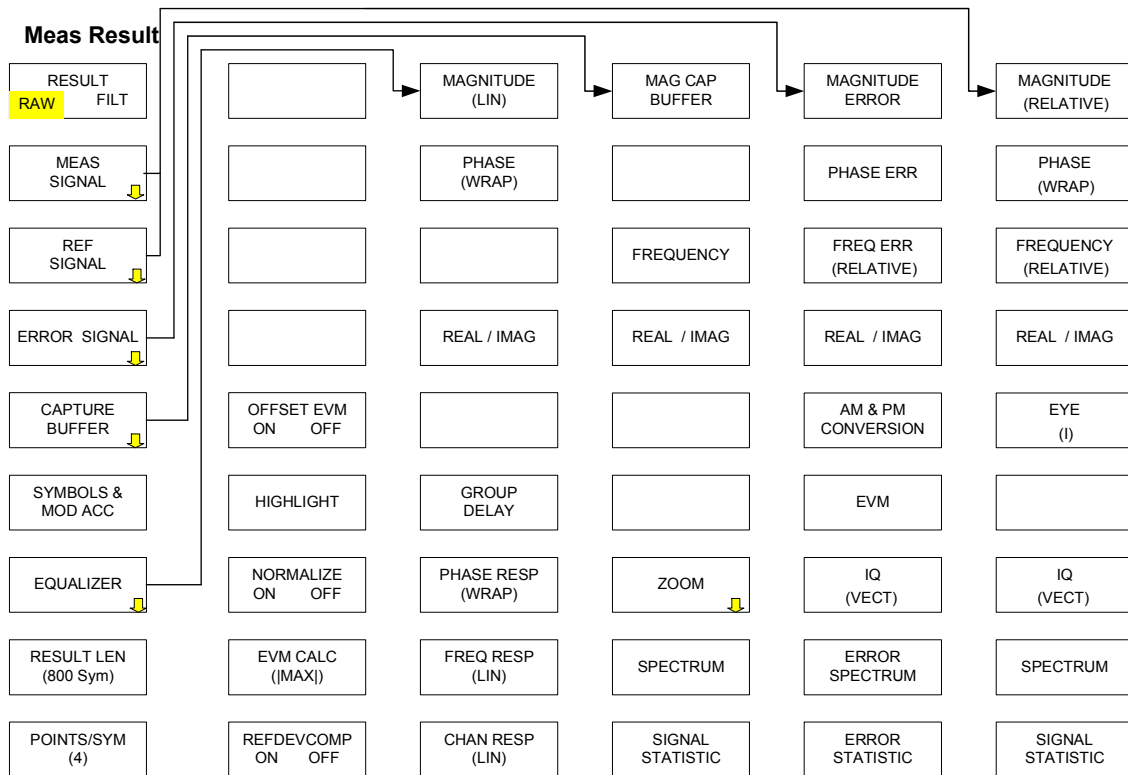

Fit Trace

	RECORD LEN AUTO
FIT TRIGGER	RECORD LEN (800 SYM)
FIT BURST	RECORD LEN (1.579 us)
FIT PATTERN	
FIT ALIGN LEFT	
FIT ALIGN CENTER	PAT POS (123SYM)
FIT ALIGN RIGHT	
FIT ALIGN (20%)	RESULT LEN (456SYM)
SET SYMB # (58SYM)	FIT OFFSET (-10SYM)

ZOOM

ZOOM START
ZOOM LENGTH
DEMOD NEXT RIGHT
DEMOD RESTART
DEMOD @ ZOOM START
CAPTURE AUTO OFF
MULTI ON OFF

Modulation Settings

SYM RATE (270.833 kHz)	
MODULATION & MAPPING	
MODULATION FILTER	MODULATION FILTER
EQUALIZER SETTINGS	
	NEW USER SET
ALPHA / BT (0.3)	DELETE USR SET
FSK DEV (123.4 kHz)	SAVE USER SET
POINTS/SYM (4)	

EQUALIZER ON OFF
EQUALIZER TRAIN
EQUALIZER FREEZE
EQUALIZER RESET
EQUALIZER LENGTH
EQUALIZER STEP
EQUALIZER LOAD
EQUALIZER SAVE
EQUALIZER DELETE

Demod Settings

RECORD LEN (8 kSym)	EVAL LINE 1	AUTO
RESULT LEN (800)	EVAL LINE 2	RECORD LEN (8 kSym)
EVAL LINES		RECORD LEN (1.234 ms)
MULTI ON OFF		
FORCE WB PATH		
SIDEBAND NORM INV		
NORMALIZE ON OFF		
POINTS/SYM (4)		

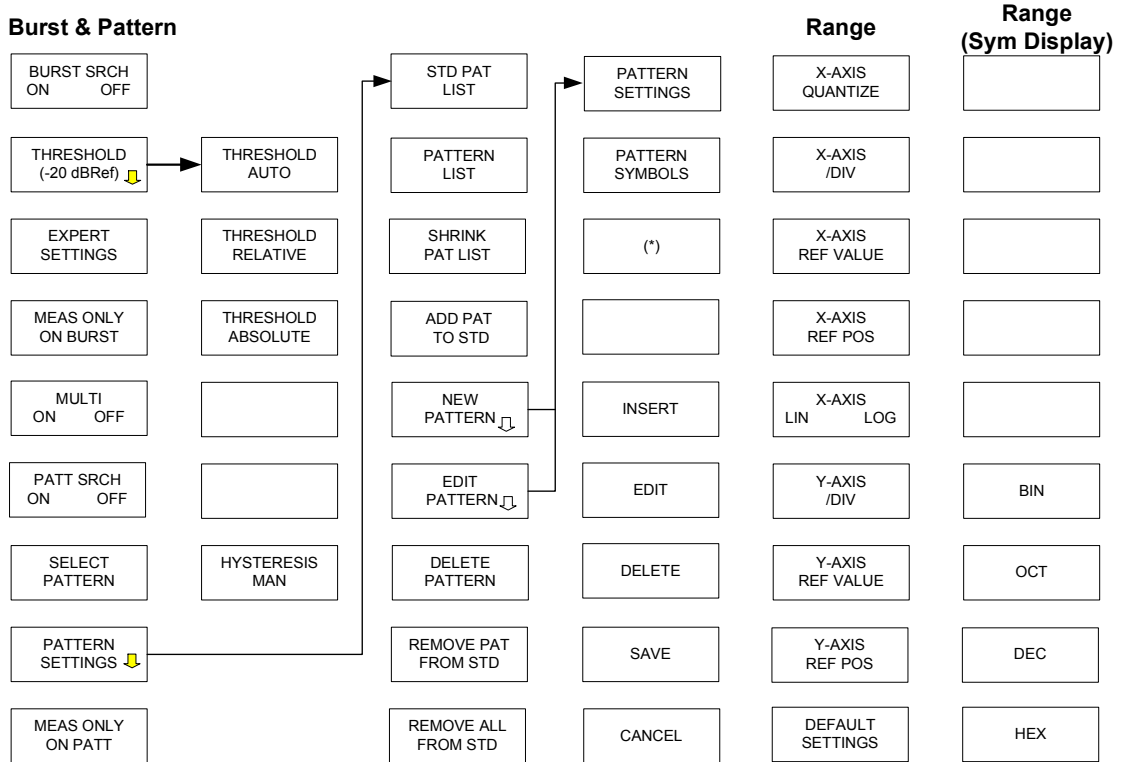

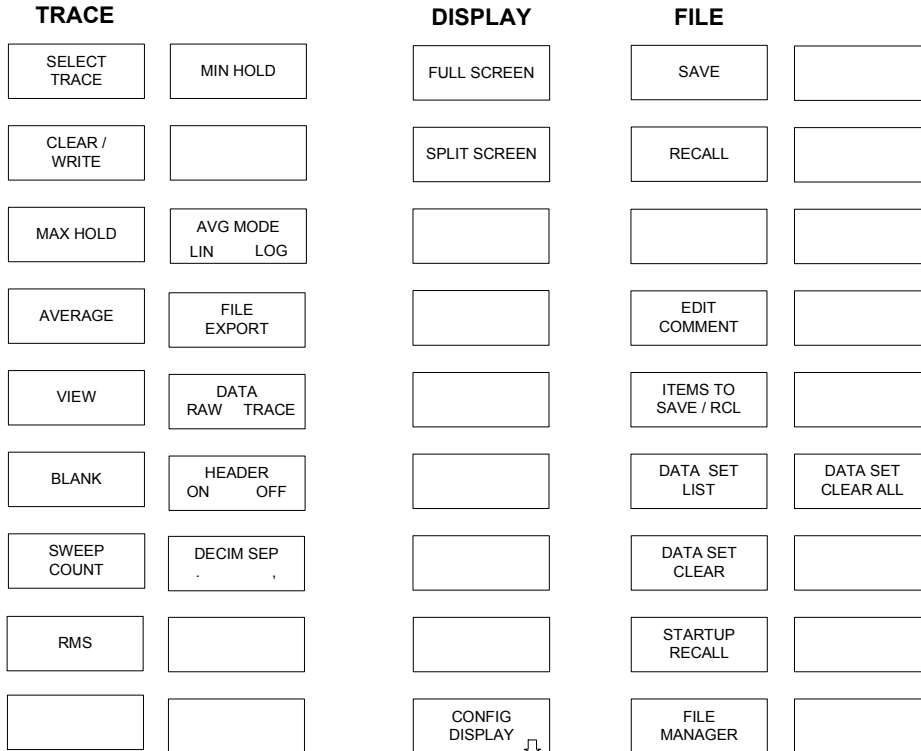
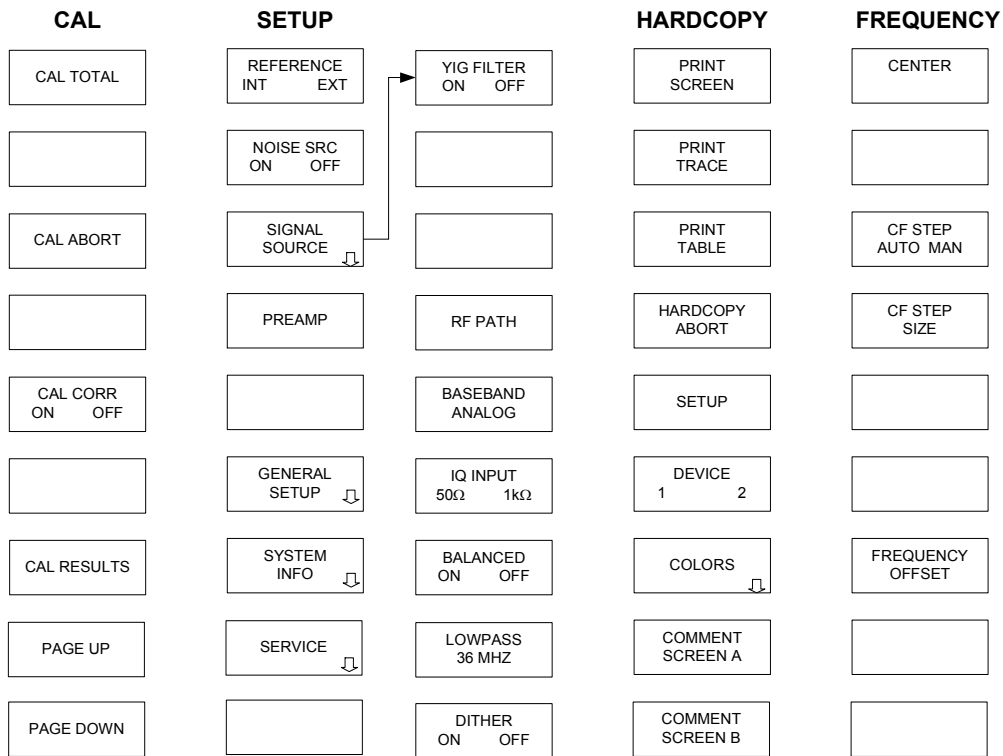

AMPT			BW	SWEEP	TRIGGER
REF LEVEL			RES BW MANUAL	CONTINUOUS SWEEP	FREE RUN
	REF LEVEL OFFSET		RES BW AUTO	SINGLE SWEEP	
		Y UNIT LOG DB		DEMOD NEXT RIGHT	EXTERN
RANGE		Y UNIT LINEAR		DEMOD RESTART	IF POWER
DISPLAY UNIT		Y UNIT DEG		DEMOD @ ZOOM START	IQ LEVEL
RF INPUT AC DC		Y UNIT RAD		SWEEP COUNT	TRIGGER OFFSET
RF ATTEN MANUAL				CAPTURE AUTO OFF	POLARITY POS NEG
RF ATTEN AUTO		X UNIT TIME		MULTI ON OFF	MEAS ONLY ON PATT
ADJUST REF LVL	MIXER	X UNIT SYMBOL			MEAS ONLY ON BURST
MARKER			MKR ->	MKR FCT	LINES
MARKER 1	MKR -> TRACE		SELECT MARKER	COMP PT (1 dB)	SELECT LIMIT LINES
MARKER 2			MAX PEAK		NEW LIMIT LINE
MARKER 3			MIN PEAK		EDIT LIMIT LINE
MARKER 4			MAX PEAK		COPY LIMIT LINE
MARKER NORM DELTA					DELETE LIMIT LINE
					X OFFSET
					Y OFFSET
ALL MARKER OFF			MKR -> TRACE		

5 Instrument Settings and Measurements

Resetting the Option - PRESET VSA Hotkey

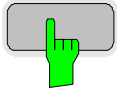

The *PRESET VSA* hotkey resets the R&S FSQ-K70/FSMR-B73/FSU-B73 option to the initial state (3G_WCDMA_FWD).

The settings of other applications such as frequency, level and trigger values remain unchanged.

IEC/IEEE bus command - (IEC/IEEE bus command *RST resets all instrument settings in contrast to the hotkey.)

Overview of Current Settings - SETTINGS Hotkey

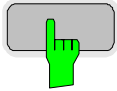

The *SETTINGS* hotkey opens a table containing the most important settings of the option (see Fig. 125). The window provides an overview but it cannot be used to set parameters.

IEC/IEEE bus command-

USA SETTINGS			
DIGITAL STANDARD	DECT_FP	INSTR SETTINGS	
MOD SETTINGS		Input	RF
Symbol Rate	1.152 MHz	Center Frequency	1 GHz
Modulation	2FSK	Reference Level	-20 dBm
Mapping	NATURAL	RF Attenuator	AUTO
Transmit Filter	GAUSS	Sweep	continuous
Receive Filter	NONE	Trigger	free run
Weighting Filter	NONE	Trigger Offset	0 s
BURST & PATTERN	SETTINGS	RESULT SETTINGS	
Burst Search	ON	Sweep Count	0
Burst Threshold	AUTO	Fit	pattern to left
Pattern Search	ON	Fit Offset	-4 Symbols
Pattern	DECT_FP,...	SCREEN A/C	A
Meas Only	all	Range X	-4 to 419.75 Symb
DEMOD SETTINGS		Range Y	-0.15 to 0.15 U
Record Length	12000 Symbols	Trace 1	Frequ CLRWR
Result Length	424 Symbols	Trace 2	-
Eval Size	0 419 Symbols	Trace 3	-
Sideband	NORM	SCREEN B/D	B
Points / Symbol	4	Range X	-
		Range Y	B
		Trace 1	-
		Trace 2	-
		Trace 3	-

Fig. 125 Overview of vector analysis settings

Configuration of Measurements - HOME VSA Hotkey

The measurement is configured in the *HOME VSA* menu:

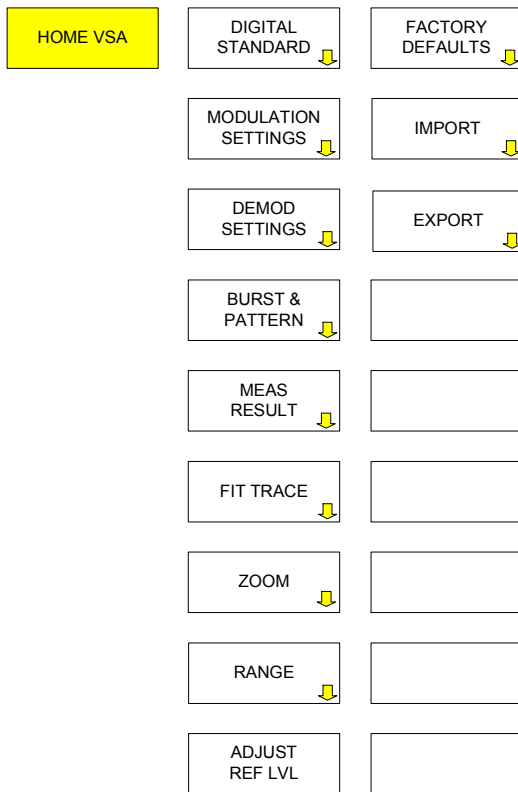

The *HOME VSA* hotkey opens the menu of the R&S FSQ-K70/FSMR-B73/FSU-B73 option with the following settings:

DIGITAL STANDARD opens a submenu for selecting measurements to be performed on digital standards.

MODULATION SETTINGS opens a submenu containing the settings used to define the modulation mode.

DEMOD SETTINGS opens a submenu with the settings relevant for demodulation.

BURST & PATTERN opens a submenu for parameterizing the burst search and the search for synchronization patterns that may be contained in the symbol stream.

MEAS RESULT opens a submenu with the settings for the demodulation result and the type of result display.

ZOOM opens a submenu with for selecting the displayed section of the capture buffer and for controlling the demodulation.

FIT TRACE opens a submenu for positioning the measurement result on the display.

RANGE opens a submenu with the scaling parameters for the display format.

ADJUST REF LVL automatically sets the level of the measuring instrument.

The right side menu offers the following settings:

- *FACTORY DEFAULTS* opens a submenu for restoring the factory-set default state.
- *IMPORT* opens a submenu for recalling filter, pattern, standards and mappings.
- *EXPORT* opens a submenu for saving filter, pattern, standards and mappings to an external floppy.

Measurements on Dig. Standards - DIG. STANDARD Softkey

Predefined Standards and Standard Groups

In the **Digital Standards** menu, predefined basic settings for standards can be selected and user-defined standards stored.

Note: *An export and import function is provided for transferring predefined and user-defined standards between different instruments (see HOME VSA menu).*

The most usual measurements are predefined as standard settings for a large number of mobile radio networks. The instrument comes ready with the following settings in these **standard settings**:

- Symbol rate
- Modulation mode and modulation filter
- Recording length
- Search for burst signals
- Synchronization to fixed signal patterns
- Measurement results
- Display range and scalings

The standard settings are grouped in a *GENERIC STANDARD* to facilitate selecting a standard. A *GENERIC STANDARD* is an organization criterion for standards with similar measurement tasks.

As an example, the settings for the following measurements are grouped under the predefined *GENERIC STANDARD* GSM_EDGE:

- GSM Normal Burst
- Access Burst
- Synchronization Burst
- Frequency Correction Burst
- Edge Normal Burst

Grouping itself is not subject to limitations or rules. Especially standards with different types of modulation and synchronization sequences can also be grouped in one group.

Users can easily define their own standards.

The *SAVE AS STANDARD* softkey is used to accept the current instrument setting with the above parameters including the synchronization patterns but **without frequency and level settings** of the basic instrument and to store them with user-defined names. The assignment of the new standard to a *GENERIC STANDARD* can be entered into the menu. Defining new groups is also easy.

The use of standards in several groups is possible. The user can thus generate a group shortcut with the preferred standard measurement settings

Individual standards can be grouped and selected without any limitation, i.e. the parameters may even belong to different mobile radio networks with completely different default setups.

A *GENERIC STANDARD* Y is only an **organization criterion** for the individual standards it contains.

Fig. 126 shows

- assignments of standards to groups of standards
- the multiple use of standards in various groups
- the use of user-defined standards and groups

The only restriction for defining a user-standard name is that it must be **unique**. This means that storing a new standard under an existing name is not possible for security reasons. The existing standard must be deleted before a standard can be stored under this name.

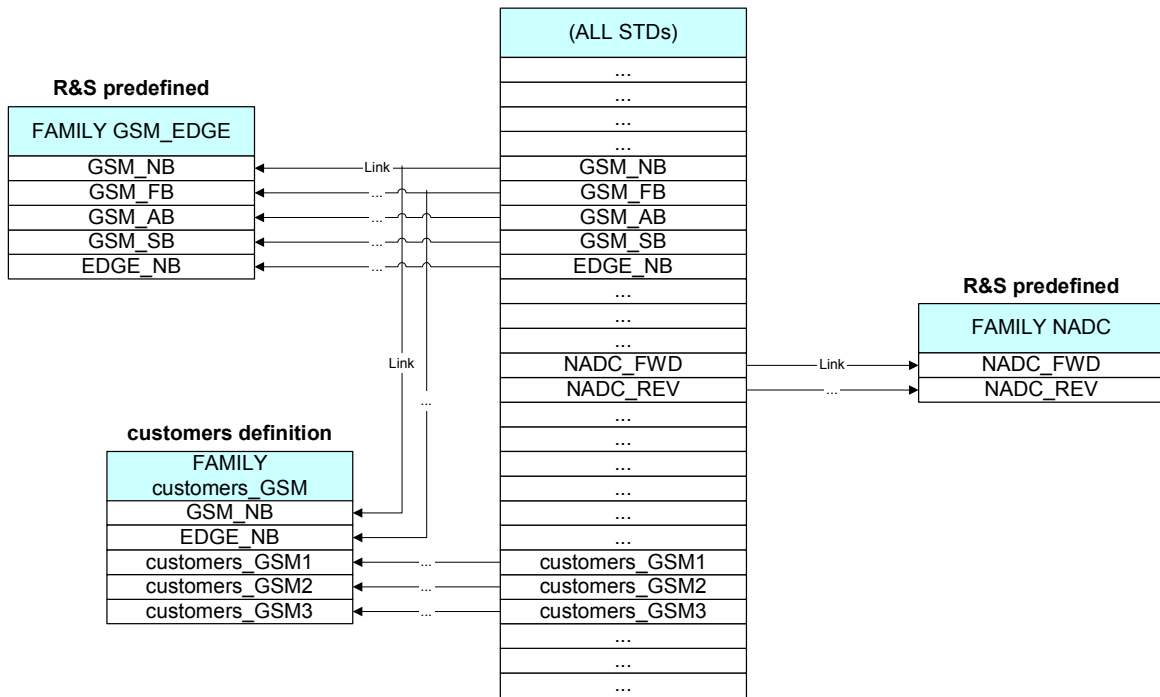

Fig. 126 Standard definition and grouping in groups

Example of operation:

The setting is performed in two steps: **selecting a standard group** and **selecting the standard measurement**.

After selection of a *GENERIC STANDARD* and acknowledgement, the focus is automatically set to the right-hand table (*STANDARDS*) for further selection.

The table below contains predefined standards and their default settings.

List of Predefined Standards and Standard Groups

Modulation /generic group	Standard	Modulation	Symbol rate	Filter & Mapping Transmit Filter Receive Filter Measure. Filter Mapping	Alpha BT	REF Deviation (FSK)	Search for Burst	Search for Pattern	Pattern Position	Pattern	Record Length	Result Length	Eval Line 1	Eval Line 2	Fit	Fit Offset	Set Symbol	Points / Symbol	Result Raw / Filt	Screen A / B
APCO25	APCO25_C4FM	4FSK	4.8 kHz	APCO25_C4FM_TX APCO25_C4FM_ISI APCO25_C4FM_ISI Mapping: APCO25_C4FM	-	1.8 kHz						200			Trigger to Left			4	FILT	Freq Error / Modu. Acc
	APCO25_CQPSK	Pi4-DQPSK	4.8 kHz	RRC NONE NONE Mapping: APCO25	0.2	-						200			Trigger to Left			4	FILT	Meas Const / Modu. Acc
	APCO25_F4FM	4FSK	4.8 kHz	APCO25_F4FM_TX APCO25_F4FM_ISI APCO25_F4FM_ISI Mapping: APCO25_F4FM	0.22	4 kHz						200			Trigger to Left			4	FILT	Freq Error / Modu. Acc
GSM-EDGE	GSM_NB	DMSK	270.833 kHz	GAUSS NONE NONE Mapping: GSM	0.3	-	X	X		GSM_TSC0 GSM_TSC7		148	3		Pattern to Center			4	FILT	Phase Error / Modu. Acc
	GSM_SB	DMSK	270.833 kHz	GAUSS NONE NONE Mapping: GSM	0.3	-	X	X		GSM_SB0 GSM_SB2		148	42		Pattern to Center			4	FILT	Phase Error / Modu. Acc
	GSM_FB	DMSK	270.833 kHz	GAUSS NONE NONE Mapping: GSM	0.3	-	X	X		GSM_FB0 GSM_FB01		148	3		Pattern to Center			4	FILT	Phase Error / Modu. Acc
	GSM_AB	DMSK	270.833 kHz	GAUSS NONE NONE Mapping: GSM	0.3	-	X	X		GSM_AB0 GSM_AB2		88	8		Pattern to Center			4	FILT	Phase Error / Modu. Acc
	EDGE_NB	3pi-8PSK	270.833 kHz	GAUSS_LINEARIZED EDGE_ISI EDGE_MEAS Mapping: WCDMA	-	-				EDGE_TSC0 EDGE_TSC7		148	3		Pattern to Center			4	FILT	EVM/ Modu. Acc
3G_WCDMA	3G_WCDMA_FWD	QPSK	3.84 MHz	RRC RRC RRC Mapping: WCDMA	0.22	-						800	0		Trigger to Left			4	FILT	Meas Const/ Modu. Acc
	3G_WCDMA_REV	QPSK	3.84 MHz	RRC RRC RRC Mapping: WCDMA	0.22	-						800			Trigger to Left			4	FILT	Meas Const/ Modu. Acc
CDMA2K	CDMA2K_1x_FWD	QPSK	1.2288 MHz	CDMA2K_1X_FWD_TX CDMA2K_1X_FWD_ISI CDMA2K_1X_FWD_ISI Mapping: CDMA2K_FWD	-	-						800	0		Trigger to Left			4	FILT	Meas Const/ Modu. Acc

R&S®FSQ-K70/FSMR-B73/FSU-B73

List of Predefined Standards and Standard Groups

Modulation /generic group	Standard	Modulation	Symbol rate	Filter & Mapping Transmit Filter Receive Filter Measure. Filter Mapping	Alpha BT	REF Deviation (FSK)	Search for Burst	Search for Pattern	Pattern Position	Pattern	Record Length	Result Length	Eval Line 1	Eval Line 2	Fit	Fit Offset	Set Symbol	Points / Symbol	Result Raw / Filter	Screen A / B
	CDMA2K_1X_REV	QPSK	1.2288 MHz	CDMA2K_1X_REV_TX CDMA2K_1X_REV_ISI CDMA2K_1X_REV_ISI Mapping: CDMA2K_REV	-	-						800	0		Trigger to Left			4	FILT	Meas Const/ Modu. Acc
	IS95_FWD	QPSK	1.2288 MHz	CDMA2K_1X_FWD_TX CDMA2K_1X_FWD_ISI CDMA2K_1X_FWD_ISI Mapping: CDMA_FWD	-							800	0		Trigger to Left			4	FILT	Meas Const/ Modu. Acc
	IS95_REV	Pi4-DQPSK	24.3 kHz	CDMA2K_1X_REV_TX CDMA2K_1X_REV_ISI CDMA2K_1X_REV_ISI Mapping: CDMA2K_REV	-					NADC_S1 ... NADC_S6		162	0		Pattern to Center			4	FILT	Meas Const/ Modu. Acc
NADC	NADC_FWD	Pi4-DQPSK	24.3 kHz	RRC RRC RRC Mapping: NADC	0.35			X		NADC_S1 ... NADC_S6		162	0		Pattern to Center			4	FILT	Meas Const/ Modu. Acc
	NADC_REV	Pi4-DQPSK	24.3 kHz	RRC RRC RRC Mapping: NADC	0.35		X			NADC_S1 ... NADC_S6		156	6		Burst to Center			4	FILT	Meas Const/ Modu. Acc
PDC	PDC_DOWN	Pi4-DQPSK	21 kHz	RRC RRC RRC Mapping: PDC	0.35		X	X		PDC_S1 ... PDC_S12		138			Pattern to Center			4	FILT	Meas Const/ Modu. Acc
	PDC_UP	Pi4-DQPSK	21 kHz	RRC RRC RRC Mapping: PDC	0.5		X			PDC_S1 ... PDC_S12		135	3		Burst to Center			4	FILT	Meas Const/ Modu. Acc
PHS	PHS_UPDN	Pi4-DQPSK	192 kHz	RRC RRC RRC Mapping: PHS	0.5		X			PHS_DO1 PHS_DO2 PHS_UP1 PHS_UP2		110	2		Burst to Center			4	FILT	Meas Const/ Modu. Acc
TETRA	TETRA_NDDOWN	Pi4-DQPSK	18 kHz	RRC RRC RRC Mapping: TETRA	0.5		X			TETRA_S1 ... TETRA_S3		246	2		Burst to Center			4	FILT	Meas Const/ Modu. Acc
	TETRA_NCDOWN	Pi4-DQPSK	18 kHz	RRC RRC RRC Mapping: TETRA	0.5		X			TETRA_E TETRA_S		255	7		Burst to Center			4	FILT	Meas Const/ Modu. Acc
DECT	DECT_FP	2FSK	1152 kHz	GAUSS NONE NONE Mapping: DECT	0.5	288 kHz	X			DECT_FP DECT_PP		424	16		Burst to Center			4	RAW	Freq Error/ Modu. Acc
BLUETOOTH	BLUETOOTH 1	2FSK	1000 kHz	GAUSS NONE	0.5	160 kHz-	X			BLUETH_AA BLUETH_FO		625	0		Burst to Left			4	RAW	Freq Error/ Modu. Acc

Modulation /generic group	Standard	Modulation	Symbol rate	Filter & Mapping Transmit Filter Receive Filter Measure. Filter Mapping	Alpha BT	REF Deviation (FSK)	Search for Burst	Search for Pattern	Pattern Position	Pattern	Record Length	Result Length	Eval Line 1	Eval Line 2	Fit	Fit Offset	Set Symbol	Points / Symbol	Result Raw / Filt	Screen A / B
				NONE Mapping: BLUETOOTH																
	BLUETOOTH 3	2FSK	1000 kHz	GAUSS NONE NONE Mapping: BLUETOOTH	0.5	160 kHz	X			BLUETH_AA BLUETH_FO		1875	0		Burst to Left			4	RAW	Freq Error/Modu. Acc
	BLUETOOTH_DH5	2FSK	1000 kHz	GAUSS NONE NONE Mapping: BLUETOOTH	0.5	160 kHz	X			BLUETH_AA BLUETH_FO		3125	0		Burst toLeft			4	RAW	Freq Error/Modu. Acc

DIGITAL STANDARD Menu

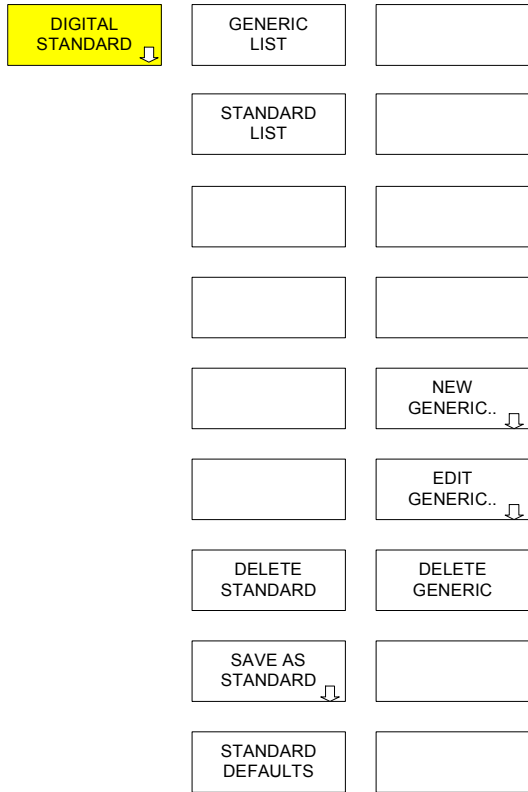

The *DIGITAL STANDARDS* softkey opens the submenu for selecting predefined measurement settings for conventional mobile radio standards.

In addition, the menu has setting items for **defining** and **deleting** digital standards as well as for configuring, modifying and deleting standard groups.

There is no item for editing a digital standard since the current device setup can be stored as user-specific standard with the *SAVE AS STANDARD* softkey.

After the *DIGITAL STANDARD* softkey is pressed, a window split in three parts is displayed. The currently set standard is displayed in the **upper window** (STANDARD DEFINITION). The predefined standard groups are displayed in the **bottom left window** (GENERIC STANDARD). The standards assigned to the currently selected group are displayed in the **bottom right window** (STANDARD).

A predefined measurement setting can be selected by marking the desired setting in the right column and then confirming the selection with ENTER.

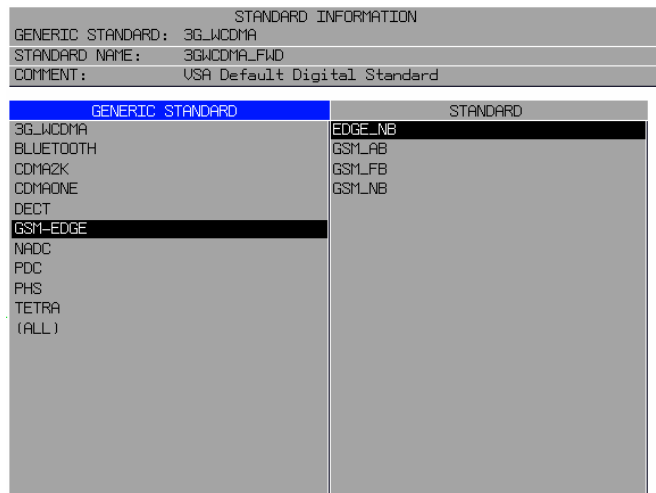

Fig. 127 Standard window

An entry (*ALL*) is contained in the list of standard groups. All standards defined in the instrument are provided under this entry on the right side.

IEC/IEEE bus command

:SENSe:DDEM:STAN:CAT?

:SENSe:DDEM:PRES.<standard>|<file name>



GENERIC LIST

The *GENERIC LIST* and *STANDARD LIST* softkeys toggle the focus between the left and right column of the table. Some softkeys are only available if the table column has been correctly selected.

STANDARD LIST



DELETE STANDARD

The *DELETE STANDARD* softkey deletes the marked standard. Standards predefined by Rohde & Schwarz can also be deleted. The softkey can be operated only if the entry focus is in the right table (*STANDARD LIST* softkey). A confirmation query is displayed to avoid unintentional deletion of the standard.

Note: *The standards predefined by Rohde & Schwarz available at the time of delivery can be restored using the FACTORY DEFAULTS softkey (HOME VSA menu).*

IEC/IEEE bus command `SENS:DDEM:STAN:DEL <file_name>`



STANDARD DEFAULTS

The *STANDARD DEFAULTS* softkey resets the R&S FSQ-K70/FSMR-B73/FSU-B73 option to the default setting of the standard last used.

IEC/IEEE bus command `SENS:DDEM:STAN:PRES`



SAVE AS STANDARD

The *SAVE AS STANDARD* softkey stores the current instrument setting as a user-defined standard.

A window is opened for entering the following parameters:

NAME Name of the new standard.
If a standard with the same name is available, overwriting is prohibited and the standard available must first be deleted. Each new standard is automatically stored in the list of all standards known (ALL Standards).

COMMENT Comment.

GENERIC STD First assignment to a standard group.
The newly defined standard can be entered into other groups later on. It is thus possible to group predefined standards with user-defined new standards to form a new group so that the work environment can be accessed rapidly.

PATTERN PREFIX Prefix file for synchronization patterns.
Patterns with this prefix are automatically entered into a selection list (PREFERRED PATTERN) for fast selection and are available for the pattern search without further configuration (see section "[Pattern Search List](#)").

SAVE AS STANDARD	
STANDARD	MYSTANDARD
GENERIC STANDARD	MYGROUP
COMMENT	
PATTERN PREFIX	
PATTERN POSITION	ON
PATTERN SYMB#	
FIT	
FIT OFFSET	
BURST SEARCH	
PATTERN SEARCH	

Fig. 128 Standard window



The **SAVE** softkey stores the current setting as standard; the standard is then displayed in the standard selection list. The patterns, filters and mappings for the standard are also saved.

The softkey then returns to the calling menu.

IEC/IEEE bus commands

```
SENS:DDEM:STAN:GRO <MYGROUP>
SENS:DDEM:STAN:COMM <TEST>
SENS:DDEM:STAN:PREF <PATTERN>
SENS:DDEM:STAN:SAVE "MYSTANDARD"
SENS:DDEM:STAN:SYNC:OFFS10
```

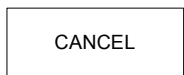

The **CANCEL** softkey refuses the entries and does not store them as a new standard.

The softkey then returns to the calling menu.
IEC/IEEE bus command-

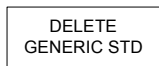

The **DELETE GENERIC STD** softkey deletes the currently selected standard group without deleting the associated individual standard in the overall list (ALL). The softkey can be operated only if the entry focus is in the left table (**STANDARD GROUP** softkey).

IEC/IEEE bus command-

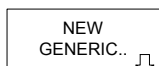

The **NEW GENERIC** and **EDIT GENERIC** softkeys open a submenu for defining and editing standard groups.

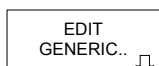

IEC/IEEE bus command-

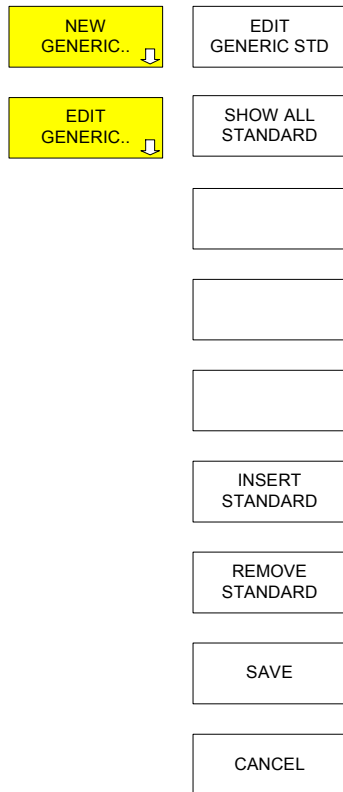

The *NEW GENERIC* softkey is used to define new standard groups and *EDIT GENERIC* to adapt available groups. For this purpose, a table that is divided into two parts is opened:

The left part of the table contains an entry mask for the name of the new group and a comment. In addition, all standards already entered in the group are listed.

The right part of the table contains a list of all digital standards available.

After a name and, if required, a comment for the new standard group have been entered, *SHOW ALL STANDARDS* is used to change to the right table. Associated standards in the list are then consecutively selected and entered into the group with the *INSERT STANDARD* softkey.

The definition of the standard group is terminated with the *SAVE* softkey.



Fig. 129 Definition of a standard group

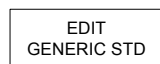

The *EDIT GENERIC STD* and *SHOW ALL STANDARDS* softkeys toggle the entry focus between the left and right table.



The left table shows the standard group and the assigned standards and the right table contains all standard definitions known (*ALL STANDARDS*).

IEC/IEEE bus command-



The *INSERT STANDARD* softkey enters the highlighted standard into a standard group. To do this, the entry focus must be on the right part of the table (*SHOW ALL STANDARDS* Softkey).



The *REMOVE STANDARD* softkey deletes the highlighted standard from the list of the standard group without deleting the standard.

IEC/IEEE bus command-



The *SAVE* softkey saves the current standard assignment to the current group under the set name.



The *CANCEL* softkey is used to cancel editing without storing any data. In both cases, the softkey returns to the calling menu.

IEC/IEEE bus command-

Exiting a Standard

If **standard instrument settings** are changed, the analyzer displays the **modulation mode** instead of the digital standard in the function panel "Standard / Modulation". This prevents the analyzer from signalling standard-conforming measurements even if standard settings were made changed.

The following parameter changes cause a digital standard to be exited:

- modulation mode (PSK; MSK; FSK; QAM)
- symbol rate (SYMBOL RATE)
- filter and filter parameters
- EVM calculation formula (EVM CALC)

Resetting the corresponding setting parameter to standard-conforming values does **NOT** result in a return to the standard. To return to the standard, either select the corresponding standard again (via DIGITAL STANDARDS) or select the STANDARD DEFAULTS softkey to return to the standard last selected.

The following settings do not cause the standard to be exited:

- modification of display formats
- modification of display scaling
- pattern

BURST & PATTERN Softkey

The settings for the sync pattern and for the burst are combined in the *BURST & PATTERN* menu.

Burst and Search Parameters

The basic operation of the algorithm has already been described in section 3. The present section describes the effects of the operating parameters on the burst search.

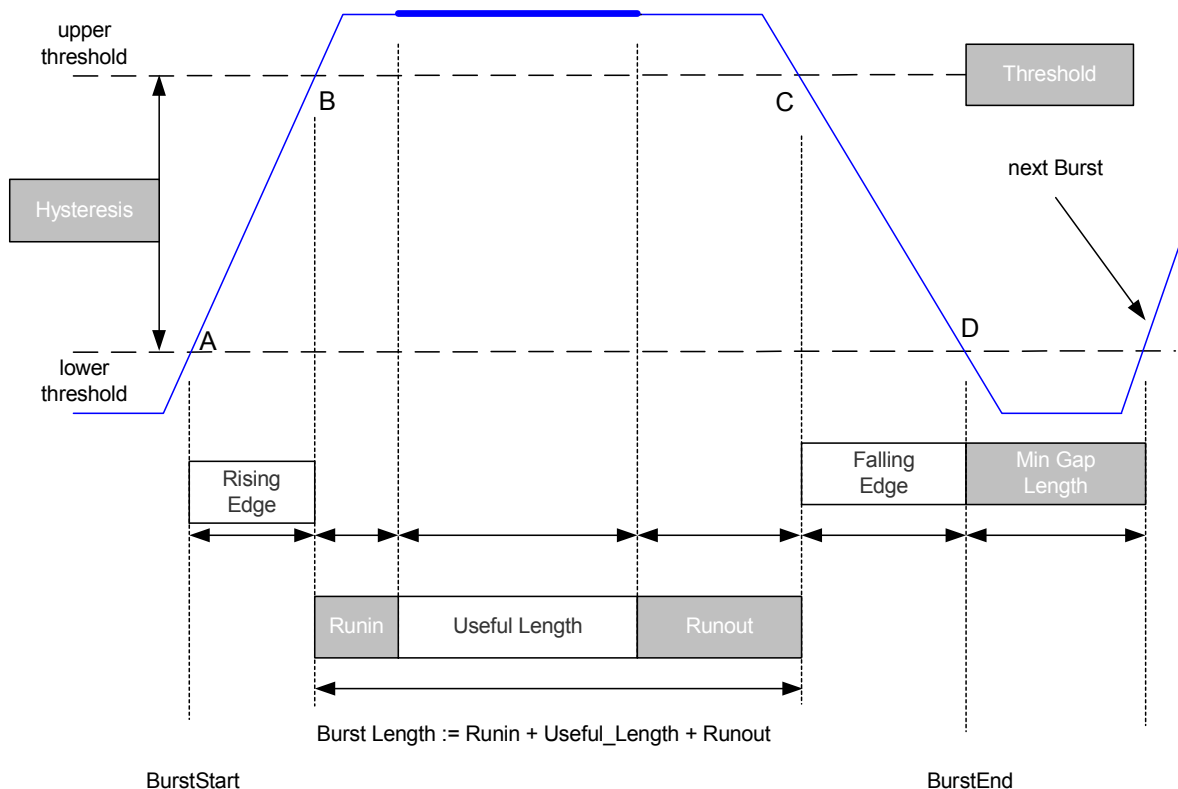

Fig. 130 Burst model of analyzer, where grey fields are operating parameters

Fig. 130 shows a burst with the operating parameters that are required for manual burst search. The figure shows points A and D when the burst level exceeds or falls below the lower threshold and points B and C for the upper level threshold.

The inner burst range (USEFUL RANGE) plays a decisive role for further demodulation. After detection of the burst edges, the range (B,C) is further limited via parameters RUNIN or RUNOUT. In this inner range, the analyzer assumes stable and settled signal ratios.

- The demodulation range of the demodulator as well as the search range for sync patterns are limited to this range.
- The operating range of the matching algorithm is also limited to this range unless standard-specific definitions have priority.

The following parameters are evaluated and corrected in the Useful Length:

- Center Frequency Error
- Symbol Timing
- Symbol Phase
- Origin Offset
- Amplitude Droop (only evaluation, no correction)

These parameters are then applied to the complete Demodulation Range, ie also to the range outside the burst.

Other test parameters such as the following are determined by the *EVAL RANGE* (see section "[Evaluation Lines / Limiting the Measurement Range](#)").

- EVM
- Phase Error
- Frequency Error (MSK, FSK)

This ensures a stable demodulation and measurement even if the user extends the measurement range to a burst range (by means of EVAL LINES) or ranges outside the burst.

The burst search can be performed in three different ways depending on the operating mode "Digital Standard" or "Digital Demodulation" (no standard is active).

	Digital standard	No standard
Fully automatic burst search	All burst search parameters are determined by the analyzer. The useful length definition is implemented by the standard (Useful Part).	All burst search parameters are determined by the analyzer. The following settings are defined: Useful length = 100 symbols Max burst length = 1600 symbols
Manual search	All parameters can be set by the user.	All parameters can be set by the user.

The following distinctions are made:

- In the case of "**Standard active**", the nominal burst length of the standard definition determines the minimum and maximum values for the search range.
- In the case of "**No standard**", the useful length and maximum burst lengths determine the search range. In this special case, the burst search recognizes all bursts in this tolerance range and modifies the USEFUL BURST LENGTH for every measurement.
- If **SweepCount > 1** and the AVERAGE function are additionally activated (averaging over several measurements), averaging over bursts of different lengths is avoided by limiting the USEFUL BURST RANGE and the demodulation range of the NDA demodulator to the minimum burst length.

Multiple Evaluation of a Captured Data Record (MULTI)

Signal processing with MULTI OFF carries out exactly one demodulation per measured data capture and displays the results.

MULTI ON enables you to carry out multiple evaluations from a single data record. This mode greatly simplifies searching for modulation signal errors that occur infrequently.

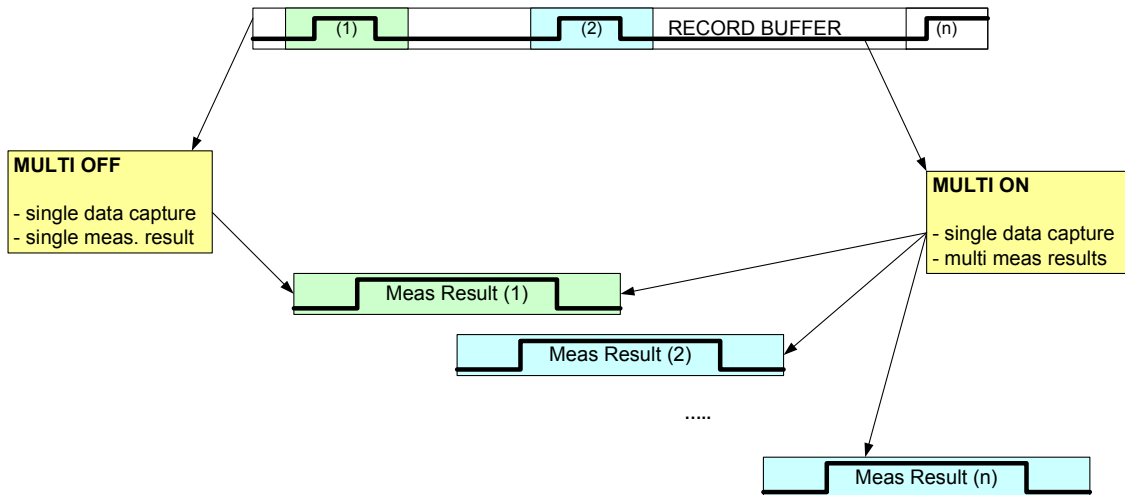

Fig. 131 MULTI ON/MULTI OFF: Multiple measurement evaluations per data capture

Although the record length can be set as small as possible for normal measurement demodulation in order to keep the measurement time short, increase the record buffer to its maximum value of 16 Msamples in this case. Use the ZOOM or SWEEP menu to control demodulation.

Fig. 131 shows a result display when multi-processing is active. The top diagram shows the magnitude of the record buffer. The lower diagram shows the magnitude of the demodulated signal. In the example, the size of the record buffer is 100000 samples per buffer.

The section of the record buffer that is displayed is determined by the **ZOOM LENGTH** parameter. The maximum size is 32000 samples. To provide better orientation, the entire record buffer is symbolized as a grey bar at the top of the diagram and the area of the capture buffer that is actually being displayed is indicated in red within the bar. The demodulated range (result range) is indicated with a green bar. The navigation bars are visible only when MULTI = ON.

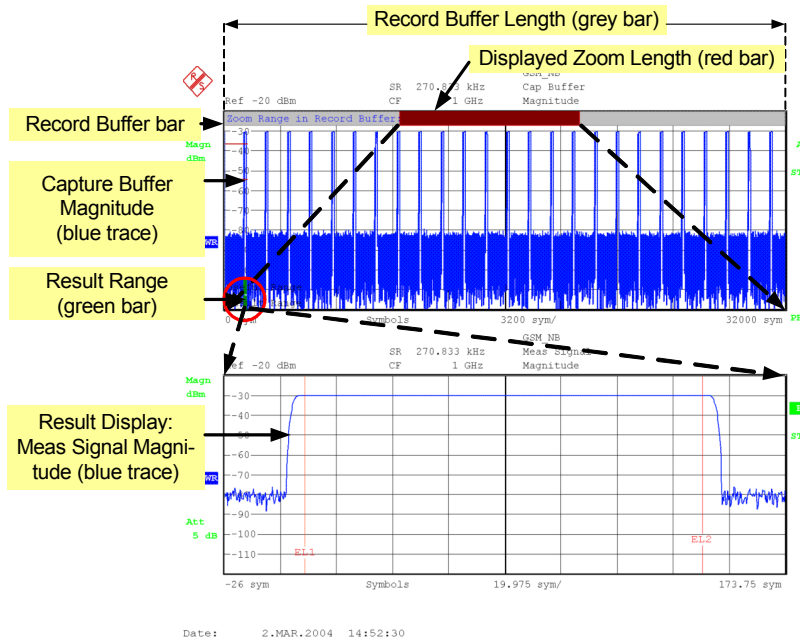

Fig. 132 Screenshot of multiple processing.
 Upper trace: Capture buffer magnitude (zoomed view),
 Lower trace: Measurement signal magnitude

Controlling the Evaluation

Use the softkeys *DEMOD NEXT RIGHT*, *DEMOD RESTART* and *DEMOD @ ZOOM START* to control multiple evaluation.

Use *DEMOD NEXT RIGHT* to demodulate the next block. If burst search is active, the next burst will be demodulated (Fig. 134). If burst search is inactive, the immediately following block will be measured (Fig. 133).

If the demodulation area exceeds the displayed ZOOM area, the ZOOM area will automatically shift accordingly (Fig. 135).

DEMOD @ ZOOM START resets the demodulation area to the start of the current ZOOM area (Fig. 136). *DEMOD RESTART* resets the demodulation area to the start of the captured data (Fig. 137). Each time capture of measured data is restarted, **ZOOM START** resets to 0.

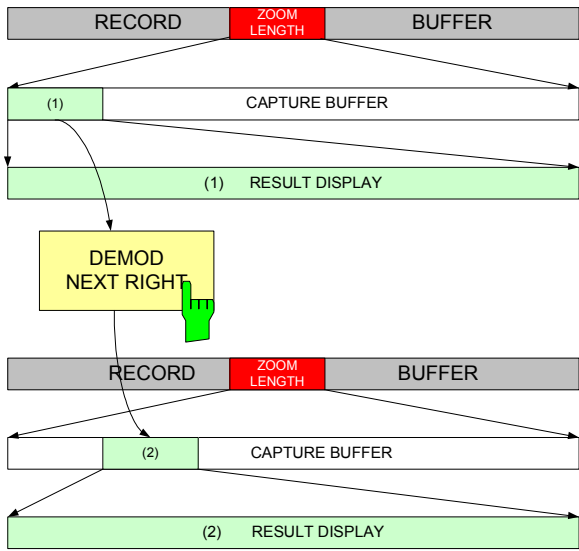

Fig. 133 DEMOD NEXT RIGHT: Demodulation of the adjacent signal section

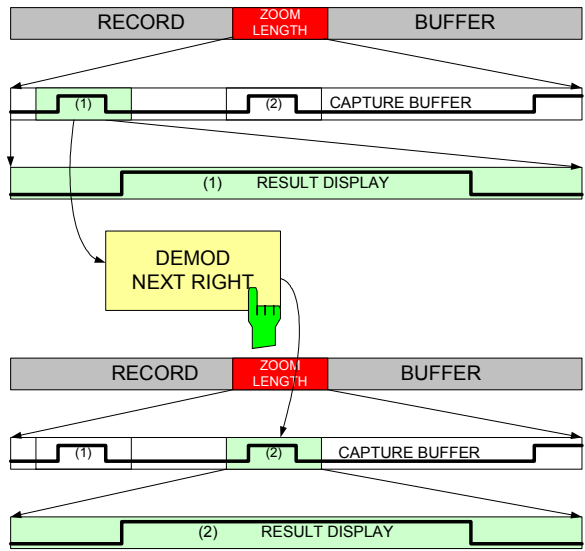

Fig. 134 DEMOD NEXT RIGHT Burst signal, demodulation of the next burst signal

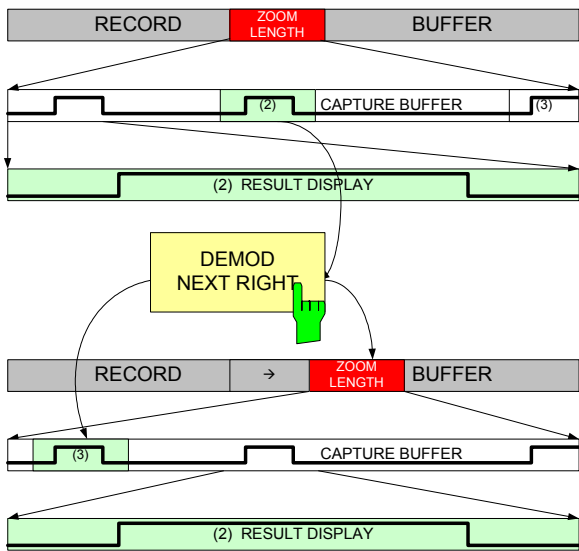

Fig. 135 DEMOD NEXT RIGHT: Automatic shifting of the ZOOM area

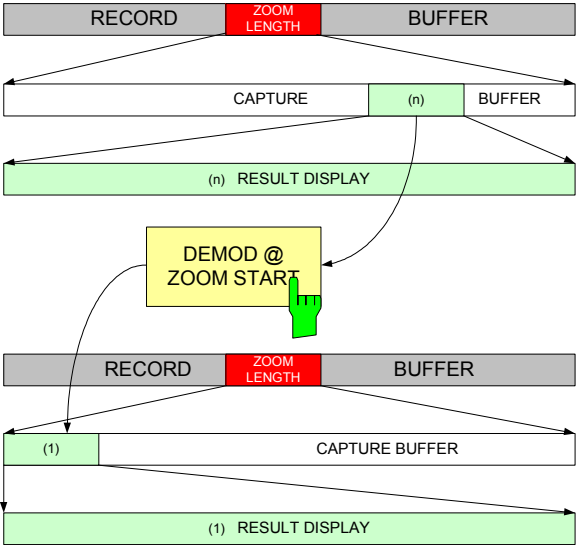

Fig. 136 DEMOD @ ZOOM START: Reset to the start of the zoom window

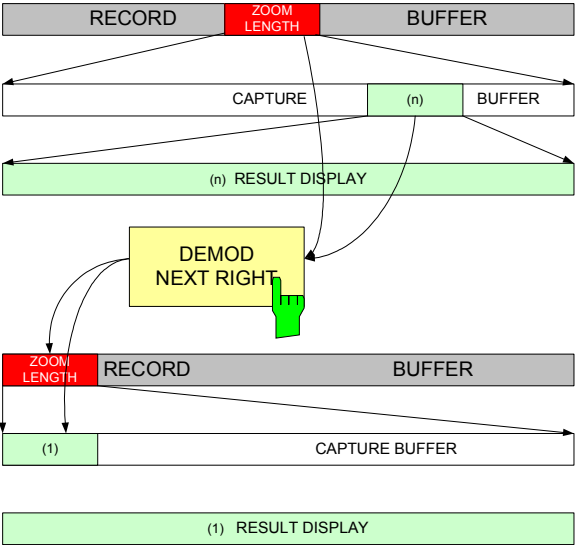

Fig. 137 DEMOD RESTART: Reset to the start of the record buffer

Controlling Data Capture

In both cases (MULTI = ON and MULTI = OFF), the capture of new measured data is controlled with the *CONTINUOUS SWEEP* and *SINGLE SWEEP* softkeys. In continuous sweep mode, data is automatically captured after each measurement. In single sweep mode, new data capture and the first evaluation are performed each time the *SINGLE SWEEP* softkey is pressed. You can then perform additional measurement evaluations by pressing *DEMOD NEXT RIGHT*. If no more data is present for evaluation, the message "End of Buffer" will appear. In this case, you can use *CAPTURE = AUTO* (and thus avoid having to enter data) to perform a new data capture, suppress the message and start the next evaluation.

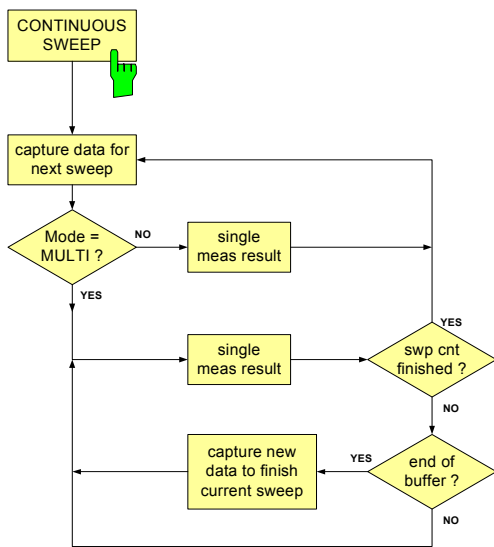

Fig. 138 *CONTINUOUS SWEEP*: Automatic data capture

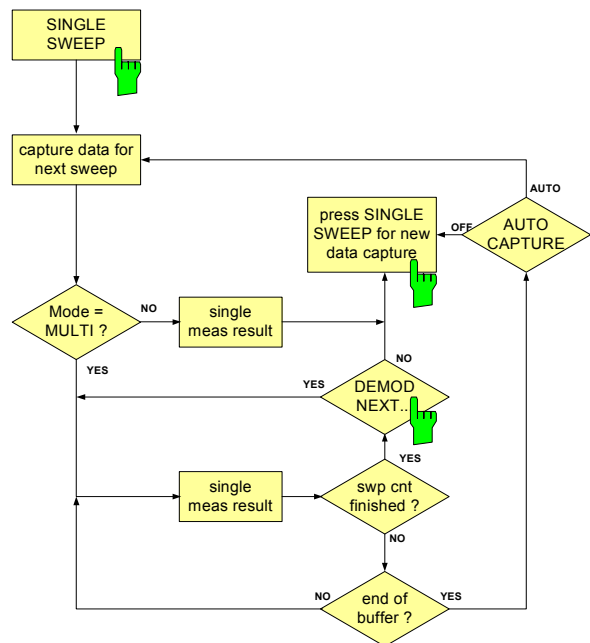

Fig. 139 *SINGLE SWEEP*: Automatic data capture at end of the record buffer if *CAPTURE = AUTO*

Burst and Search Parameters for Predefined Standards

Standards				Burst Settings			Expert Burst Settings				
Standard group	Standard	Nominal Frame Length (Standard)	Result Length	Search Burst on	Search Mode	Hysteresis	Useful Length	Max Length	RUNIN	RUNOUT	Min GAP Length
GSM-EDGE	GSM_NB	147	148	X	AUTO		146	166	2	2	1
	GSM_SB	147	148	X	AUTO		146	166	2	2	1
	GSM_FB	147	148	X	AUTO		146	166	2	2	1
	GSM_AB	87	86	X	AUTO		86	106	7	2	1
	EDGE_NB	147	148	X	AUTO		146	166	2	2	1
NADC	NADC_FWD	162	152		AUTO		150	160	2	2	1
	NADC_REV	162	156	X	AUTO		150	160	2	2	1
PDC	PDC_DOWN	140	135	X	AUTO		130	140	2	2	1
	PDC_UP	140	135	X	AUTO		130	140	2	2	1
PHS	PHS_UPDN	120	110	X	AUTO		105	115	2	2	1
TETRA	TETRA_NDDOWN			X	AUTO						
	TETRA_NCDOWN			X	AUTO						
DECT	DECT_FP	436	424	X	AUTO		430	480	2	2	1
BLUETOOTH	BLUETOOTH1	366	625	X	AUTO		364	625 (1 slot)	5	2	312 (1/2 slot)
	BLUETOOTH3	1622	1875	X	AUTO		1620	1875 (3 slots)	5	2	312 (1/2 slot)
	BLUETOOTH_DH5	2870	3125	X	AUTO		2868	3125 (5 slots)	5	2	312 (1/2 slot)

All numeric values are given in symbols.

Pattern and Pattern Lists

Since sync patterns provide a fixed symbol pattern at a defined point in time in the symbol stream, they are used in many digital mobile radio systems to evaluate the channel impulse response and to facilitate a demodulation in the receiver.

After demodulation down to the symbol level, the R&S FSQ-K70/FSMR-B73/FSU-B73 option can synchronize to a pattern and adapt its result range to this pattern. In the case of a digital standard, several patterns to be searched for during the measurement can be selected from a list.

In a GSM burst, for example, all specific patterns TSC0...7 can be searched for. The recorded and demodulated symbol stream is searched in the given sequence of patterns. The search is stopped after the first stream has been found. The result range is adapted to the known position of the pattern in the burst and the set measurement parameters are determined for this limited measurement range.

In the case of a multiple search, only patterns of the same length and same pattern position in the data stream are useful. A simultaneous activation of patterns that do not comply with these criteria is not accepted by the system.

Predefined Patterns and List Structures

Common standards usually have predefined pattern lists (*PATTERN STANDARD LIST*) with standard-specific patterns. Sync patterns required for the current measurement can only be selected from this list. This list can be extended by patterns that are already available in the analyzer. Or newly edited patterns can be added to the list.

Note: *An export and import function is provided for transferring predefined and user-defined standards between different instruments (see HOME VSA menu).*

Extending the Pattern List

The following selections are offered to extend the pattern standard list:

- The first selection level (*PREFERRED PATTERN*) only offers those patterns with a common (defined in the digital standard) PREFIX (e.g. GSM_).
- The second selection level (*COMPATIBLE PATTERN*) also offers those patterns that are compatible with the selected degree of modulation. This includes those patterns with a deviating prefix, e.g. due to deviating customer-specific sorting criteria. Patterns of different standards are also displayed at this level.
- The third selection level (*ALL PATTERN*) displays all patterns. This level is primarily used to define and change patterns.

Creating a New Pattern

A **new entry** of a pattern is made in the *ALL PATTERN* list. Derived lists such as *COMPATIBLE PATTERN* and *PREFERRED PATTERN* are automatically adapted, if required. A pattern can be entered into the standard list only by means of a user command or by loading data from a floppy disk or by an IEC/IEEE bus command.

Deleting and Removing a Pattern

Patterns can be **removed** very easily from predefined or user-defined standard lists (*REMOVE PATTERN FROM LIST*).

Predefined R&S patterns cannot be **deleted** from the list (*ALL PATTERN*) whereas the deletion of customer-specific patterns is possible. Derived lists are adapted automatically.

Pattern Search List

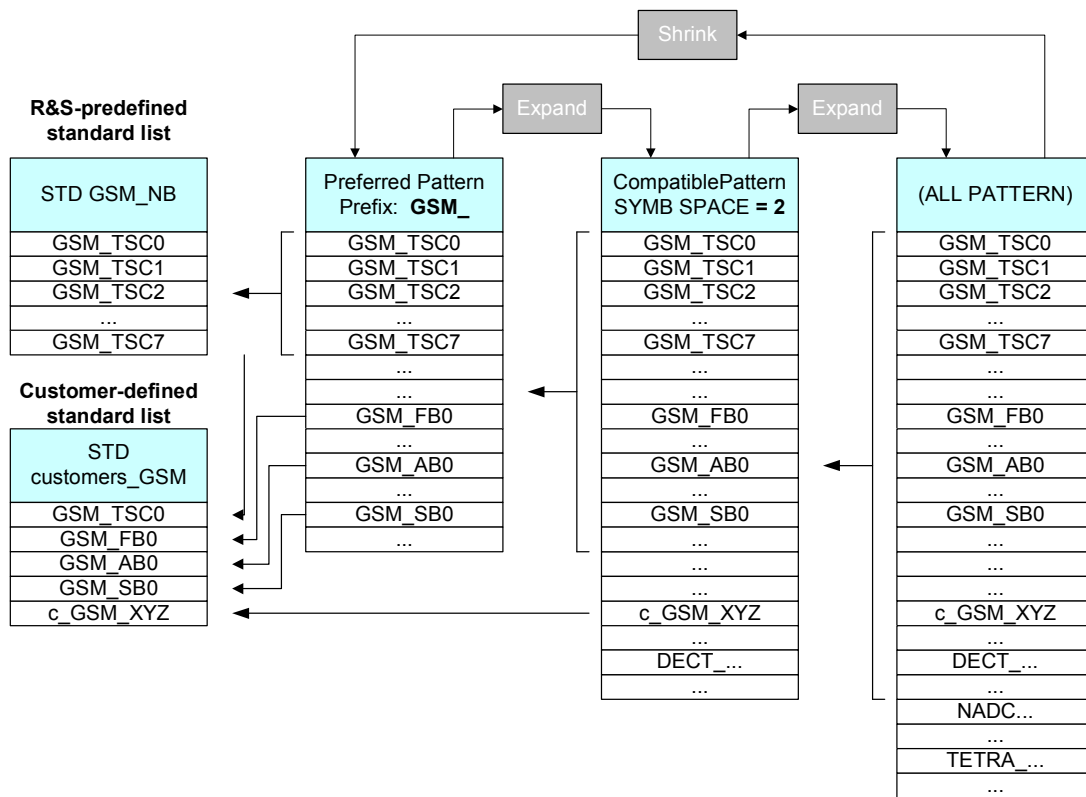

Fig. 140 Pattern lists

Fig. 140 gives an **overview** of how sync patterns are grouped to form digital standards.

Example:

The user defines a custom standard named “customers_GSM” and selects the *PREFERRED PATTERN* prefix “GSM” in the standard definition.

The user selects the patterns GSM_TSC0, GSM_FB0, GSM_AB0 and GSM_SB0 one after the other from the *PREFERRED* list and enters these patterns into the custom standard list.

The next pattern c_GSM_XYZ is not contained in this list. Therefore, the search is continued in the next selection list of *COMPATIBLE PATTERN*, where this pattern is selected and again saved in the standard list.

In particular, this *COMPATIBLE* list contains patterns that are suitable for the selected standard but have a different prefix such as customer-specific definitions ‘c_GSM’.

The *EXPAND* softkey is used to **switch** from the *PREFERRED PATTERN* list to the *COMPATIBLE PATTERN* list. This softkey is also used to switch to the *ALL PATTERN* list. In the list last mentioned, the labelling and function of the *EXPAND* softkey is modified and becomes a *SHRINK* softkey. If this softkey is pressed, the *PREFERRED* list will again be displayed.

BURST & PATTERN Menu

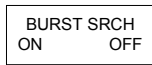

The *BURST & PATTERN* softkey opens a submenu for setting and parameterizing the search for bursts and sync patterns.



When a digital standard is selected, all parameters - including the SETS of the patterns - are set to default values.



BURST SRCH Switches the burst search on or off.

THRESHOLD Sets a level threshold for the burst search.

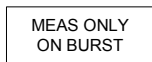

EXPERT SETTINGS Opens a submenu to manually set the burst search parameters.



MEAS ONLY ON BURST Measurement results are only displayed if a valid burst has been found. For averaged measurements of burst signals (*BURST SRCH=ON*), *MEAS ONLY ON BURST* should be activated so that erroneous measurements do not affect the result of averaging.



PAT SRCH Switches the search for a sync pattern on or off.

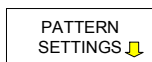

SELECT PATTERN Selects one or more patterns for the measurement.

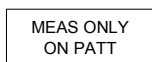

PATTERN SETTINGS Opens a submenu to control the pattern selection list and to edit the patterns.

MEAS ONLY ON PATT Measurement results are displayed only if a valid burst has been found. For averaged measurements with active pattern search, *MEAS ONLY ON PATT* should be activated so that erroneous measurements do not affect the result of averaging.



The *BURST SRCH ON/OFF* softkey switches the burst search for the measurement signal on or off.

Measurements on burst input signals should be performed with the setting *BURST SRCH ON*:

In the first processing stage, the rising and falling burst edges are recognized and the internal processing lengths, which are used to find the modulation parameters, are adapted to the recognized burst length.

Measurements on unburst signals should normally be performed with the setting *BURST SRCH OFF* to avoid any erroneous detection due to the dynamic range of the signal.

The error message *BURST NOT FOUND* is displayed if an evaluation of the recorded *RECORD MEMORY* does not reveal any burst structure that meets the following requirements at the same time:

- level threshold is exceeded
- useful length
- maximum burst length

If an applied burst signal is detected unreliably due to difficult receiving conditions, it is useful to support automatic burst search with *EXPERT SETTINGS* and to use the external trigger input of the measuring instrument together with a trigger offset setting.

After activating the burst search or pattern search, the **positioning of the measurement result** on the screen should also be adapted using FIT TRACE, in order to achieve a stable display.

If the burst search is activated without a simultaneously activated pattern search, the best setting to use is FIT BURST.

If the pattern search is active, the display of the measurement result should be adjusted to the found pattern (section "Positioning of Displays on Screen - FIT TRACE Softkey").

The page menu associated with FIT TRACE also contains the operating parameter PAT POS (pattern position), which specifies the expected position of the pattern from the start of the USEFUL LENGTH.

IEC/IEEE bus command :SENS:DDEM:SEAR:BURS:STAT ON

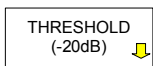

The *THRESHOLD* softkey opens a submenu to set a **level threshold and the hysteresis for burst search**.

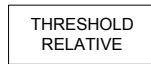

For numeric settings, the current threshold (dB or dBm) is displayed in the softkey. For automatic settings, (AUTO) will be displayed.

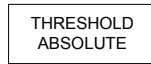

Three options are available for the level threshold:

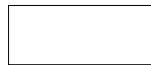

THRESHOLD AUTO
THRESHOLD RELATIVE
THRESHOLD ABSOLUTE



The hysteresis is set with the *HYSTERESIS MAN* softkey.

The set modulation mode (PSK, MSK, QAM, FSK) determines the hysteresis of the burst search and makes the burst search insensitive to the modulation-specific dynamic range of the corresponding modulation mode.

The burst (starting at the beginning of the *RECORD MEMORY*) meeting the level and hysteresis requirement and the minimum requirement for the burst length of the level is used for further demodulation (see also *EXPERT SETTINGS*).

The setting *AUTO* is normally used for normal demodulation settings.

If the burst search was not successful, the message *BURST NOT FOUND* would be output. However, a measurement will be performed in any case.



The *THRESHOLD AUTO* softkey activates the automatic setting of the threshold required for the burst search.

The analyzer classifies its *RECORD BUFFER* according to the maximum level occurring and derives the burst search thresholds from the maximum level and the set modulation mode.

IEC/IEEE bus command :SENS:DDEM:SEAR:BURS:THR:AUTO ON

THRESHOLD
RELATIVE

The *THRESHOLD RELATIVE* softkey activates the entry of a relative threshold required for the burst search.

A numeric threshold (with reference to the set reference level (see *REFERENCE LEVEL* softkey) must be entered. The setting value is maintained even if the reference level is modified. An absolute threshold is internally calculated based on this relative threshold and the reference level setting. The absolute threshold is then adapted to the reference level setting.

IEC/IEEE bus commands: :SENS:DDEM:SEAR:BURS:THR:AUTO
OFF

:SENS:DDEM:SEAR:BURS:THR:MODE REL
:SENS:DDEM:SEAR:BURS:THR:LEV <num>

THRESHOLD
ABSOLUTE

The *THRESHOLD ABSOLUTE* softkey activates the entry of a fixed threshold required for the burst search.

A numeric threshold also has to be entered which is interpreted as an absolute setting value. A modification of the reference level does not have any effect on this absolute threshold.

IEC/IEEE bus commands :SENS:DDEM:SEAR:BURS:THR:AUTO
OFF

:SENS:DDEM:SEAR:BURS:THR:MODE ABS
:SENS:DDEM:SEAR:BURS:THR:LEV <num>

HYSTERESIS
MAN

The *HYSTERESIS MAN* softkey activates the entry of a fixed hysteresis required for the burst search.

The hysteresis setting is referenced to the upper threshold (Threshold).

IEC/IEEE bus command :SENS:DDEM:SEAR:BURS:HYST:LEV 9
dB

EXPERT
SETTINGS

The *EXPERT SETTINGS* softkey opens a table for settings that are used to accurately control the behaviour of the burst search even under difficult measurement conditions.

EXPERT SEARCH SETTINGS		
	Symbols	Time
Useful Length	142	524.3083 μ s
Max Length	166	612.9238 μ s
Runin	2	7.384624 μ s
Runout	2	7.384624 μ s
Min Gaplen	1	3.692312 μ s

Fig. 141 Settings of burst search

- Useful Length** Setting value for minimum burst length (see figure Fig. 130, USERFUL LENGTH).
- Max Length** Setting value for maximum burst length.
- Runin** Setting value for the cut after the rising burst edge for the first demodulation.
- Runout** Setting value for the cut prior to the falling burst edge for the first demodulation.
- Min Gaplen** Setting value for the size of the gap between two successive bursts.

For predefined R&S standards, these values are **explicitly set** to default values. For user-defined standards, the current device settings are stored in the standard definition and are also set to default values.

The corresponding parameters can be entered both in time and symbols. They are rounded up to complete symbols or to times that correspond to complete symbols.

IEC/IEEE bus commands

```

:SENS:DDEM:SEAR:BURS:LENG:MIN <num_value>
:SENS:DDEM:SEAR:BURS:LENG:MAX <num_value>
:SENS:DDEM:SEAR:BURS:SKIP:RIS <num_value>
:SENS:DDEM:SEAR:BURS:SKIP:FALL <num_value>
:SENS:DDEM:SEAR:BURS:GLEN:MIN <num_value>

```

MEAS ONLY
ON BURST

The *MEAS ONLY ON BURST* softkey ensures that complete measurements are performed only if a burst complying with the above criteria has been found.

If no burst was found, processing in the demodulator is stopped at an early stage **without further measurement results or a screen display being available**.

The analyzer will immediately be ready for a new data recording and evaluation.

For averaged measurements of burst signals (BURST SRCH=ON), MEAS ONLY ON BURST should be activated so that erroneous measurements do not affect the result of averaging.

IEC/IEEE bus command : SENS:DDEM:SEAR:BURS:MODE BURS

PAT SRCH
ON OFF

The *PAT SRCH ON/OFF* softkey switches the search for sync patterns in the sync data set on or off. If the sync pattern is found, the zero point of axial scaling is adapted according to the definition of the standard.

IEC/IEEE bus command : SENS:DDEM:SEAR:SYNC:STAT ON|OFF
: SENS:DDEM:SEAR:SYNC:FOUN?

PATTERN
SELECT

The *PATTERN SELECT* softkey opens a table to select a pattern.

This selection list offers only those patterns that are defined for this standard.

The first line of the table can also be used to set whether the burst search is to be performed for a single pattern (**MULTI OFF**) or for several patterns (**MULTI ON**). With **MULTI ON** selected, several patterns of the list can be selected. With **MULTI OFF** selected, only one pattern can be selected from the list.

PATTERN SELECT	
MULTI	NO
<ADD PATTERN>	
GSM_TSC0	
GSM_TSC1	
✓GSM_TSC2	
GSM_TSC3	
GSM_TSC4	
GSM_TSC5	
GSM_TSC6	
<DOWN>	

Fig. 142 Pattern Select

For extension or new creation of a pattern set, see next section.

IEC/IEEE bus command : SENS:DDEM:SEAR:SYNC:SEL "GSM_TSC2", 3

Selection of sync patterns without standard being set

If no digital standard is set, the *PATTERN SELECT* softkey will open a list of all patterns that are compatible with the selected degree of modulation instead of the standard-specific pattern list.

With the modulation mode MSK set, all GSM, DECT, 2FSK and other patterns with two-state modulation will be displayed. The list is displayed in alphabetical order.

PATTERN SELECT	
MULTI	NO
<ADD PATTERN>	
GSM_TSC0	
GSM_TSC1	
√GSM_TSC2	
GSM_TSC3	
GSM_TSC4	
GSM_TSC5	
GSM_TSC6	
<DOWN>	

Fig. 143 Pattern Select

IEC/IEEE bus command

```
:SENS:DDEM:SEAR:SYNC:SEL "GSM_TSC2", 3
```

MEAS ONLY
ON PAT

The *MEAS ONLY ON PATT* softkey is used to set complete measurements only if a suitable sync pattern was found.

If no burst was found, processing in the demodulator is stopped at an early stage **without further measurement results or a screen display being available**.

The analyzer is immediately ready for a new data recording and evaluation.

For averaged measurements of burst signals (BURST SRCH=ON), MEAS ONLY ON BURST should be activated so that erroneous measurements do not affect the result of averaging.

```
IEC/IEEE bus command :SENS:DDEM:SEAR:SYNC:MODE SYNC
```

Sync Patterns and Pattern Lists

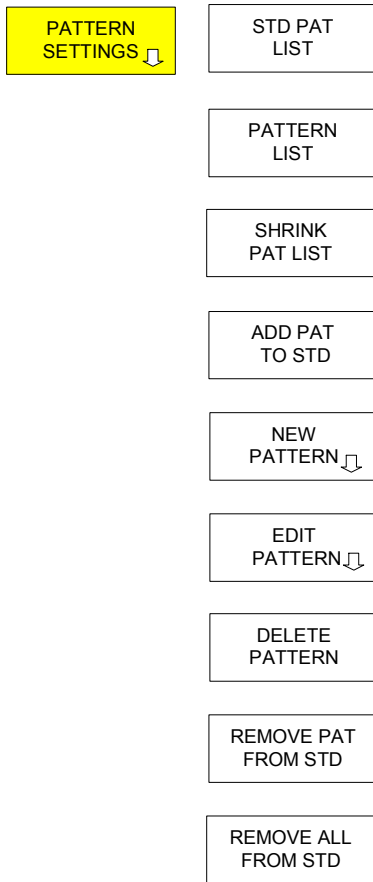

The *PATTERN SETTINGS* softkey opens a submenu for doing the following:

- managing standard-specific patterns
- creating new patterns
- editing and deleting available patterns

A table with two columns is opened at the same time. The patterns assigned to the current standard are listed in the **left** column of the table. The **right** column of the table shows an extended selection list for patterns. This selection list is used to add patterns to a digital standard and to create, edit and delete a pattern. The SHRINK / EXPAND PAT LIST softkey is used to switch between several selection levels.

PATTERN	
STANDARD: GSM_NB	ALL PATTERN
GSM_TSC0	DECT_FP
GSM_TSC1	DECT_PP
GSM_TSC2	EDGE_TSC0
GSM_TSC3	EDGE_TSC1
GSM_TSC4	EDGE_TSC2
GSM_TSC5	EDGE_TSC3
GSM_TSC6	EDGE_TSC4
GSM_TSC7	EDGE_TSC5
	EDGE_TSC6
	EDGE_TSC7
	GSM_AB0
	GSM_AB1
	GSM_AB2
	GSM_DB0
	GSM_FB0
	GSM_FB1
	GSM_SB0
	GSM_SB1
	GSM_SB2
	<DOWN>

Fig. 144 Pattern selection tables

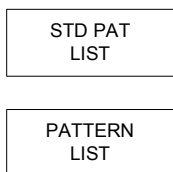

Softkeys *STD PAT LIST* and *PATTERN LIST* are used to switch the focus between the left and right column of the table. With the entry focus in the left column of the table, patterns can be edited, created or deleted from this standard list. In the right column of the table, patterns can be added to the standard list or can be deleted from the list of patterns known throughout the system.

IEC/IEEE bus commands : SENS : DDEM : SEAR : SYNC : CAT ?
 CURR
 : SENS : DDEM : SEAR : SYNC : CAT ? ALL

EXPAND
PAT LIST

SHRINK
PAT LIST

The *SHRINK / EXPAND PAT LIST* softkeys modify the right column of the PATTERN LIST table.

Three different tables are available:

- table of patterns with pattern prefix suitable for selected standard setting (PREFERRED PATTERN)
- table of patterns with degree of modulation suitable for current device settings (COMPATIBLE PATTERN)
- table of all available patterns in the device (ALL PATTERN)

The labelling and function of the softkey changes when the table is modified. To **expand** the PREFERRED PATTERN and COMPATIBLE PATTERN table, the labelling changes to EXPAND PAT LIST; when the ALL PAT table is displayed, the softkey labelling changes to SHRINK PAT LIST.

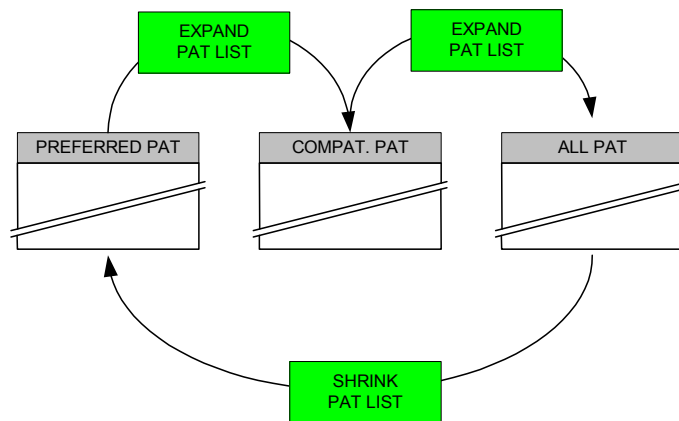

Fig. 145 Expanding pattern lists

IEC/IEEE bus command -

ADD PAT
TO STD

The *ADD PAT TO STD* softkey assigns the selected pattern of the PATTERN list (right table) to a digital standard and adds it to its list.

IEC/IEEE bus command

```
:SENS:DDEM:SEAR:SYNC:PATT:ADD "PATT_GSM"
```

DELETE
PATTERN

The *DELETE PATTERN* softkey deletes the selected pattern from the PATTERN list (right table). Any references of digital standards to this pattern are deleted as well.

IEC/IEEE bus command

```
:SENS:DDEM:SEAR:SYNC:NAME "SYNC_GSM"  
:SENS:DDEM:SEAR:SYNC:DEL
```

REMOVE PAT
FROM STD

The *REMOVE PAT FROM STD* softkey removes the selected pattern from the STANDARD list (left table). However, the pattern remains in the ALL PATTERN list and can be used again at a later time.

REMOVE ALL
FROM STD

The *REMOVE ALL FROM STD* softkey removes all patterns assigned so far to the standard from the *STANDARD PATTERN* list.

IEC/IEEE bus command

```
:SENS:DDEM:SEAR:SYNC:PATT:REM "PATT_GSM"  
:SENS:DDEM:SEAR:SYNC:PATT:REM ALL
```

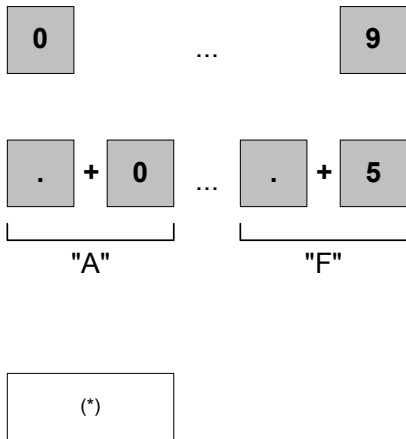
The pattern is entered into the *PATTERN SYMBOLS* table (lower part):

Before entering a pattern, you must set the logical modulation value range in the *PATTERN SETTINGS* table (*SYMBOL SPACE*). For example, the value range is 4 for QPSK, 2 for GMSK, or 32 for 32QAM.

The pattern is entered in hexadecimal notation.

After each symbol the entry has to be confirmed by pressing <ENTER> key.

The numbers 0 to 9 can be found in the usual place on the key pad. The alphanumeric characters A to F are entered by pressing the following keys:

- "."+ "0" -> A
- "."+ "1" -> B
- "."+ "2" -> C
- "."+ "3" -> D
- "."+ "4" -> E
- "."+ "5" -> F.

The (*) softkey is the wild card character for a "don't care" symbol:

This symbol is not considered when comparing the symbol data stream with the predefined patterns.

Example:

The pattern 00011011 is to be entered for a GMSK modulation.

- in table *PATTERN SETTINGS*
set parameter *SYMBOL SPACE* to 2 for the GMSK modulation
- in table *PATTERN SYMBOLS*
enter the sync pattern:
"0" <Enter>
"0" <Enter>
"0" <Enter>
"1" <Enter>
"1" <Enter>
"0" <Enter>
"1" <Enter>
"1" <Enter>
- in table *PATTERN SETTINGS*
enter name (*NAME*) and start position (*START POS*) of pattern
- save pattern using the *SAVE* softkey
- include the new pattern in the standard pattern list using the *ADD PAT TO STD* softkey.

IEC/IEEE bus command

```
:SENS:DDEM:SEAR:SYNC:NAME "SYNC_GSM"  
:SENS:DDEM:SEAR:SYNC:DATA "FFFF"
```

The *INSERT* softkey shifts the following symbols by one position and adds a "don't care" symbol to the current position.

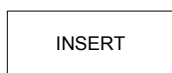

IEC/IEEE bus command -

EDIT

The *EDIT* softkey activates the overwriting mode and is used to change the symbol entries.

IEC/IEEE bus command –

DELETE

The *DELETE* softkey deletes the symbol from the selected position and moves the following symbols one position up in the list.

IEC/IEEE bus command –

SAVE

The *SAVE* softkey stores the open pattern definition under the given name and returns to the calling menu. A warning will be displayed prior to overwriting a definition with the same name.

IEC/IEEE bus command (is performed automatically for the IEC/IEEE-bus)

CANCEL

The *CANCEL* softkey stops editing without storing any data and returns to the calling menu.

IEC/IEEE bus command –

Display of Pattern in Data Stream

SYMBOL TABLE (Binary)													Pattern: EDGE_TSC0																												
00001	011	010	101	110	001	001	100	010	001	000	000	001	000	010	001	100	001	001	110	010	011	010	101	110	001	001	100	010	001	000	000	001	000	010	001	100	001	001	110	010	
00021	101	011	000	011	011	110	100	110	111	001	000	101	000	010	101	101	001	111	110	110	101	011	000	011	011	110	100	110	111	001	000	101	000	010	101	101	001	111	110	110	
00041	010	010	010	110	111	111	001	001	101	010	011	001	100	000	001	100	011	111	111	001	010	010	010	110	111	111	001	001	101	010	011	001	100	000	001	100	011	111	111	001	
00061	111	111	001	111	001	001	001	111	111	111	111	001	111	111	111	001	111	111	001	111	111	111	001	111	001	001	001	111	111	111	111	001	111	111	111	001	111	111	001	111	111
00081	001	001	001	001	010	001	101	001	011	111	110	100	010	110	001	110	101	100	101	100	001	010	001	101	001	011	111	110	100	010	110	001	110	101	100	101	100	101	100		
00101	111	100	011	111	011	101	000	001	101	011	011	011	101	100	000	101	101	011	111	010	111	100	011	111	011	101	000	001	101	011	011	011	101	100	000	101	101	011	111	010	
00121	101	010	000	001	010	010	101	111	001	011	101	110	000	001	110	011	101	001	001	111	101	010	000	001	010	010	101	111	001	011	101	110	000	001	110	011	101	001	001	111	

Fig. 147 Display of pattern in the table of decoded symbols

In the result display Symbols & Accuracy, the pattern in the symbol stream is highlighted in color on the display. On the print-out, the spattern is framed. The highlighted pattern/frame can only be seen if it is within the displayed result range. Don't care symbols are NOT highlighted in the result display. Only the **fixed components** of the sync patterns are highlighted.

Display of pattern name in function panel

A successful pattern search is additionally displayed in the function panel (PATTERN) and the name of the pattern found is displayed (e.g. GSM_TSC0). An unsuccessful search is indicated by the message "PATTERN NOT FOUND". This also applies if several patterns are searched for. If several measurements are averaged and if no update is performed, the pattern name of the last measurement will be displayed.

Setting Parameters - MODULATION SETTINGS Softkey

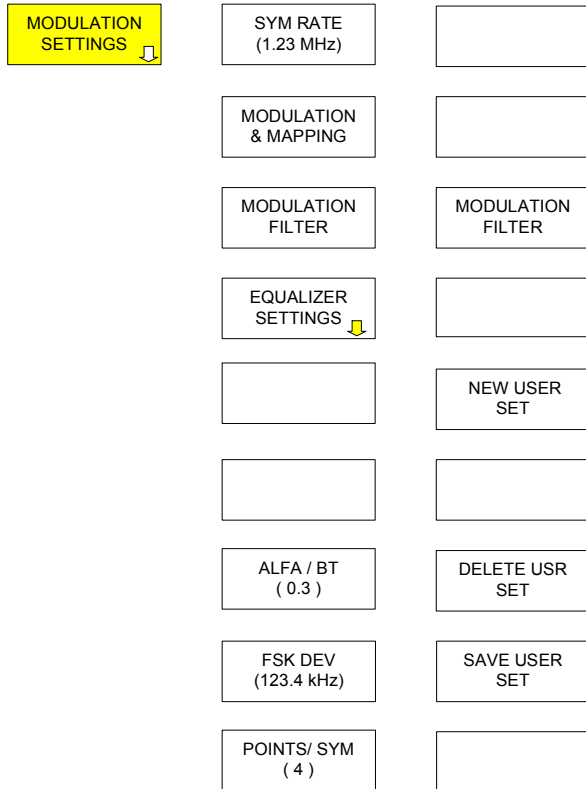

The *MODULATION SETTINGS* softkey opens a menu for setting the modulation parameters:

- symbol rate (*SYM RATE*)
- roll-off (*ALPHA BT*)
- filter (transmitter + receiver side)

MODULATION FILTER opens a table to select the standard filter setting. If a user-specific setting is available, the selection *USER* will be provided.

NEW USER SET opens a table that permits a user-specific selection of a filter set.

DELETE USER SET stores a user-defined filter set.

SAVE USER SET deletes a user-defined filter set.

- Settings for adaptive equalizer (*EQUALIZER SETTINGS*)
- Nominal deviation for FSK (*FSK DEV*)
- Modulation mode and mapping (*MODULATION & MAPPING*)
- Oversampling rate (*POINTS/SYM*)

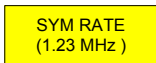

The *SYM RATE* softkey opens a window for entering the symbol rate.

The value range is 1 kHz to 25 MHz (continuous).

Together with the setting *POINTS/SYM*, the symbol rate determines the IQ bandwidth of the data recording and demodulation (see chapter 3, section "*I/Q Bandwidth*").

IEC/IEEE bus command

```
:SENS:DDEM:SRAT <num_value>
```

MODULATION & MAPPING

The MODULATION & MAPPING softkey opens a table for setting the modulation group (FSK, MSK, PSK, QAM)

- modulation mode or degree of modulation (number of modulation states)
- symbol mapping (position of logical symbol at the IQ or frequency level)

Note: An export and import function is provided for transferring predefined and user-defined standards between different instruments (see HOME VSA menu).

IEC/IEEE bus commands

```
:SENS:DDEM:FORM <modulation>

:SENS:DDEM:<modulation>:FORM <format>
:SENS:DDEM:<modulation >:NST <num_value>

:SENS:DDEM:MAPP <mapping_name>
:SENS:DDEM:MAPP:CAT?
```

The following figures show the possible modulation groups and the predefined mappings for the selected modulation mode.

MODULATION & MAPPING		
Modulation	FSK	Mapping
PSK	√2FSK * 4FSK *	√NATURAL
MSK		
QAM		
√FSK		
USER-QAM		
USB		

Fig. 148 Modulation mode FSK,-> 2FSK, 4FSK

MODULATION & MAPPING		
Modulation	MSK	Mapping
PSK	√MSK * DMSK *	√NATURAL
√MSK		
QAM		
FSK		
USER-QAM		
USB		

Fig. 149 Modulation mode MSK,-> DMSK,MSK

MODULATION & MAPPING		
Modulation	PSK	Mapping
√PSK	BPSK *	CDMA2K_FWD
MSK	√QPSK	NATURAL
QAM	DQPSK *	√WCDMA
FSK	DQPSK *	
USER-QAM	PI/4-DQPSK	
USB	8PSK *	
	D8PSK *	
	3PI/8-8PSK *	

Fig. 150 Modulation mode PSK,-> BPSK,QPSK, OQPSK, 8PSK, DQPSK, D8PSK, pi/4 DQPSK, 3pi/8-8PSK

DIGITAL DEMODULATION		
Modulation	QAM	Mapping
PSK	16QAM *	
MSK	D16QAM *	
√QAM	32QAM *	
FSK	D32QAM *	
	64QAM *	
	D64QAM *	
	128QAM *	
	D128QAM *	
	256QAM *	
	D256QAM *	

Fig. 151 Modulation mode QAM,-> 16QAM ... 256 QAM (regular, and cross structure)

MODULATION
FILTER

The *MODULATION FILTER* softkey opens a table for selecting the standard filter settings.

For detailed information on these system-theoretical filters and designs for individual filters, see chapter 3, section "*System-Theoretical Modulation and Demodulation Filters*".

MODULATION FILTER SET			
TRANSMIT FILTER	RECEIVE FILTER	MEAS FILTER	SET
RC	NONE	NONE	RC
RRC	RRC	RRC	RRC
GAUSS	NONE	NONE	GAUSS
GAUSS_LINEARIZED	EDGE_ISI	EDGE_MEAS	EDGE
CDMA2K_1X_FWD_TX	CDMA2K_1X_FWD_ISI	CDMA2K_1X_FWD_ISI	CDMA2K 1F
CDMA2K_1X_REV_TX	CDMA2K_1X_REV_ISI	CDMA2K_1X_REV_ISI	CDMA2K 1R

Fig. 152 Filter selection list

Only **complete filter sets** can be set for digital demodulation. These sets are a **combination of**:

TRANSMIT filter (= transmit filter)

RECEIVE filter (= receive filter for an ISI-free demodulation)

MEAS filter (=filter that is used for the measurement).

In many applications, the MEAS filter is identical with the RECEIVE filter. A MEAS filter is stipulated for some digital standards (e.g. EDGE).

Such a filter set is displayed in one line of the selection menu. The filter set is selected by highlighting the desired line and by pressing the ENTER key or by pressing the rollkey. The selection window will then be cleared again.

If analytic filters (RC = Raised Cosine, RRC = Root Raised Cosine, Gauss = Gaussian filter) are used, also the roll-off factor ALPHA or the bandwidth factor BT have to be given (see ALPHA/BT softkey).

The user can define, modify and delete user-specific filter sets. This will be described on the following pages.

Note: *An export and import function is provided for transferring predefined and user-defined standards between different instruments (see HOME VSA menu).*

IEC/IEEE bus commands

```
:SENS:DDEM:FILT <TX filt>, <ISI filt>,<MEAS filt>
:SENS:DDEM:FILT:CAT?
```

EQUALIZER SETTINGS

EQUALIZER ON OFF

The softkey *EQUALIZER SETTINGS* opens a menu for setting the parameters of an adaptive equalizer filter.

EQUALIZER TRAIN

A more detailed explanation of the functionality and the position in the demodulation chain can be found in the section 'Adaptive Equalizer Filter'

EQUALIZER FREEZE

EQUALIZER ON/OFF The Equalizer of the measurement demodulator is activated (ON) or deactivated (OFF).

EQUALIZER RESET

EQUALIZER TRAIN The Equalizer is set to the learning (training) mode (TRAIN)

EQUALIZER LENGTH

EQUALIZER FREEZE The Equalizer is set to the freeze mode.

EQUALIZER STEP

EQUALIZER RESET The equalizer's coefficients are preset to a neutral filter.

EQUALIZER LOAD

EQUALIZER LENGTH Selects the filter length if the adaptive equalizer

EQUALIZER SAVE

EQUALIZER STEP Selects the equalizer's learning rate

EQUALIZER DELETE

EQUALIZER LOAD Loads a previously saved filter into the workspace

EQUALIZER SAVE Saves the current filter coefficients to a file.

EQUALIZER DELETE A saved coefficient file is removed from the file list and the file is erased.

EQUALIZER ON OFF

The softkey *EQUALIZER ON/OFF* activates the adaptive equalizer filter in the signal chain. The mode of operation is controlled by the softkeys *EQUALIZER TRAIN* (learning mode on) and *EQUALIZER FREEZE* respectively (learning mode off, freeze coefficients).

If *EQUALIZER = OFF* is set, a neutral filter is displayed in any equalizer result display and switched in the demodulation chain (regardless of the equalizer was activated, trained or frozen before).

By switching on and off a frozen equalizer the instrument activates and deactivates the filter without destroying the trained filter coefficients. So the user can observe the impact of the equalizer on the modulation error displays without the need to train the equalizer again

IEC-bus-command SENS:DDEM:EQU:STAT ON | OFF

EQUALIZER TRAIN

The softkeys *EQUALIZER TRAIN* und *EQUALIZER FREEZE* control the operating mode of the equalizer.

EQUALIZER FREEZE

With *EQUALIZER TRAIN* the learning phase is started (based on the currently active filter coefficients) and –depending on the measured error vector- the filter coefficients are optimized. Due to the additional time consuming calculations the measurement rate decreases.

EQUALIZER RESET

With *EQUALIZER FREEZE* the learning phase is stopped and the coefficients are frozen. The measurement rate increases again.

With *EQUALIZER RESET* the filter coefficients are preset to a neutral filter regardless of the TRAIN or FREEZE state.

The softkeys are available only when the equalizer is switched on (*EQUALIZER ON*).

IEC-bus-commands	Train	SENS:DDEM:EQU:ADAP	ON
	Freeze	SENS:DDEM:EQU:ADAP	OFF
	Reset	SENS:DDEM:EQU:RES	

EQUALIZER LENGTH

The softkey *EQUALIZER LENGTH* activates the input of the filter length. Changing the length during operation of the equalizer is possible in principle. However, it is recommended to preset the coefficients to a neutral filter (EQUALIZER RESET) after changing the length followed by a new learning phase (EQUALIZER TRAIN). So the equalizers learning process can restart with a defined setting.

IEC bus commands `SENS:DDEM:EQU:LENG <num>`

EQUALIZER STEP

The softkey *EQUALIZER STEP* controls the equalizer's learning rate. The parameter can be altered during operation. The equalizer control unit calculates update coefficients for each block of measurement results. The currently operative coefficients are calculated with the relation:

$$coeffs(n+1) = coeffs(n) \cdot (1 - step) + update(n) \cdot step;$$

As a rule of thumb for the step settings a value of STEP = 0.1 (when started) is favourable for quick improvements of the EVM display. Later on (when improvements of the modulation error display are noticeable) a value of STEP = 0.01 or less can be used in order to get an even lower error display. When lowering the STEP values the learning rate decreases but the accuracy of the compensation increases.

IEC bus commands `SENS:DDEM:EQU:CNVR <num>`

EQUALIZER LOAD

The softkey *EQUALIZER LOAD* loads a previous saved or imported equalizer filter in the working range. The existing internal files of the selected type are listed in a table. The cursor keys or rotary knob are used to make a selection. Pressing the ENTER key as confirmation copies the file to the diskette (or to another data medium that is connected). If no matching files are found in the instrument, a blank table will be displayed. It can be exited with ESC.

IEC bus commands `SENS:DDEM:EQU:LOAD 'name'`

EQUALIZER SAVE

The softkey *EQUALIZER SAVE* allows storing of the actual equalizer coefficients in a file. A window for entering the filename is opened. Pressing the ENTER key as confirmation saves the file.

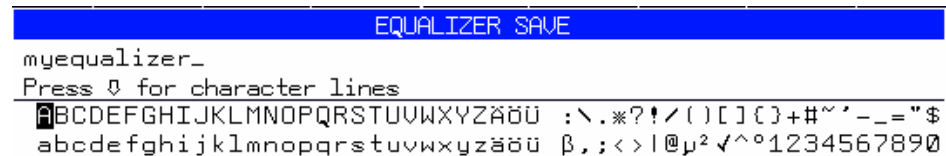

Fig. 153 Filename input

IEC bus commands `SENS:DDEM:EQU:SAVE 'name'`

EQUALIZER DELETE

The softkey *EQUALIZER DELETE* deletes a previously saved or imported equalizer filter. The existing internal files of the selected type are listed in a table. The cursor keys or rotary knob are used to make a selection. Pressing the ENTER key as confirmation deletes the file. If no matching files are found in the instrument, a blank table will be displayed. It can be exited with ESC.

IEC bus commands `SENS:DDEM:EQU:DEL 'name'`

NEW USER SET

The *NEW USER SET* softkey opens an entry window for defining a user-specific filter set. User-specific filters already available in the analyzer are offered in a selection menu.

During the import or use of individual filters, the analyzer does **NOT** check whether the filters meet the system-theoretical requirements of an ISI-free demodulation. This may be checked by the user.

If a SET is newly defined, the TX, ISI and MEAS filters must be determined one after the other from a list of all filter files.

The following figure illustrates how such a SET is created and the TX filter selected (example).



Fig. 154 Definition of a new filter set

Filter files cannot be mixed with analytical filters (RC, RRC, GAUSSIAN filters). In this case, the coefficients in the time domain must be designed for a corresponding filter and have to be imported as user-specific filters. The setting NONE is also permissible for the RECEIVE filter.

IEC/IEEE bus command -

SAVE USER SET

The *SAVE USER SET* softkey adds the newly defined *USER SET* to the modulation filter table and marks the entry as (USER) to distinguish it from the factory-set filters. If user-specific SETs are already available, new SETs are added to the end of the list. It is then returned to the *MODULATION FILTER* table.

DELETE USER SET

The *DELETE USER SET* softkey is used to delete the selected *USER SET* from the modulation filter table. If a factory-set filter set is deleted, the following error message will be displayed.

IEC/IEEE bus command -

ALFA / BT
(0.3)

The *ALFA/BT* softkey opens an entry window for the roll-off factor (PSK, QAM) or the bandwidth factor (MSK, FSK) for analytical filters.

The value range for ALFA and BT is 0.1 to 1.0.

The factor is limited for very large sampling rates. Modulation bandwidths > 28 MHz cannot occur (compensated resolution bandwidth= Comp_RBW); (R&S FSU Modulation bandwidths > 7 MHz) cannot occur; compensated RBW 7 MHz).

$$Comp_RBW \geq symbolrate * (1 + ALPHA);$$

IEC/IEEE bus command :SENS:DDEM:FILT:ALPH <num_val>

FSK DEV
(123.4 kHz)

The *FSK DEV* softkey opens a window for entering the reference deviation for FSK signals. The value range is from 1 kHz (min) to the set symbol rate (max).

Hint: For *FSK DEV* values above the set symbol rate a *POINTS/PER SYMBOL* value of at least eight is recommended.

IEC/IEEE bus commands :CALC:FSK:DEV:REF <num_value>

POINTS/SYM
(4)

The *POINTS/SYM* softkey indicates the number of samples between 2 successive symbols. The softkey also determines the signal bandwidth available for the demodulation.

Possible setting values: 1,2,4,8,16

For setting values *POINTS/SYM* <4, the internal data recording and demodulation is performed by setting "4".

IEC/IEEE bus command :SENS:DDEM:PRAT 4

Setting Demodulation - DEMOD SETTINGS Softkey

DEMOM
SETTINGS ↴

RECORD LEN
(8 kSym) ↴

RESULT LEN
(800 Sym)

EVAL
LINES ↴

MULTI
ON OFF

FORCE
WB PATH

SIDEBAND
NORM INV

NORMALIZE
ON OFF

POINTS/SYM
(4)

RECORD LEN
(8 kSym) ↴

RECORD LEN
(AUTO)

RECORD LEN
(8 kSYM)

RECORD LEN
(1.234 ms)

RECORD LEN
(AUTO)

The *DEMOM SETTINGS* softkey opens a submenu with the settings that are important for the demodulation and the display of measurement results.

RECORD LEN Indicates the size of the IQ buffer for data recording.

RESULT LEN Indicates the size of the result display.

EVAL LINES Determines the evaluation range for numeric measurement results.

EVAL LINES Determines the evaluation range for numeric measurement results.

MULTI Switches multiple evaluation mode on and off (see section "[Multiple Evaluation of a Captured Data Record \(MULTI\)](#)")

FORCE WB PATH Activates use of option "Bandwidth Extension R&S FSQ-B72" signal path below 100 MHz.

NORMALIZE Controls the conversion of the IQ offset (origin offset) into numeric results and the display format.

POINTS/SYM Indicates the number of samples between two successive symbols.

The *RECORD LEN* softkey opens a submenu for setting the size of the IQ buffer for data recording.

Time entries are internally converted into the unit symbol and are rounded to integer symbols. The screen display range of the MAG CAP BUFFERS is exclusively determined by the setting of the RECORD LEN.

The upper limit of the record length is 4194104 symbols.

The *RECORD LEN (AUTO)* softkey automatically selects the optimum setting of the record length for the corresponding device setting.

A value of 10 times the burst length is set for a digital standard. If no bursts are defined in the standard, a value of 10 times the *RESULT LEN* is set.

IEC/IEEE bus command
:SENS:DDEM:RLEN:AUTO ON

RECORD LEN
(8 kSYM)

The *RECORD LEN (x SYM)* softkey activates the entry of the record length in symbols.

At least double the value of RESULT LEN should be set.

IEC/IEEE bus command

:SENS:DDEM:RLEN <num>SYM

RECORD LEN
(1.234 ms)

The *RECORD LEN (x sec)* softkey activates the entry of the record length in seconds.

At least double the value of RESULT LEN should be set.

IEC/IEEE bus command

:SENS:DDEM:RLEN <num>S

RESULT LEN
(8 kSym)

The *RESULT LEN* softkey opens a window for entering the maximum display range on the display of the analyzer. This display range is principally valid for all result displays.

The result range will be limited to the range determined by *EVAL LINES* only for the results in

MODULATION ACCURACY,
SPECTRUM or *ERROR SPECTRUM* and
STATISTIC or *ERROR STATISTIC*

See section "[Evaluation Lines / Limiting the Measurement Range](#)".

IEC/IEEE bus command :SENS:DDEM:TIME <num_value>

MULTI
ON OFF



The *MULTI ON/OFF* softkey switches **multiple evaluation mode** on and off ("[Multiple Evaluation of a Captured Data Record \(MULTI\)](#)").

If MULTI ON is selected, a new capture is performed once the end of the record buffer has been reached. Otherwise, the message '**End of Buffer**' will be output.

IEC/IEEE-bus command: :SENS:DDEM:SEAR:MBUR ON

FORCE
WB PATH



(R&S FSQ only)

The *FORCE WB PATH* softkey activates the use of signal path of option "Bandwidth Extension R&S FSQ-B72" for symbol rates below 25 MHz.

This softkey is only available, if option "Bandwidth Extension R&S FSQ-B72" is installed. This option is automatically activated when using sample rates above 100 MHz (= symbol rate 25 MHz * 5 points/symbol).

If function *FORCE WB PATH* is switched on the B72 signal path is also used for sample rate below 25 MHz.

The softkey is available down to symbol rate 5.1 MHz (at 4 points/symbol). Reducing the symbol rate below 5.1 MHz will automatically switch off this function.

SIDEBAND
NORM INV

IEC/IEEE-bus command: `SENS:DDEM:WBAN:STAT ON|OFF`

The *SIDEBAND NORM/INV* softkey switches between spectral non-inverted and inverted position.

NORM The demodulator operates in non-inverted position.

INV The demodulator expects the spectral inverted position at the input.

IEC/IEEE bus command : `SENS:DDEM:SBAN NORM | INV`

NORMALIZE
ON OFF

The *NORMALIZE ON/OFF* softkey activates/deactivates the normalization.

ON The measured value evaluated for the IQ offset (origin Offset), for the display format and further error calculations (EVM, phase error ...) is subtracted from the IQ measurement data record.

OFF The error calculations are performed using the uncorrected data record. This setting is useful for the measurement of non-linear distortion.

IEC/IEEE bus command : `SENS:DDEM:NORM ON | OFF`

POINTS/SYM
(4)

The *POINTS/SYM* softkey sets the number of reference points between two symbol points in time.

The setting range is 1;2;4;8;16.

The IQ data recording is always performed with a minimum of 4 *POINTS/SYM* and does not depend on the setting range. For setting values 1;2, data is reduced only if the results are displayed.

The parameter has a special effect on the bandwidth of the data in the RECORD BUFFER (IQ bandwidth); for further examples, see "[Bandwidths for Signal Processing](#)".

IEC/IEEE bus command : `SENS:DDEM:PRAT 4`

Evaluation Lines / Limiting the Measurement Range

The evaluation lines limit the evaluation range of numeric error displays in the *MODULATION ERRORS* mode.

For modulation modes PSK, MSK and QAM, this applies to:

- EVM
- phase error
- RHO
- frequency error (only MSK)

For the modulation mode FSK, this applies to error displays for:

- magnitude error
- frequency error

To obtain stable demodulation, the analyzer uses - irrespective of the very tightly set evaluation lines - a large demodulation range. For burst signals, this corresponds to the "Useful Length". For unburst signals, it corresponds to the "Result Length".

Within this extended range, further numeric error displays such as the following are determined:

- center frequency error
- IQ offset (origin offset)
- IQ imbalance

The following figure shows different predefined setting options using a burst signal as an example. The *EVAL RANGE* can also be determined by manually positioning *EVAL LINE 1* or *EVAL LINE 2*.

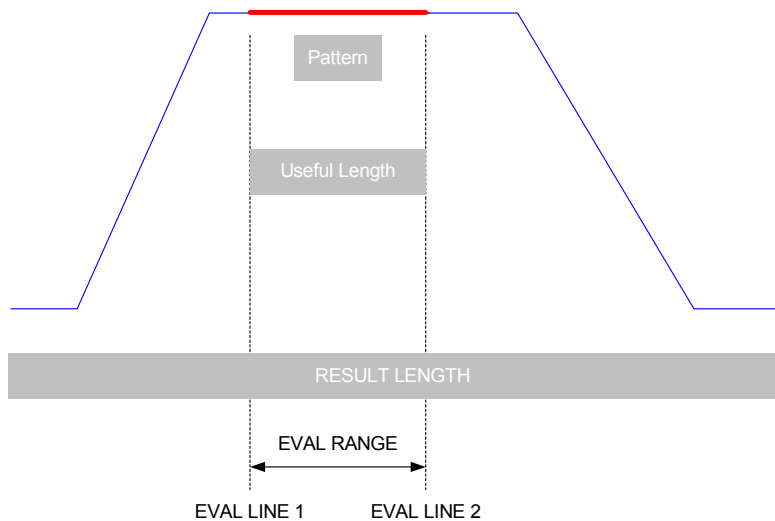
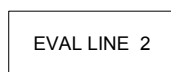
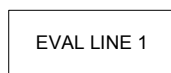
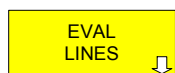

Fig. 155 Setting the *EVAL RANGE*



⋮

The *EVAL LINES* softkey opens a submenu for setting the evaluation ranges for a measurement.

EVAL LINE 1/2 Selects the left and right margin of the range.

IEC/IEEE bus commands :CALC:ELIN1 2SYMB
 :CALC:ELIN2 12SYMB
 :CALC:ELIN:STAT ON | OFF

Record Buffer, Demodulation Range and Display Range

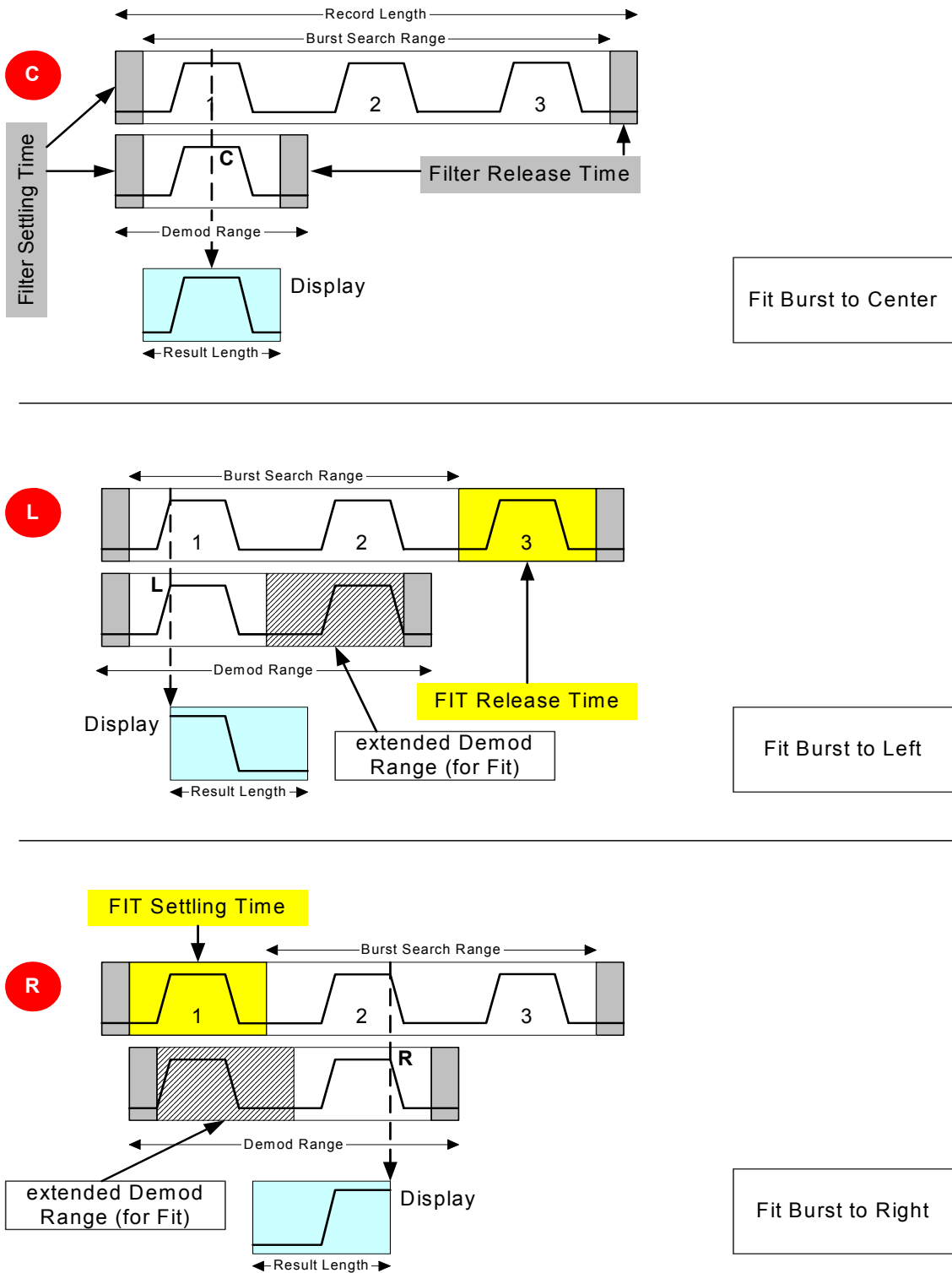

Fig. 156 Record buffer burst search range and result display

The operating settings for screen positioning (section "[Positioning of Display on Screen - FIT TRACE Softkey](#)") also determine internal processing lengths and search ranges within the record buffer. The analyzer may limit search ranges since the operating settings for screen positioning have priority.

Fig. 156 shows three examples of different screen positioning that display record buffer demodulation range in signal processing and the result display with the set display positioning

The operating parameter *RESULT LENGTH* determines the length of the result display. The operating parameter *FIT BURST* is used to control the position of the burst on the screen. The evaluation range of the modulation parameters (see section Burst and Search Parameters) is, in every example, limited to the burst length (the inner burst range). The parameters evaluated there (center frequency error, symbol timing) are applied to the complete data record of signal processing (in this case designated as DSP_Demod_Range).

The data range of the record buffer considered in this DSP_Demod_Range is evaluated by the analyzer based on the burst length and the operating parameters *RESULT LEN* and *FIT*. In addition to the actual processing length, settling ranges are required for filtering and demodulation. They are displayed in grey. Further settling times (*FIT Settling / Release Time*) are required for correct representation and are displayed in light grey.

C FIT BURST to CENTER

Burst_1 is recognized with this setting. It is positioned in the center of the burst representation. The simple *RESULT LENGTH* which is extended at the margin of the screen by settling ranges is sufficient as the processing range (DSP_Demod Range). FIT BURST to CENTER shows the typical default setup for digital standards.

L FIT BURST to LEFT

This setting is used to recognize Burst_1, and the left edge of the burst is positioned to the left margin of the screen. The processing range (DSP_Demod Range) is extended towards the right since an **extended right edge** is required for burst representation. In Fig. 156, this is shown by a doubled DSP-Demod_Range. The analyzer calculates the actually required length itself.

R FIT BURST to RIGHT

This setting is used to position the right edge of the burst to the right margin of the screen. The processing range (DSP_Demod Range) starts at a later time since an **extended left edge** is required for the representation. As a result of the limitation of the search range, the measurement is performed only with the second burst in the record buffer. When an external trigger is used, a modification of the FIT settings must be compensated for by adapting the trigger delay setting. This is done to record data prior to burst_1.

For further positioning options, see section *FIT TRACE*. The same interdependencies apply.

Display of Measurement Results

Spectral Displays

Spectral evaluations can be carried out for all result displays that show the time or symbols on the x axis.

- Meas and Reference Signal: Magnitude, Phase, Frequency, Real/Imag
- Error Signal: Error Magnitude, Error Phase, Error Frequency, Error Real/Imag, EVM
- Capture Buffer: Magnitude Capture Buffer, Frequency, Real/Imag.

An I/Q mapper maps logic symbols onto real Dirac pulses. For real input signals, the spectrum between the frequencies 0 and (symbol rate*points/symbol/2) is displayed; for complex input signals (REAL/IMAG and Error REAL/IMAG), the spectrum between +/- (symbol rate*points/symbol/2) is displayed.

The input signal is subjected to a fast Fourier transform (FFT) with 4096 points, and the magnitude is calculated and displayed. If the basic result display is too long, the total length is divided into several subblocks of 4096 points each and the results are averaged. The subblocks overlap each other by 25% of the block length. In addition, the input signal or the subblocks are evaluated with a FLATTOP window.

If TimeLines for restricting the evaluation area are active, the FLATTOP window is also restricted to the area inside the TimeLines. Following the FFT, the spectrum magnitude is calculated and displayed.

Fig. 157 and Fig. 158 show examples of such spectral evaluations. The upper trace shows the basic diagram in each case, while the lower trace shows the associated spectral evaluations.

The top part of Fig. 157 shows EVM versus time; the FFT magnitude versus the EVM signal is shown at the bottom. In Fig. 158, the FFT is applied to the complex signal (REAL/IMAG, top). The bottom diagram shows the FFT magnitude. Since the input signal was complex, a two-sided spectrum is shown. In both cases, the time range for the FFT is restricted by the activated TimeLines so that, for example, burst edges will not be included.

When activating the spectral display, the measurement evaluation must first be set in the time range in order to then switch the display over by pressing the SPECTRUM softkey. The scaling and the unit of the x axis of the basic diagram are also used on the y axis of the spectrum display but they can be changed via the RANGE menu. The LIN/LOG softkey in this menu can be used to switch between linear and logarithmic scaling of the y axis.

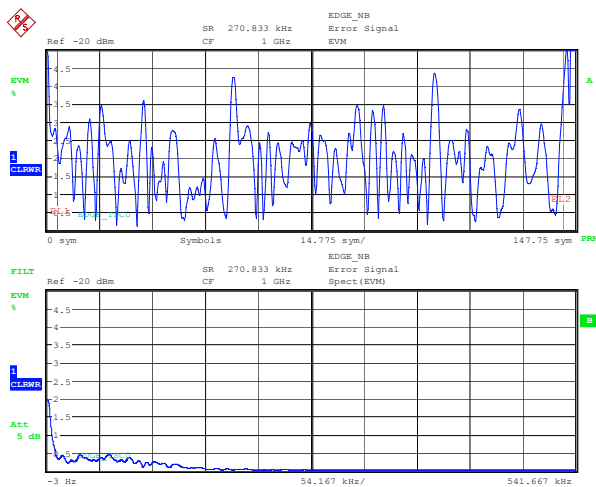

Fig. 157 Spectrum diagram: Single-sided display for real input signals

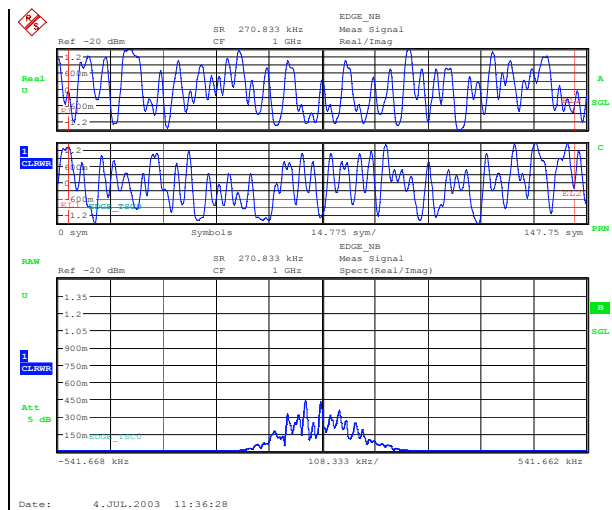

Fig. 158 Spectrum diagram: Two-sided display for complex input signals

Statistical Displays

Statistical evaluations can be carried out for all result displays that show the time or symbols on the x axis.

Measurement and Reference Signal: Magnitude, Phase, Frequency, Real/Imag

Error Signal: Error Magnitude, Error Phase, Error Frequency, Error Real/Imag, EVM

Capture Buffer: Magnitude Capture Buffer, Frequency, Real/Imag.

For complex displays (REAL/IMAG and Error REAL/IMAG), a separate statistics diagram is calculated for the real and imaginary parts.

The input signal of the basic display is quantized and the probability of occurrence is shown by a bargraph. Probabilities of occurrence located outside the display area are applied to the bars at the left or right borders of the display. The quantization can be set via the number of bars in the display area by using the RANGE -> QUANTIZE parameter. In the basic setting, 101 bars are used.

Fig. 159 shows an example of a statistical evaluation. The upper trace shows the basic diagram (EVM), while the lower trace shows the associated distribution of the EVM. As with spectral displays, the time range for evaluation is also restricted by means of the activated TimeLines so that, for example, burst edges will not be included.

When activating statistical evaluation, the measurement evaluation must first be set in the time range in order to then switch the display over by pressing the STATISTIC or ERROR STATISTIC softkey. The scaling and the unit of the y axis of the basic diagram are also used on the x axis of the statistics display but they can be changed via the RANGE menu. The RANGE -> LIN/LOG softkey in this menu can be used to switch between linear and logarithmic scaling of the y axis.

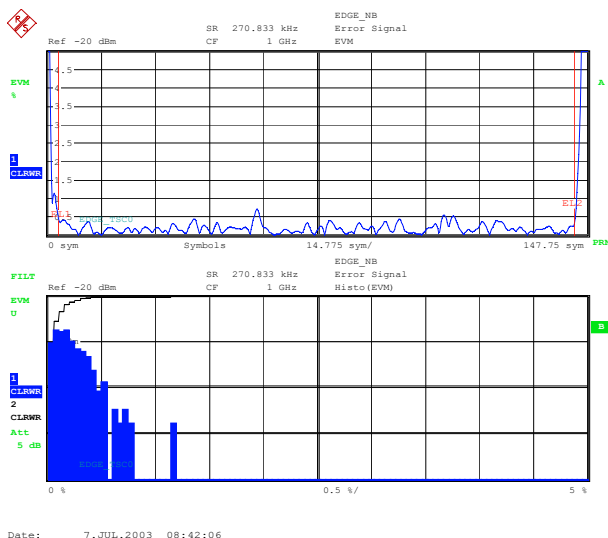
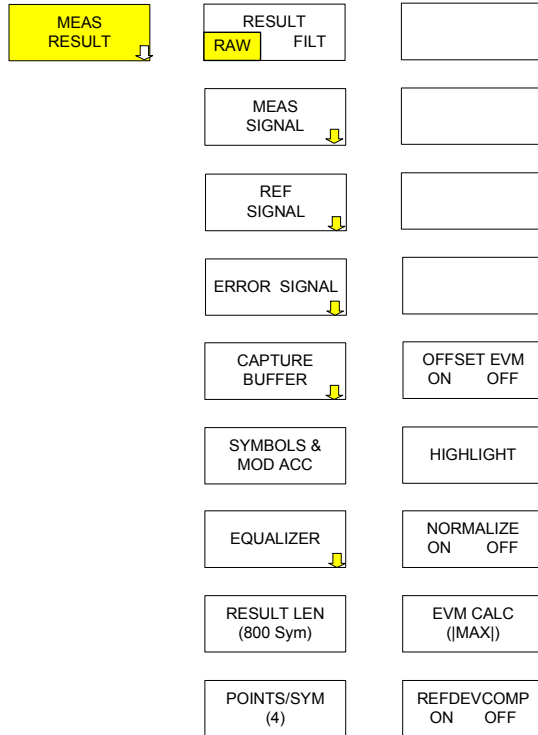

Fig. 159 Error vector magnitude (top) EVM frequency distribution (bottom)

MEAS RESULT Softkey



The *MEAS RESULT* softkey opens a menu for selecting result displays.

- RESULT RAW/ FILT* Selects the measurement on an unfiltered raw signal or a filtered signal.
- MEAS SIGNAL* Opens a submenu for selecting the measurement signal (*MEASUREMENT SIGNAL*).
- REF SIGNAL* Opens a submenu for selecting the reference signal (*REFERENCE SIGNAL*).
- ERROR SIGNAL* Opens a submenu for selecting the modulation error display.
- CAPTURE BUFFER* Opens a submenu for selecting the recorded raw signal.
- SYMBOLS & MOD ACC* Outputs the decoded symbols as well as numeric modulation errors. (*MODULATION ACCURACY*)
- EQUALIZER* Opens a submenu for selecting the filter coefficient display or related displays of the adaptive equalizer
- OFFSET EVM ON/OFF* Influences the calculation of the error vector magnitude trace for Offset-QPSK only.
- HIGHLIGHT* Highlights the symbol decision instants in many diagrams.
- REFDEVCOMP* Controls the normalization of the FSK reference signal to the measurement signal.
- EVM CALC* Selects the calculation method for error calculation and display of error vector magnitude..

The function and operation of the following softkeys are identical to the softkeys in the *DEMOD SETTINGS* menu

- *RESULT LEN*
- *NORMALIZE*
- *POINTS/SYM*

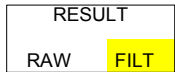

The *RESULT RAW/FILT* softkey selects between filtered and unfiltered signals.

FILT

In many mobile radio systems, the filtering between the transmitter and the receiver is defined in such a way that intersymbol interference-free sampling times are available in the receiver. This operating mode is attained with the setting *RESULT FILT*.

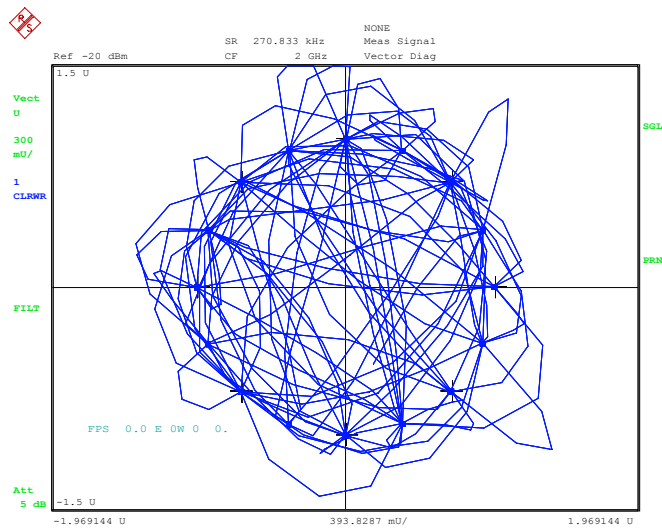

RAW

For further applications (e.g. distortion measurement on transmitter output stages), demodulated but unfiltered measurement signals that are not falsified by filtering in the receiver are required.

With the setting *RESULT RAW*, demodulation is continued down to the symbol level. Then, a reference signal is generated again. This signal corresponds to an **unfiltered raw signal** and further evaluations are performed with these raw signals.

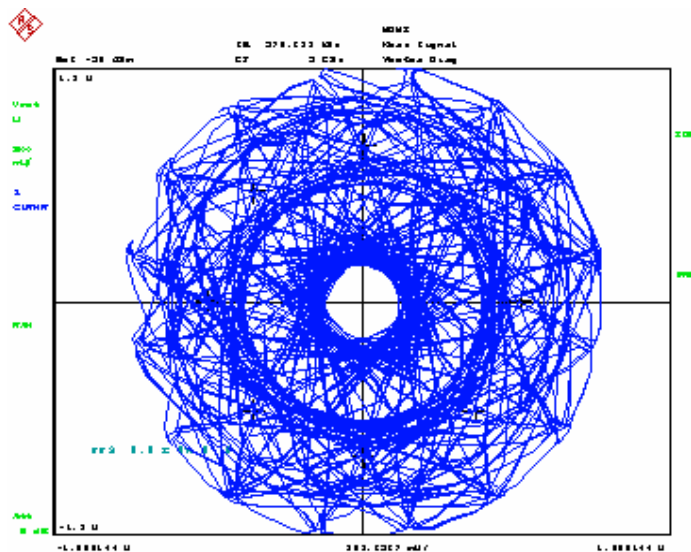

Note:

Constellation diagrams for which the measurement points are concentrated at the ideal symbol points of the I/Q diagram normally do not occur in display modes that are derived from *RESULT RAW*. This is due to the fact that filtering in the receiver

resulting in intersymbol interference-free (ISI-free) times is not performed.

This softkey **is not available** in MSK and FSK systems since the demodulation is always carried out with unfiltered signals.

IEC/IEEE bus command :SENS:DDEM:FILT:STAT ON | OFF



See section "Selection of Displayed Measurement and Reference Signal - MEAS SIGNAL / REF SIGNAL Softkey."

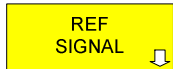

See section "Selection of Error Display - ERROR SIGNAL Softkey"



See section "Selection of the Raw Signal - CAPTURE BUFFER Softkey"

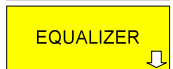

See section "Selection of Adaptive Equalizer Display - EQUALIZER Softkey"

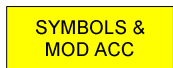

The SYMBOLS & MOD ACC softkey activates the display of numeric results (MODULATION ACCURACY) and the table of decoded symbols.

In the display mode **Single Screen**, the decoded symbols are displayed in the upper part and the numeric result values in the lower part of the table (see Fig. 160).

With TRACE AVERAGE = ON, further statistical evaluations (RMS, AVG, Standard Deviation, Total Peak) for the previous sweeps are displayed in addition to the numeric results for the current sweep (see also Fig. 161).

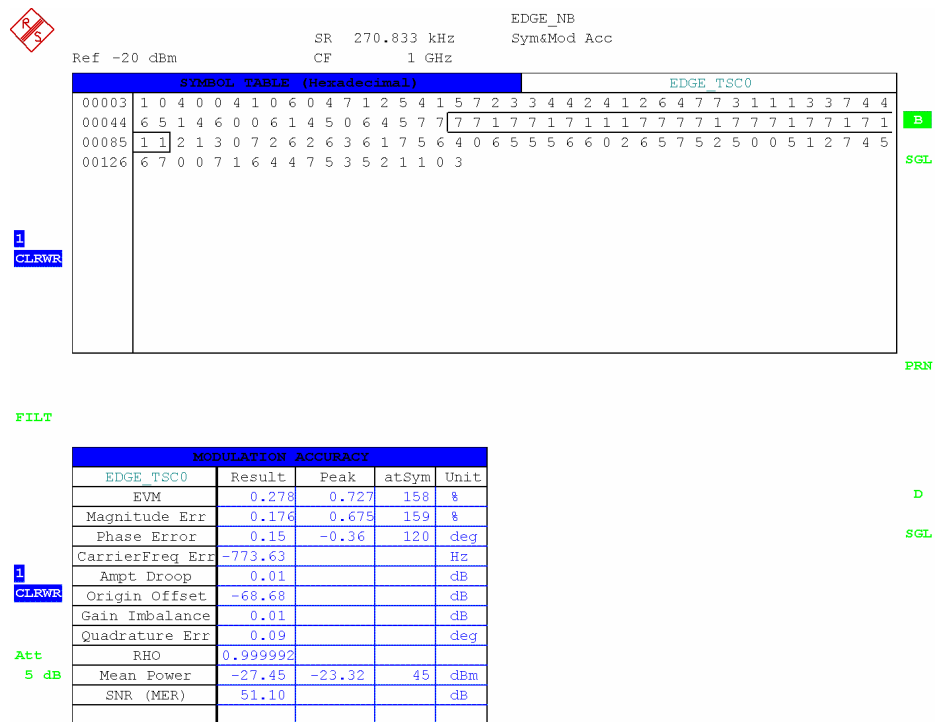



Fig. 160 Modulation Accuracy (single screen, Trace Average = off)

IEC/IEEE bus command : CALC:FEED "TCAP"
 IEC/IEEE bus commands : CALC:FEED "XTIM:DDEM:SYMB"
 : CALC:MARK:FUNC:DDEM:STAT:EVM? AVG
 (general : CALC:MARK:FUNC:DDEM:STAT:<result>? <type>
 see "Table of Softkeys Assigned to IEC/IEEE Bus Commands")



Ref -20 dBm SR 270.833 kHz CF 1 GHz EDGE_NB
 SymsMod Acc

SYMBOL TABLE (Hexadecimal)										EDGE_TSC0																																	
00003	6	6	7	3	0	1	3	2	7	6	5	2	4	0	2	4	5	3	6	2	7	3	4	0	3	4	7	2	2	3	6	5	6	5	0	4	4	1	4	7	0		
00044	2	7	5	5	4	6	4	1	6	7	4	1	7	7	6	0	3	7	7	1	7	7	1	7	1	1	1	7	7	7	1	7	7	7	1	7	7	1	7	7	1	7	1
00085	1	1	6	7	6	1	3	4	6	2	0	2	2	4	7	3	2	1	7	1	7	4	6	6	1	2	4	4	3	4	3	3	2	5	6	1	1	4	2	1	0		
00126	0	1	0	2	1	4	1	1	6	2	5	3	0	3	3	6	4	6																									

1 AVG

PRN

FILT

MODULATION ACCURACY (AVERAGE)										
EDGE_TSC0	Current Sweep			Statistic Count 10 of 0 (std AVG)						
	Result	Peak	atSym	RMS	AVG	StdDev	95pctl	Total Pk	Unit	
EVM	0.223	0.608	90	0.239	0.208	0.123	0.439	1.243	%	
Magnitude Err	0.178	0.482	48	0.161	0.129	0.096		1.021	%	
Phase Error	0.34	-3.37	77	0.24	-0.00	0.24		-6.23	deg	
CarrierFreq Err	-774.13			774.13	-774.13	775.36m		-776.87	Hz	
Ampt Droop	0.02			0.02	0.02	0.01			dB	
Origin Offset	-59.89			-61.73	-62.11	3.26			dB	
Gain Imbalance	-0.00			-0.00	-0.00	0.00			dB	
Quadrature Err	-0.02			0.05	-0.00	0.05			deg	
RHO	0.999995			0.999994	0.999994	0.000001				
Mean Power	-27.48	-23.38	72	-27.72	-28.43	5.36		-23.09	dBm	
SNR (MER)	53.05			52.45	53.77	58.24	47.15	1.24	dB	

1 AVG

Att 5 dB

D

Date: 11.AUG.2003 09:35:03

Fig. 161 Modulation Accuracy (single screen, Trace Average = off)

In the display mode **Split Screen**, either the information of the Modulation Accuracy representation or the table of decoded symbols is displayed. Switching between these two display modes is done via hotkey A/B (upper half of split screen) or C/D (lower half of split screen).

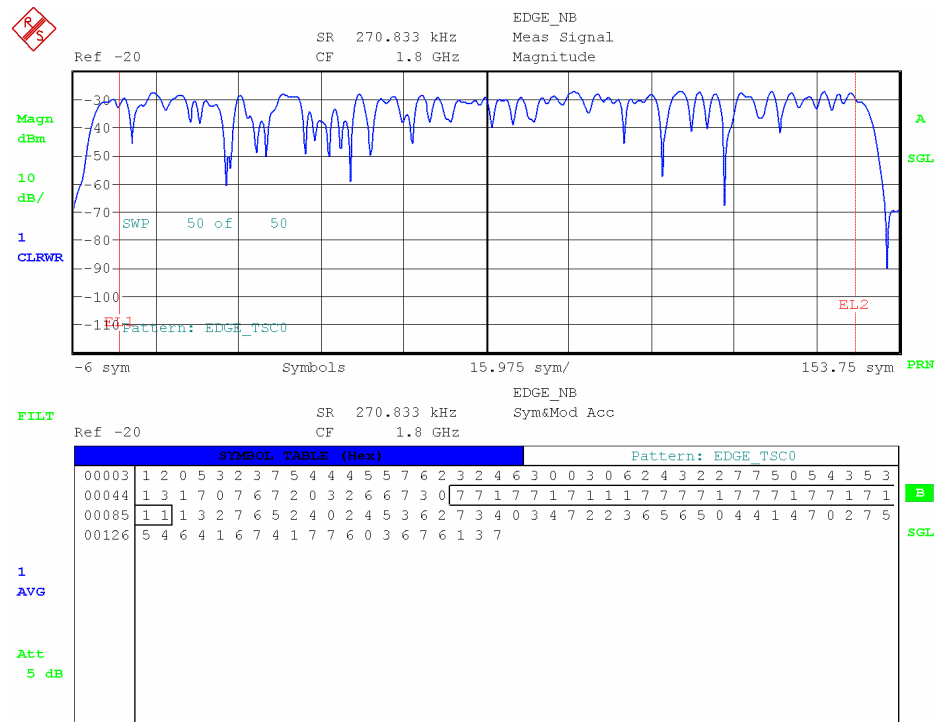

Date: 19.DEC.2002 13:00:00

Fig. 162 Modulation Accuracy (split screen, Trace Average = on), indication of decoded symbols

RESULT LEN
(800 Sym)

NORMALIZE
ON OFF

POINTS/SYM
(4)

OFFSET EVM
ON OFF

The function of these softkeys is identical with the softkey of the same name in section "[Setting Demodulation - DEMOD SETTINGS Softkey](#)".

The *OFFSET EVM ON/OFF* softkey influences the calculation of the error vector magnitude trace for Offset-QPSK only. It has no effect for all other modulations. It has no effect on results based on the MEAS or the REF signal. At which samples will the difference between MEAS and REF signal be measured:

- *OFFSET EVM ON*: The error vector magnitude is calculated at the symbol instants of the I-part and the symbol instants of the Q-part of the Offset-QPSK signal. In other words: The half symbol duration delay of the Q-part is compensated. In firmware versions prior to the introduction of this softkey, this was method was always used for Offset-QPSK.
- *OFFSET EVM OFF*: The error vector magnitude is calculated at the symbol instants of the I-part and the corresponding sample of the Q-part of the signal. But the latter is not a symbol instant. In other words: The Offset-QPSK signal is treated like a QPSK signal for the error vector magnitude calculation, the Q-delay is not compensated.

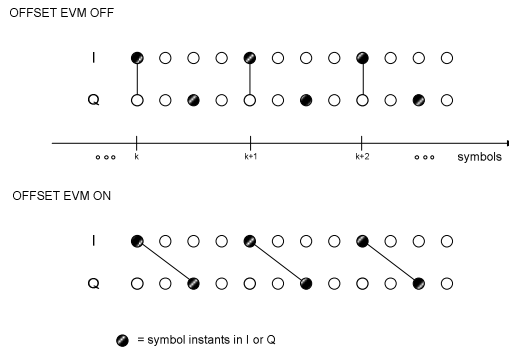

Example how samples are selected depending on “OFFSET EVM ON/OFF” (shown for oversampling 4).

This softkey does not only influence the way how the difference between the MEAS and the REF signal is calculated (Numerator of the EVM formula). If the softkey “EVM CALC” is not set to “MAX SYMBOL”, but to “SIGNAL MEAN POWER”, the calculation of the normalization factor C (denominator of the EVM formula) is also switched to work in the same fashion. So the half symbol duration delay of the Q-part of the REF signal is either compensated or not.

This normalization factor C is not only used for EVM-based results, but also in the SNR (MER) calculation.

So in the case of Offset-QPSK this softkey “OFFSET EVM ON/OFF” has an effect on all these results:

- Error vector magnitude (EVM) trace
- All the numerical EVM results in the *Modulation Accuracy* table. Therefore the EVM in the table is either titled “EVM offset” or “EVM no offset”.
- The SNR (MER) in the *Modulation Accuracy* table, because of the changing normalization factor C.

Note: The EVM result in the *Modulation Accuracy* table is listed as “EVM Offset” and “EVM No Offset” respectively.

IEC/IEEE bus command :SENS:DDEM_ECAL:OFFS ON | OFF

HIGHLIGHT

The **HIGHLIGHT** softkey highlights the symbol points in time using a square (see “Fig. 181”).

REFDEVCOMP
ON OFF

The **REFDEVCOMP ON/OFF** softkey switches the method for calculating the frequency error for FSK modulation between the following:

ON Scales the reference signal to the actual deviation of the measurement signal.

OFF Uses the entered nominal deviation for the reference signal.

IEC/IEEE bus command :CALC:FSK:DEV:COMP ON | OFF

EVM CALC
(MAX SYM)

The **EVM CALC** softkey switches the calculation formula for EVM between:

MAX SYM PWR Selects the traditional EVM formula and normalizes the difference between the MEAS and REF vectors to the square root of the power of the symbol with the highest magnitude.

EVM CALC
(MEAN PWR)

MEAN PWR Normalizes the difference to the square root of the average signal power in the considered period of time. This method is used for the digital standard EDGE, for example.

These settings affect **only** the display of *EVM* as a function of time and the display of *RMS-EVM* in the modulation summary (see also section 9 "[Glossary and Formulae](#)").

IEC/IEEE bus command: SENS:DDEM:ECAL SYMB | SIGN

Selection of Displayed Measurement and Reference Signal - MEAS SIGNAL / REF SIGNAL Softkey

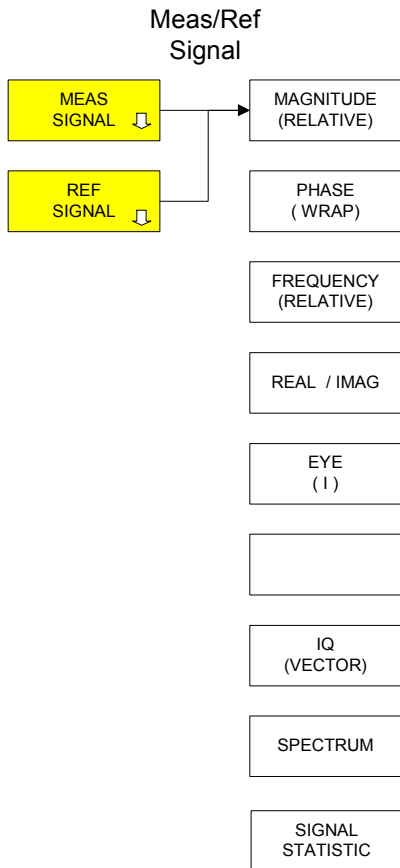

The softkeys *MEAS SIGNAL* and *REF SIGNAL* open further submenus for selecting the desired measurement result. The submenu is identical for both softkeys.

The following result displays can be selected:

The following **quantities** can be displayed **as a function of time**:

- MAGNITUDE* Magnitude of IQ data set
- PHASE* Phase or argument of IQ data record
- FREQUENCY* Frequency characteristic
- REAL/IMAG* Inphase and quadrature component

Display in the IQ plane

IQ IQ display

Display of derived quantities:

- SPECTRUM* Spectral evaluations
- SIGNAL STATISTIC* Statistical evaluations

The display modes:

- FREQUENCY* Available only for MSK and FSK
- REAL/IMAG*, *EYE* and *IQ*
Available only for PSK, MSK and QAM

IEC/IEEE bus command

```
:CALC:FEED 'XTIM:DDEM:MEAS '  
:CALC:FEED 'XTIM:DDEM:REF '
```

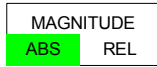

The *MAGNITUDE* softkey sets the result display to show the magnitude of the measurement or reference signal.

ABS The actual signal amplitude is displayed.

REL The signal amplitude is scaled to the ideal reference signal and is relative to the unit circle of the symbol mapping (see *IQ VECTOR* or *IQ CONSTELLATION* display).

$$MAG_MEAS(n) = |MEAS(n)|;$$

or

$$MAG_REF(n) = |REF(n)|$$

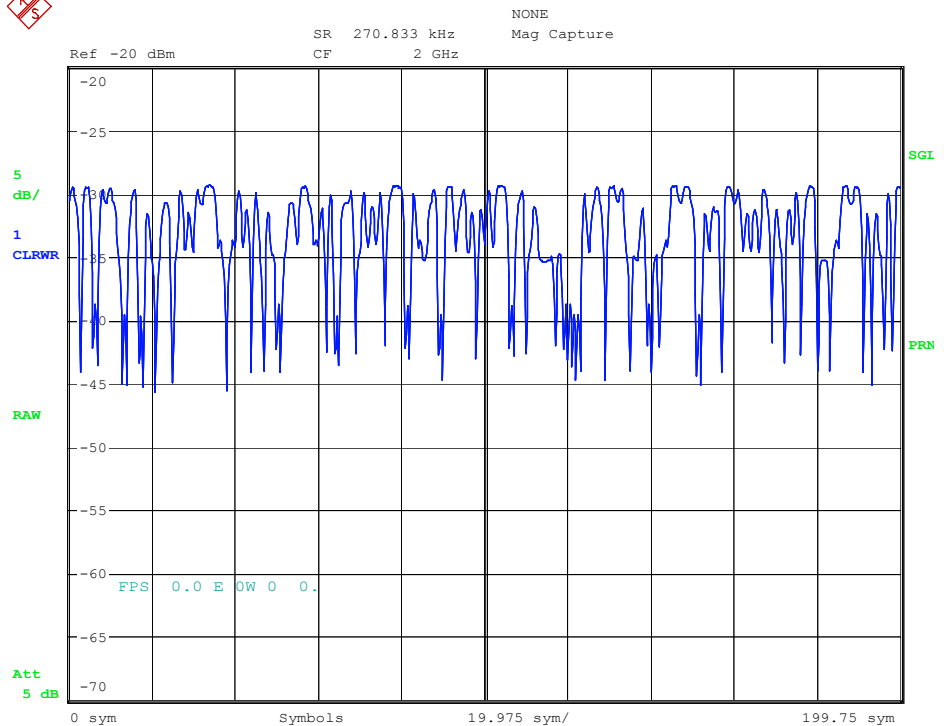

Date: 16.OCT.2002 12:59:32

Fig. 163 Result display *MAGNITUDE*

```
IEC/IEEE bus commands : CALC:FEED 'XTIM:DDEM:MEAS'
                        : CALC:FORM MAGN
                        : DISP:WIND:TRAC:Y:SCAL:MODE ABS | REL
```

PHASE
UNWR WRAP

The *PHASE* softkey sets the result display to show the PHASE of the measurement or reference signal.

$$PHASE_MEAS(n) = \angle MEAS(n);$$

or

$$PHASE_REF(n) = \angle REF(n);$$

WRAP The display is limited to the value range of 2pi.

UNWRAP Also phase characteristics >2pi can be displayed.

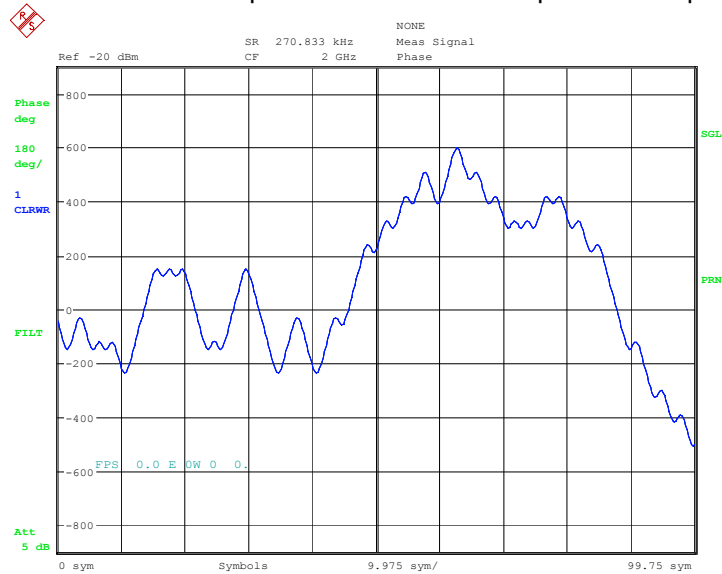

Date: 16.OCT.2002 13:19:29

Fig. 164 Result display *PHASE* (UNWRAP)

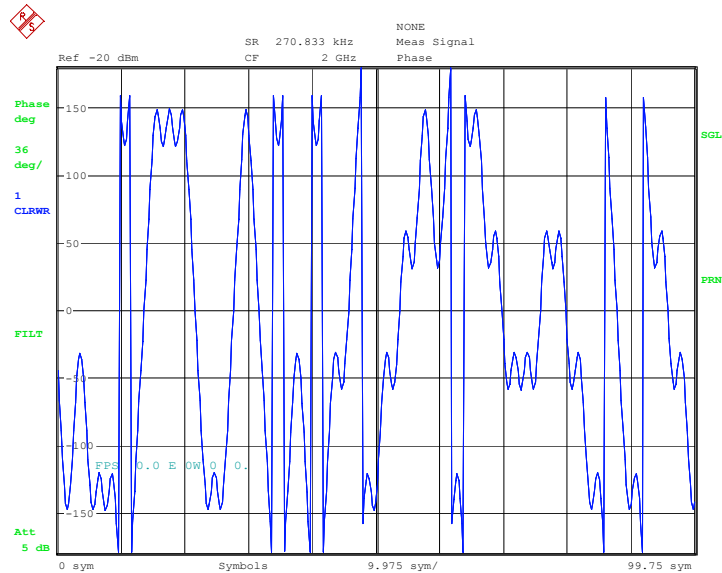

Date: 16.OCT.2002 13:19:53

Fig. 165 Result display *PHASE* (WRAP)

IEC/IEEE bus commands :CALC:FEED 'XTIM:DDEM:MEAS'
:CALC:FORM PHAS | UPH

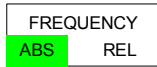

The *FREQUENCY ABS /REL* softkey sets the result display to show the current frequency of the measurement or reference signal.

The display of the current frequency is possible only for modulation modes FSK and MSK. It can either be normalized to the set reference deviation (*RELATIVE*) or performed with absolute axial scaling (*ABSOLUTE*).

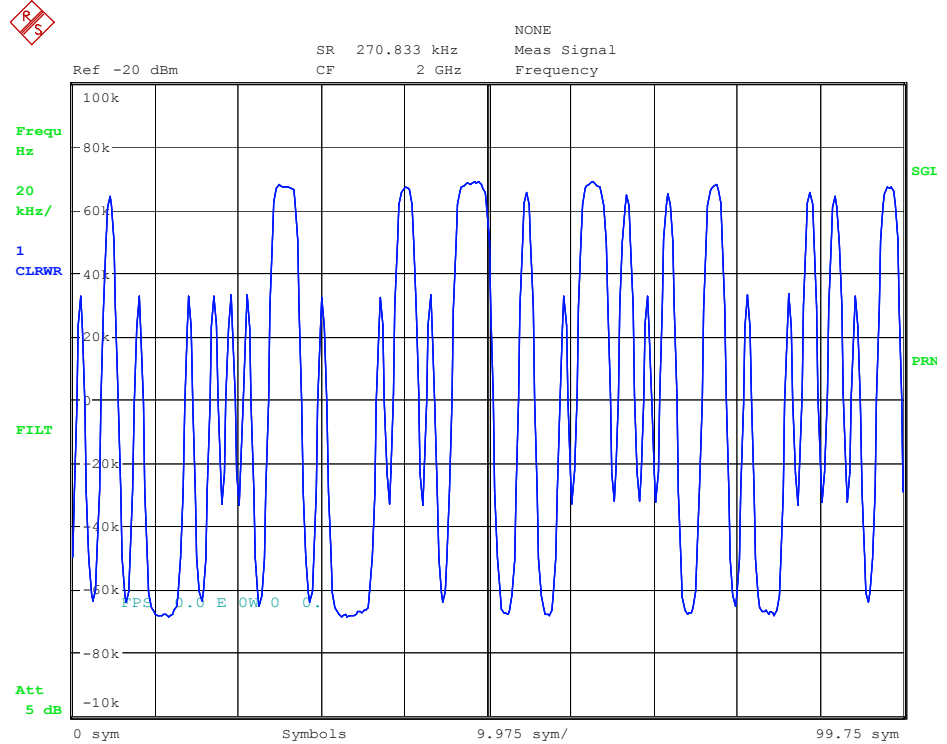

Date: 16.OCT.2002 13:18:17

Fig. 166 Result display *FREQUENCY (ABS)*

```
IEC/IEEE bus commands :CALC:FEED 'XTIM:DDEM:MEAS'
                       :CALC:FORM FREQ
                       :DISP:WIND:TRAC:Y:SCAL:MODE ABS | REL
```

REAL/IMAG

The *REAL/IMAG* softkey activates the representation of the real and imaginary part of the measurement or reference signal in separate measurement diagrams. The x axis (scaled in time units or symbols) is identical for both diagrams.

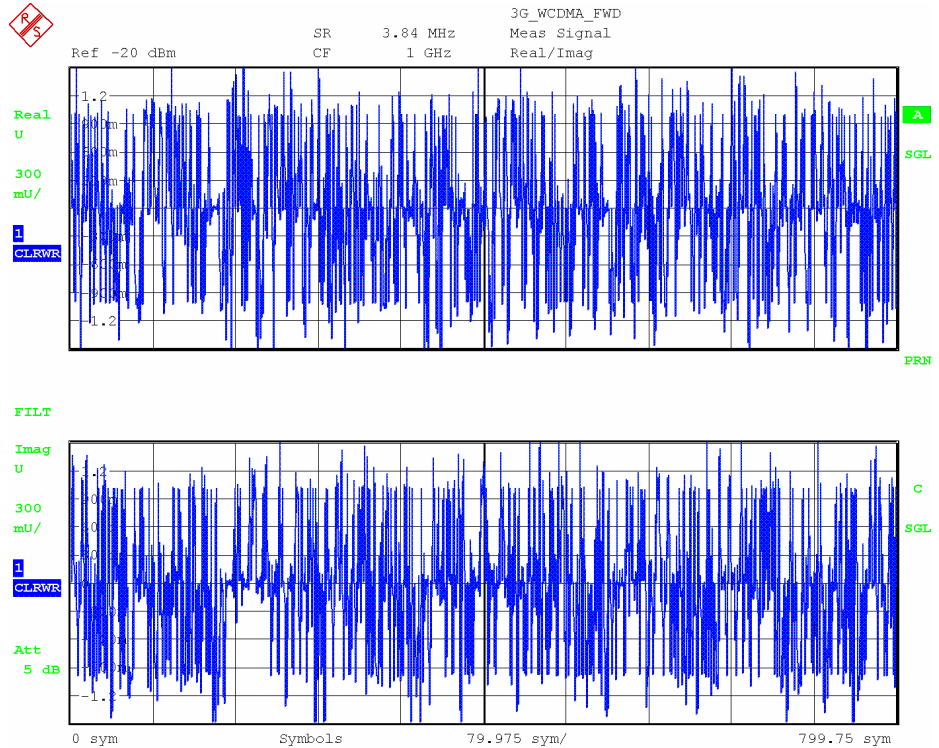

Date: 11.AUG.2003 09:26:08

Fig. 167 Result display REAL/IMAG

IEC/IEEE bus commands :CALC:FEED 'XTIM:DDEM:MEAS'
:CALC:FORM RIM

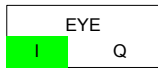

The *EYE I/Q* softkey draws the eye pattern of the inphase (I) or quadrature channel (Q) as the result display. The x axis is given in the unit "Symbols". The value range of the x axis is from -1 to +1 symbols and CANNOT be set.

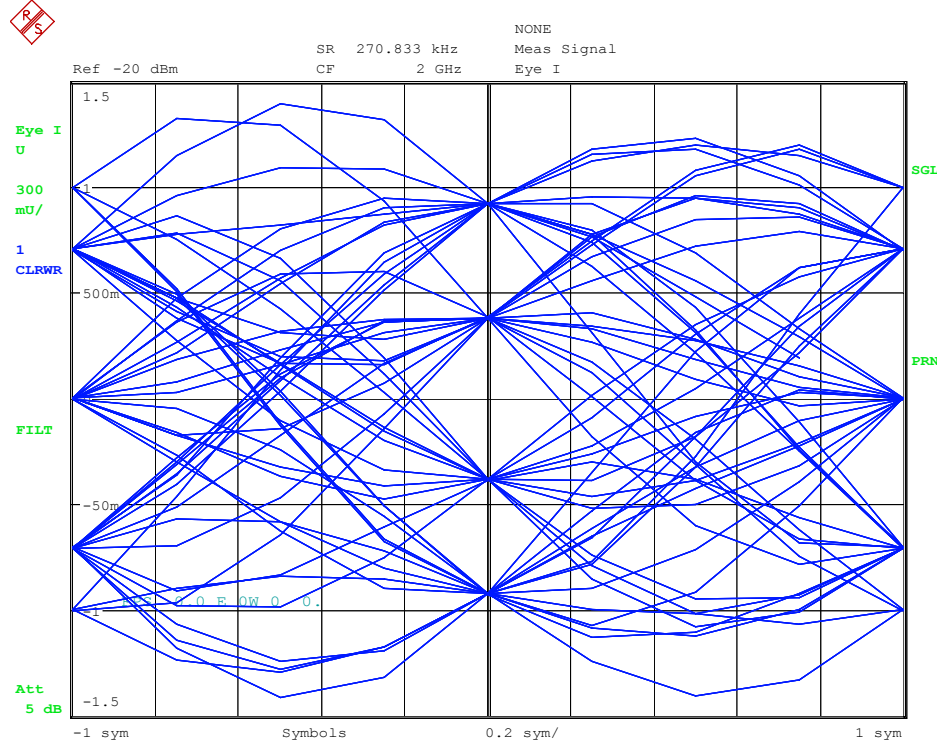

Date: 16.OCT.2002 13:15:53

Fig. 168 Result display EYE

IEC/IEEE bus commands :CALC:FEED 'XTIM:DDEM:MEAS'
 :CALC:FORM IEYE | QEYE

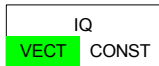

The *IQ VECT / CONST* softkey draws the complex measurement or reference signal as an X/Y plot.

VECT (= vector diagram)

All available samples are drawn and connected.

CONST (=constellation diagram)

Only the symbol decision instants are drawn and not connected.

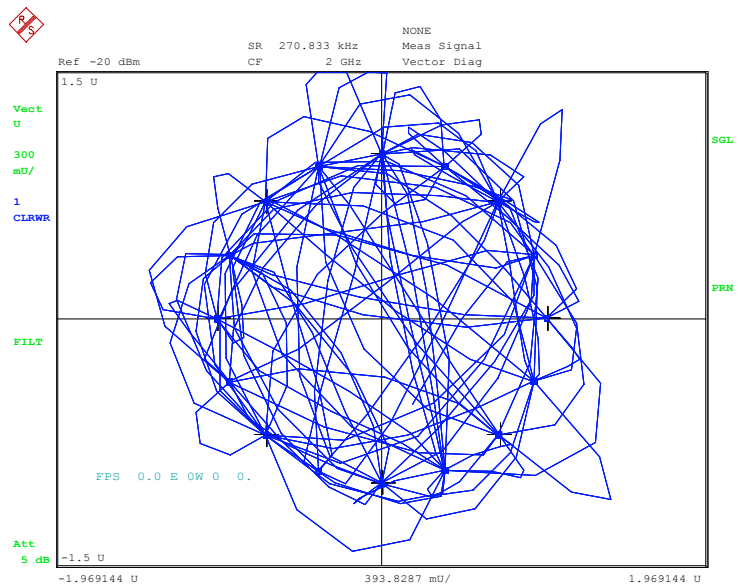

Date: 16.OCT.2002 13:15:17

Fig. 169 Result display *IQ VECT*

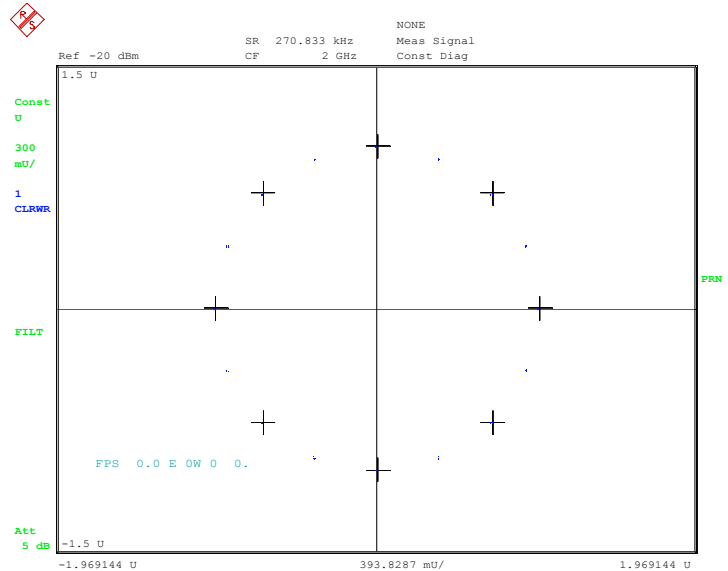

Date: 16.OCT.2002 13:14:03

Fig. 170 Result display *IQ CONST*

IEC/IEEE bus commands :CALC:FEED 'XTIM:DDEM:MEAS'
:CALC:FORM COMP | CONS

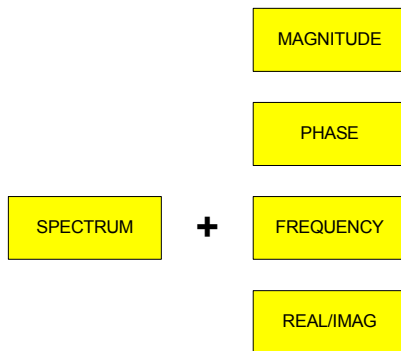

The *SPECTRUM* softkey switches the set result display to a spectral evaluation of the result parameter.

Spectral evaluation is possible for the following result parameters:
MAGNITUDE
PHASE
FREQUENCY (only for MSK and FSK modulation modes)
REAL/IMAG

The following diagrams provide examples of how the above parameters are displayed on screen. The y axis scaling including the unit (linear or logarithmic) is implemented by the y axis scaling of the corresponding measurement. The x axis scaling depends on the set symbol rate and the set *POINTS/SYMBOL*.

RANGE -> *LIN/LOG* switches the y axis scaling for the measurement display to logarithmic scaling:

- Spectrum → Magnitude
- Spectrum → Frequency (REL)
- Spectrum → Real/Imag

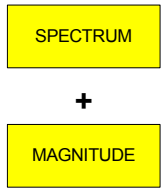

The *SPECTRUM / MAGNITUDE* softkey illustrates the spectral distribution of the *MAGNITUDE*.

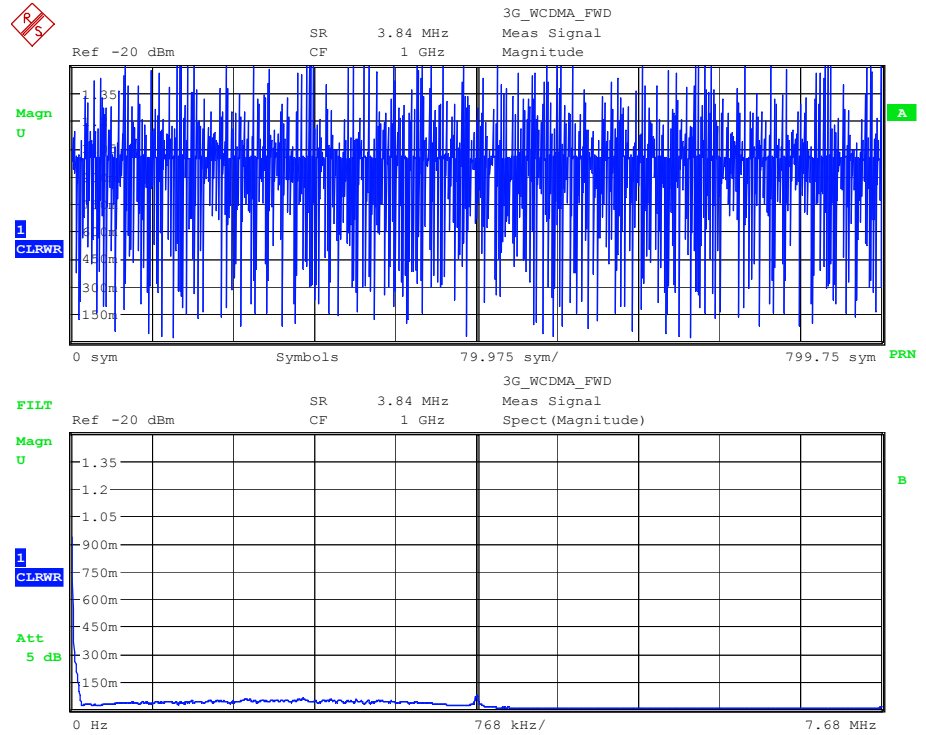

Date: 4.JUL.2003 09:12:36

Fig. 171 Result display *SPECTRUM MAGNITUDE*

```
IEC/IEEE bus commands :CALC:FEED 'XTIM:DDEM:MEAS'
                        :CALC:FORM MAGN
                        :DISP:WIND:TRAC:Y:SCAL:MODE REL
                        :CALC:DDEM:SPEC:STAT ON
```

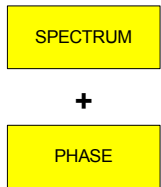

The *SPECTRUM / PHASE* softkey illustrates the spectral distribution of the *PHASE*.

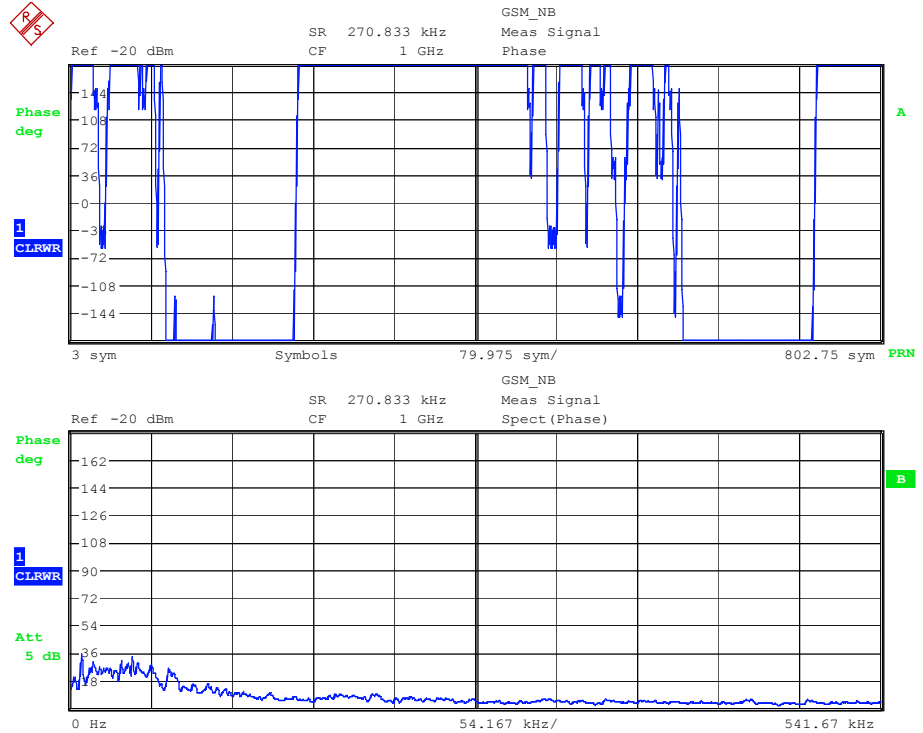

Date: 4.JUL.2003 09:14:58

Fig. 172 Result display SPECTRUM PHASE

```
IEC/IEEE bus commands :CALC:FEED 'XTIM:DDEM:MEAS'
                       :CALC:FORM UPH
                       :CALC:DDEM:SPEC:STAT ON
```

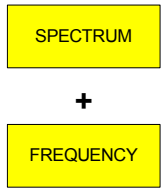

The *SPECTRUM / FREQUENCY* softkey illustrates the spectral distribution of the *FREQUENCY* trace.

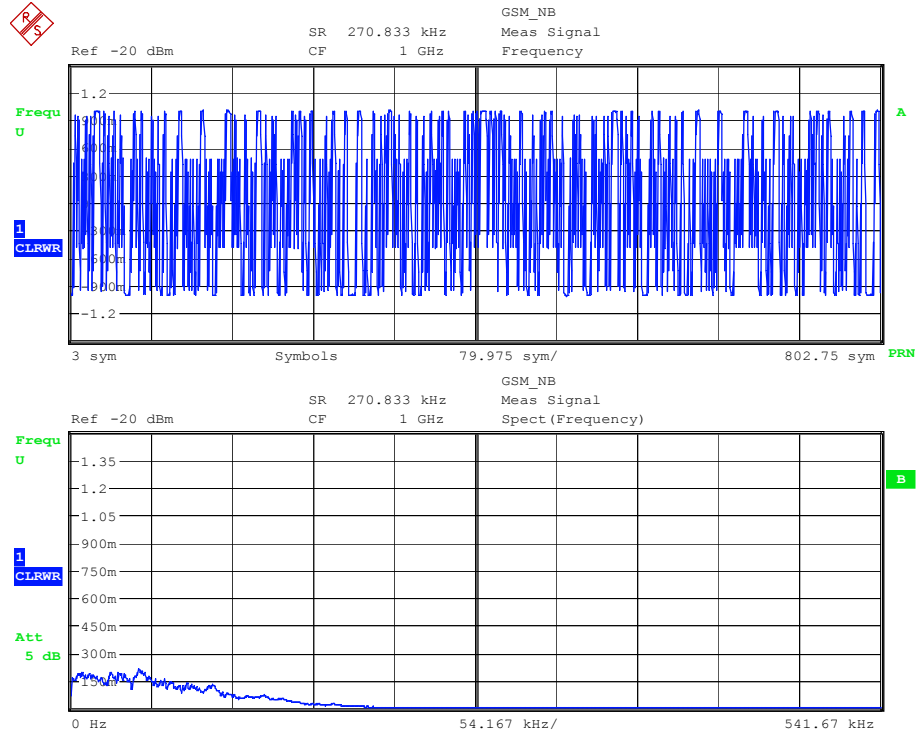

Date: 4.JUL.2003 09:15:39

Fig. 173 Result display *SIGNAL SPECTRUM FREQUENCY*

```
IEC/IEEE bus commands :CALC:FEED 'XTIM:DDEM:MEAS'
                        :CALC:FORM FREQ
                        :DISP:WIND:TRAC:Y:SCAL:MODE ABS
                        :CALC:DDEM:SPEC:STAT ON
```

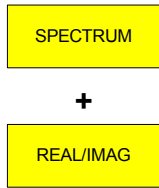

The *SPECTRUM / REAL/IMAG* softkey illustrates the spectral distribution of the *REAL/IMAG* trace.

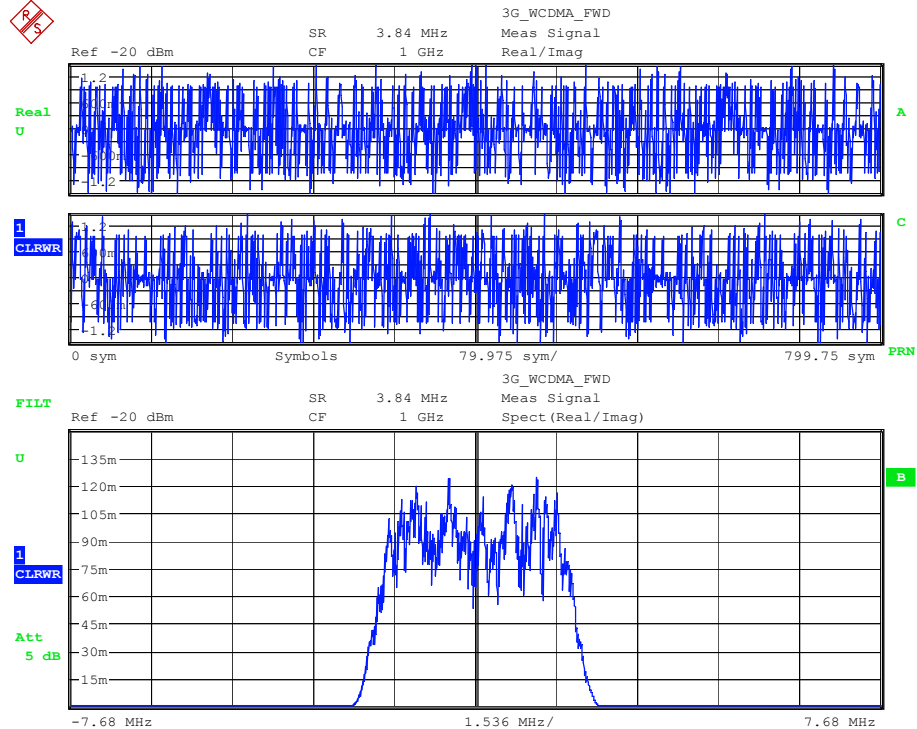

Date: 4.JUL.2003 09:13:20

Fig. 174 Result display *REAL/IMAG* (upper diagram)
Result display *SPECTRUM REAL/IMAG* (lower diagram)

```
IEC/IEEE bus commands :CALC:FEED 'XTIM:DDEM:MEAS'
                       :CALC:FORM RIM
                       :CALC:DDEM:SPEC:STAT ON
```

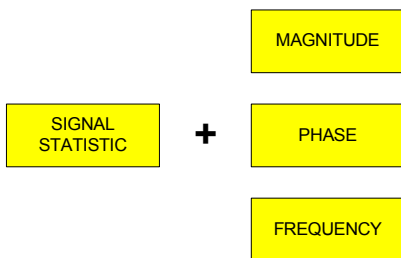

The *SIGNAL STATISTIC* softkey switches the set result display to a statistical evaluation of the result parameter. The display shows the frequency distribution (grouped in classes) of the measurement parameter as a bargraph. Classes outside the displayed range are assigned to the classes at the right or left margin of the representation.

Statistical evaluation is possible for the following result parameters:

- magnitude
- phase
- frequency (only for MSK and FSK modulation modes)

The following diagrams provide examples of how the above parameters are displayed on screen. The x axis scaling including the unit (linear or logarithmic) is implemented by the y axis scaling of the corresponding measurement.

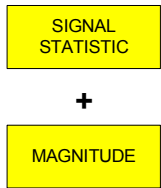

The *SIGNAL STATISTIC / MAGNITUDE* softkey illustrates the statistical distribution of the *MAGNITUDE*.

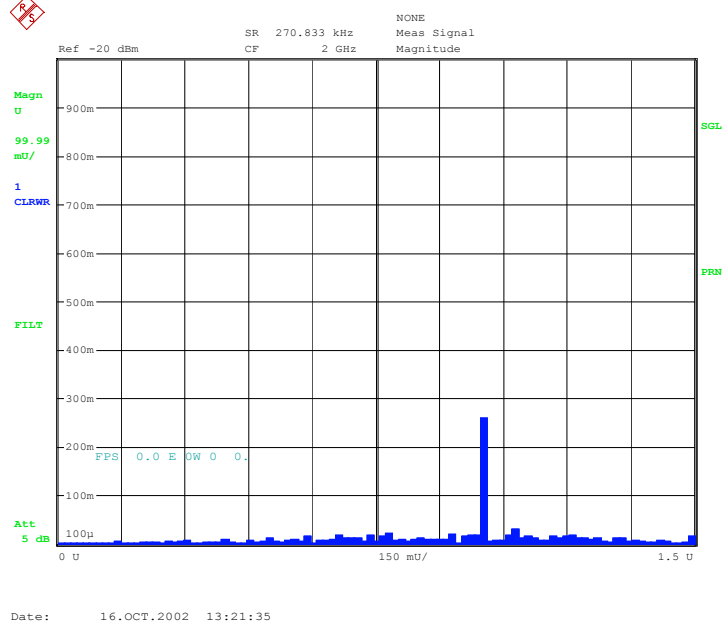

Fig. 175 Result display *SIGNAL STATISTIC MAGNITUDE*

The *RANGE -> Y_AXIS LIN / LOG* softkey is used to switch between linear and logarithmic scaling of the y axis. These setting options are possible for all statistical representations.

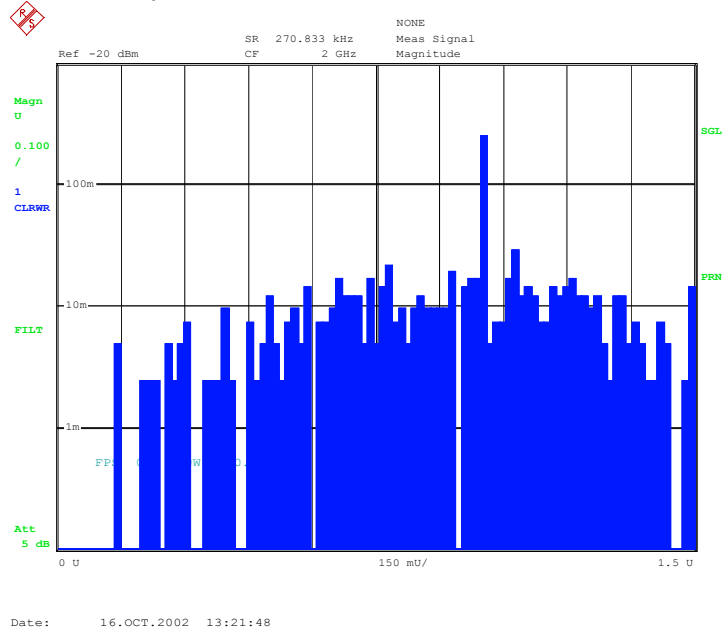

Fig. 176 Result display *SIGNAL STATISTIC MAGNITUDE (log)*

```
IEC/IEEE bus commands :CALC:FEED 'XTIM:DDEM:MEAS'
                       :CALC:FORM MAGN
                       :DISP:WIND:TRAC:Y:SCAL:MODE ABS
                       :CALC:STAT:CCDF:STAT ON
```

SIGNAL
STATISTIC

+

PHASE

The *SIGNAL STATISTIC / PHASE* softkey illustrates the statistical distribution of the *PHASE*.

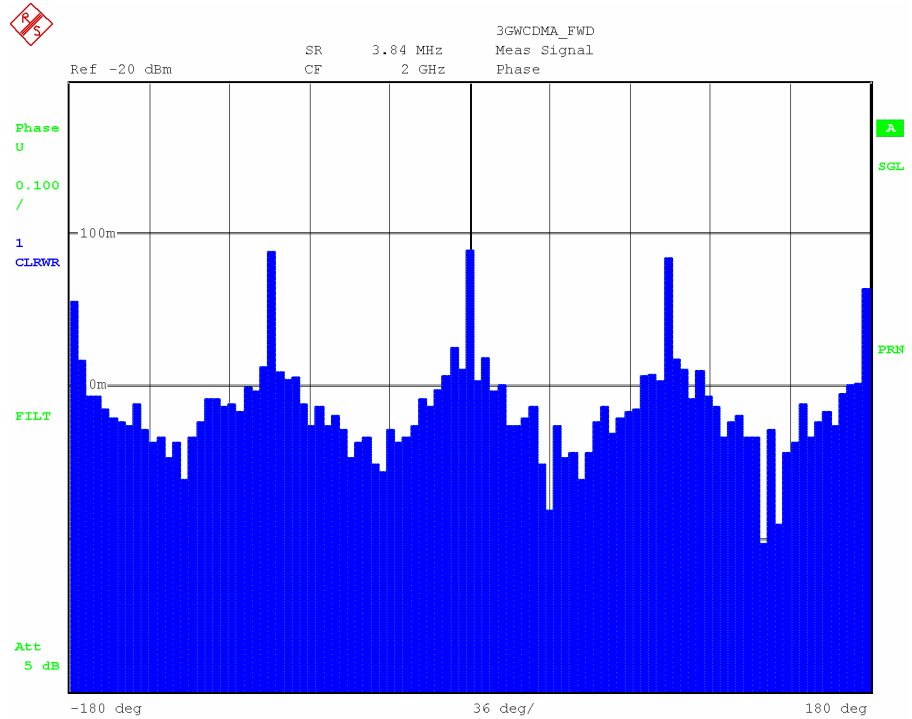

Date: 10.DEC.2002 09:22:44

Fig. 177 Result display SIGNAL STATISTIC PHASE

IEC/IEEE bus commands :CALC:FEED 'XTIM:DDEM:MEAS'
:CALC:FORM PHAS | UPH
:CALC:STAT:CCDF:STAT ON

SIGNAL
STATISTIC

+

FREQUENCY

The *SIGNAL STATISTIC / FREQUENCY* softkey illustrates the statistical distribution of the *FREQUENCY* trace.

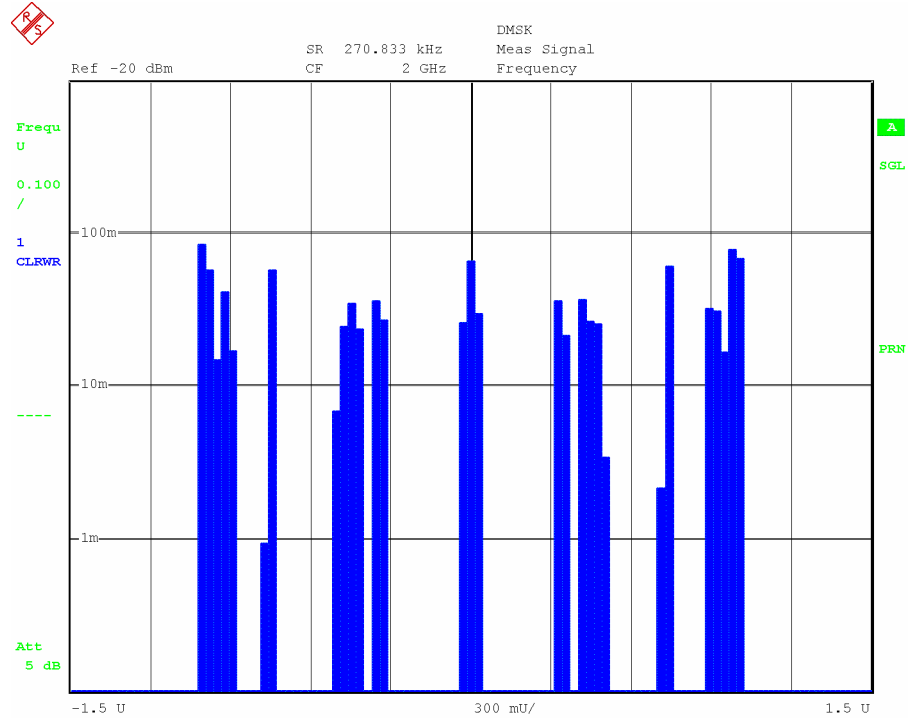

Date: 10.DEC.2002 09:24:35

Fig. 178 Result display *SIGNAL STATISTIC FREQUENC*

```
IEC/IEEE bus commands :CALC:FEED 'XTIM:DDEM:MEAS'
                       :CALC:FORM FREQ
                       :DISP:WIND:TRAC:Y:SCAL:MODE ABS|REL
                       :CALC:STAT:CCDF:STAT ON
```

Selection of Error Display - ERROR SIGNAL Softkey

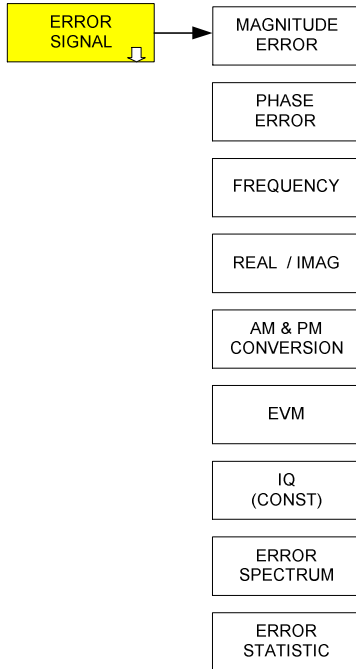

The *ERROR SIGNAL* softkey opens a submenu for setting the error display.

The following quantities can be displayed as a function of time:

- MAGNITUDE ERROR* Error vector magnitude
- PHASE ERROR* Phase error
- FREQ ERROR* Frequency error (only MSK and FSK)
- REAL/IMAG* Inphase and quadrature component

Display in the I/Q plane

- IQ-ERROR* I/Q error display

Display of derived quantities:

- AM&PM CONVERSION* Nonlinear distortion
- ERROR SPECTRUM* Spectral evaluation
- ERROR STATISTIC* Statistical evaluations

IEC/IEEE bus command : `CALC:FEED 'XTIM:DDEM:ERR:MPH'`

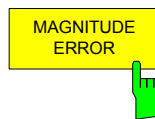

The *MAGNITUDE ERROR* softkey activates the display of the magnitude difference between the *MEASUREMENT VECTOR* and the *REFERENCE VECTOR* as a function of time.

$$MAG_ERR(t) = |MEAS(t)| - |REF(t)|;$$

The scaling of the measurement results is relative to the selected constellation diagram (unit circle).

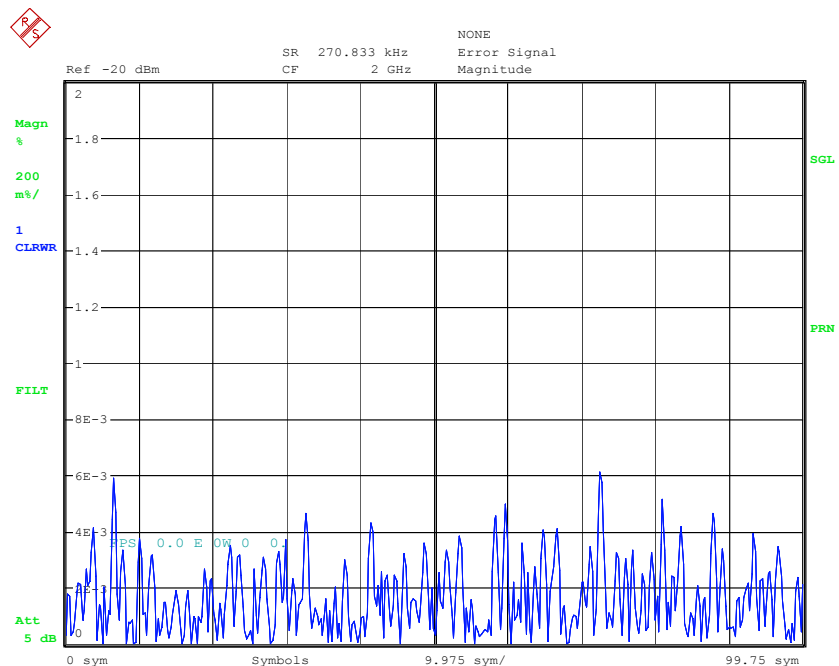
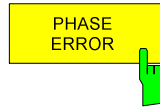

Fig. 179 *MAGNITUDE ERROR* result display

IEC/IEEE bus commands :CALC:FEED 'XTIM:DDEM:ERR:MPH'
:CALC:FORM MAGN



The *PHASE ERROR* softkey activates the display of the phase difference between the *MEASUREMENT VECTOR* and the *REFERENCE VECTOR* as a function of time.

$$PHASE_ERR(t) = \arg(MEAS(t) \cdot REF^*(t));$$

with MEAS the complex vector of the measurement signal,
and REF the complex vector of the reference signal.

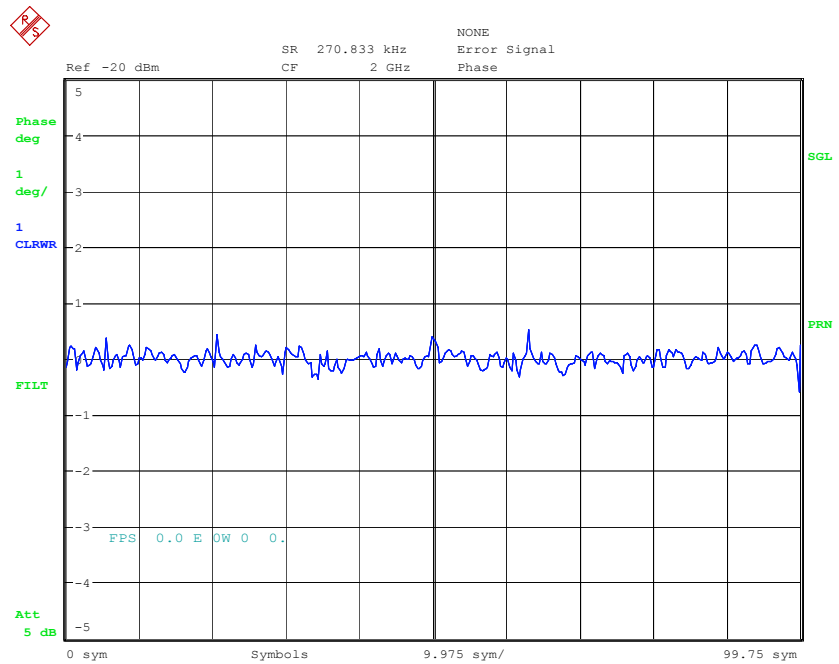

Date: 16.OCT.2002 13:27:14

Fig. 180 PHASE ERROR result display

IEC/IEEE bus commands :CALC:FEED 'XTIM:DDEM:ERR:MPH'
:CALC:FORM PHAS

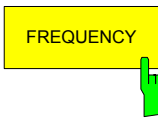

The *FREQUENCY* softkey displays the current frequency error as a function of time for the sample points. The frequency error is calculated from the difference in current frequencies.

$$FREQ_ERR(t) = FREQ(MEAS(t)) - FREQ(REF(t));$$

ABSOLUTE Absolute frequency scaling

RELATIVE Relative frequency scaling, i.e. referenced to the set reference deviation

This display is only available with MSK and FSK modulation methods.

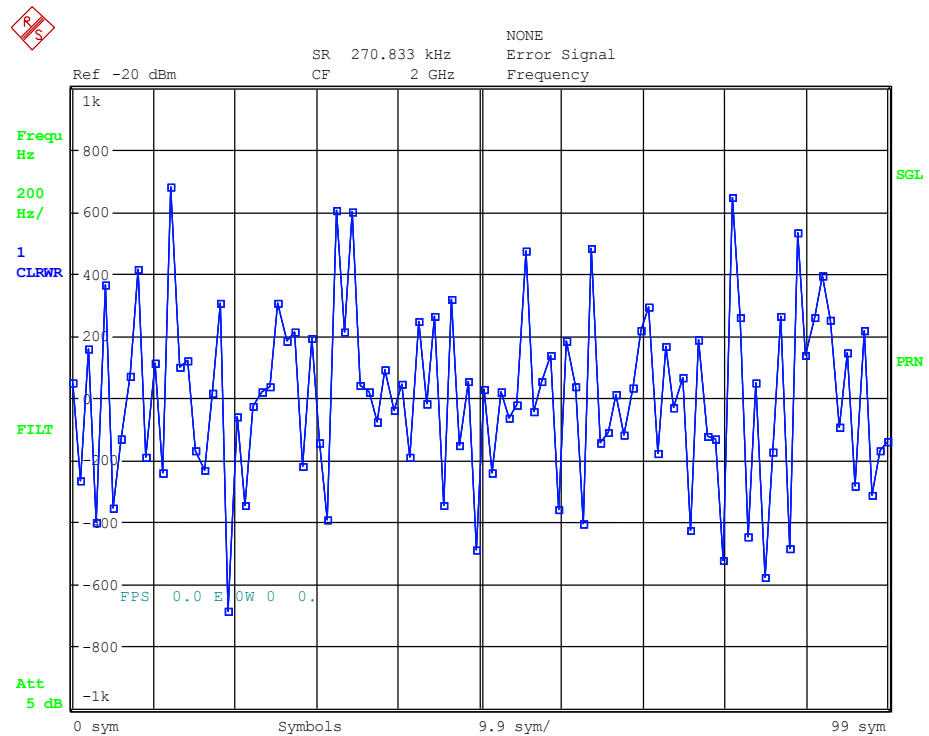

Date: 16.OCT.2002 13:30:24

Fig. 181 *FREQ ERROR* result display

IEC/IEEE bus commands :CALC:FEED 'XTIM:DDEM:ERR:MPH'
 :CALC:FORM FREQ
 :DISP:WIND:TRAC:Y:SCAL:MODE ABS|REL

REAL/IMAG

The *REAL / IMAG* softkey uses a split screen to display the inphase and quadrature components of the error signal as a function of time.

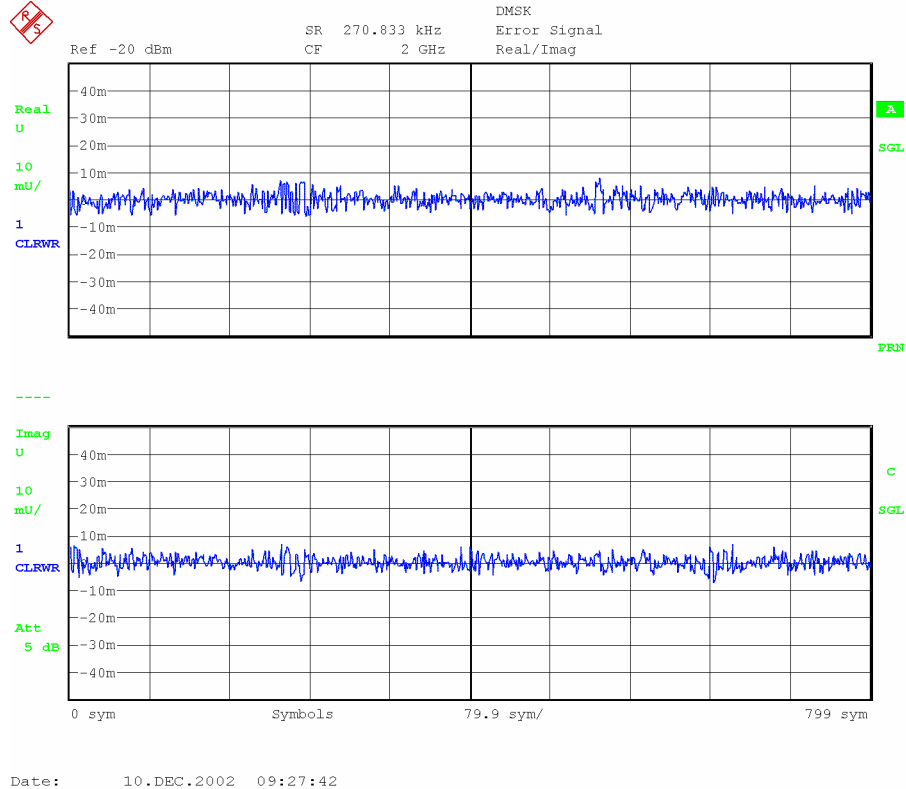

Fig. 182 REAL / IMAG result display

IEC/IEEE bus commands :CALC:FEED 'XTIM:DDEM:ERR:MPH'
:CALC:FORM RIM

AM & PM CONVERSION

The *AM & PM CONVERSION* softkey displays the amplitude or phase error of the measurement signal relative to the reference signal level (i.e. of an ideal, undistorted transmission signal). The test points are used to calculate the distortion characteristic, on which the markers move.

The result window is divided into two parts:

The *AM/AM* display shows the logarithm level of the reference signal horizontally, and the logarithm level of the measurement signal vertically. Nonlinear level distortion causes trace deviations from the 0 dB line.

The *AM/PM* display shows the logarithm level of the reference signal horizontally, and the linear phase error vertically. Phase distortion also causes trace deviations from the 0° line.

This measurement is only available with PSK and QAM modulation.

Note: If a MEAS filter in the demodulation path has been switched on, the setting MEAS RESULT -> RESULT = RAW must be selected, otherwise the characteristic will be falsified by the MEAS filtering.

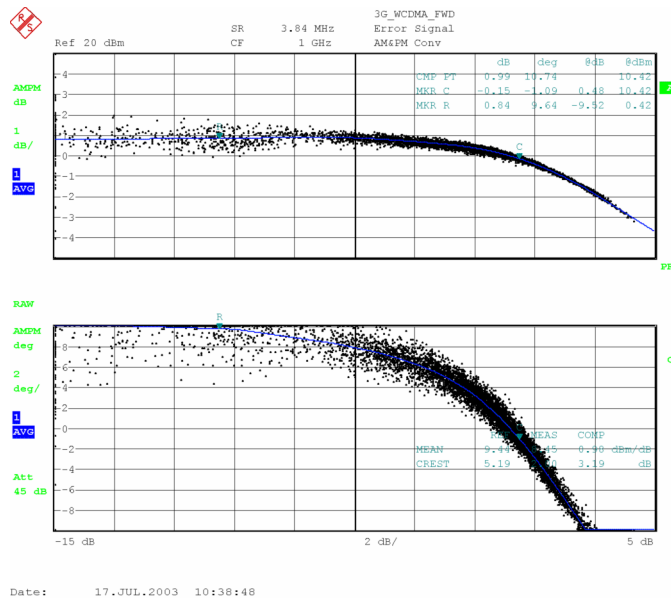

Fig. 183 AM & PM CONVERSION result display (AM-AM upper diagram, AM-PM lower diagram)

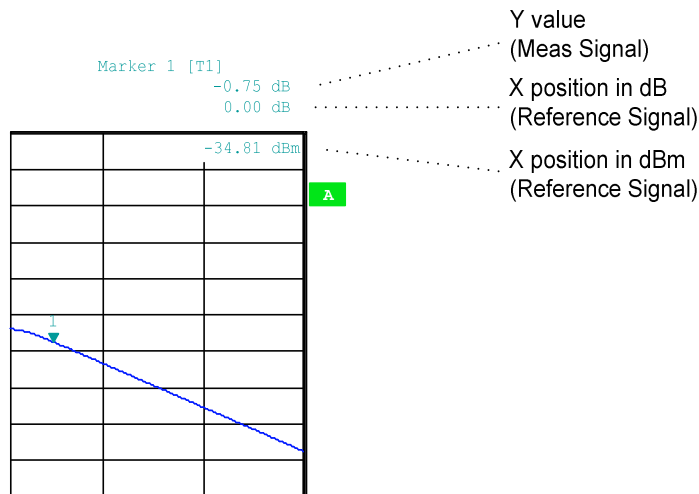
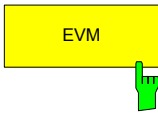

Fig. 184 AM & PM CONVERSION result display, marker field)

The MKR FCT -> COMP PT marker functions are used to calculate the compression point from the trace and the input power (Fig. 183, upper diagram). The difference between the mean powers or crest factors of the measurement and reference signals is used to calculate the results for the power compression and reduction of the current modulation of the DUT. The results (power compression and reduction of the crest factor) are shown in the lower diagram. These values are determined by using two markers which are automatically positioned on the interpolated distortion characteristic. If one of the two markers leaves the display area, these numeric values will not be displayed

IEC/IEEE bus commands : CALC:FEED 'XTIM:DDEM:ERR:MPH'
 : CALC:FORM CONV
 : CALC:MARK1:X:CONV:ABS?



The *EVM* (error vector magnitude) softkey displays the error vector magnitude as a function of time.

The calculation formula depends on the selected standard; the error vector magnitude typically refers to the unit circle. The calculation formulae are explained in chapter 9 "*Glossary and Formulae*".

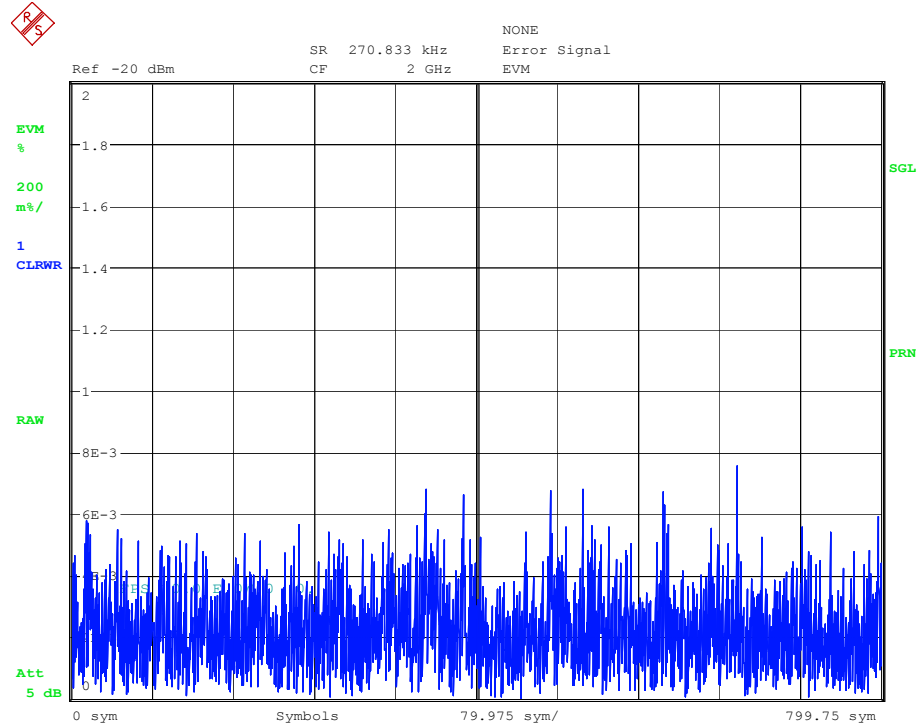

Date: 16.OCT.2002 13:34:12

Fig. 185 EVM (error vector magnitude) result display

```
IEC/IEEE bus commands : CALC:FEED 'XTIM:DDEM:ERR:VECT'
                        : CALC:FORM MAGN
```

IQ ERROR (VECTOR)

The *IQ ERROR* softkey displays the complex error vector in the I/Q plane. It opens a window for selecting the type of display.

IQ ERROR (CONST)

VECTOR The trace is depicted with all available samples, and the samples are connected.

CONSTELLATION Only the symbol decision points are depicted; they are not connected.

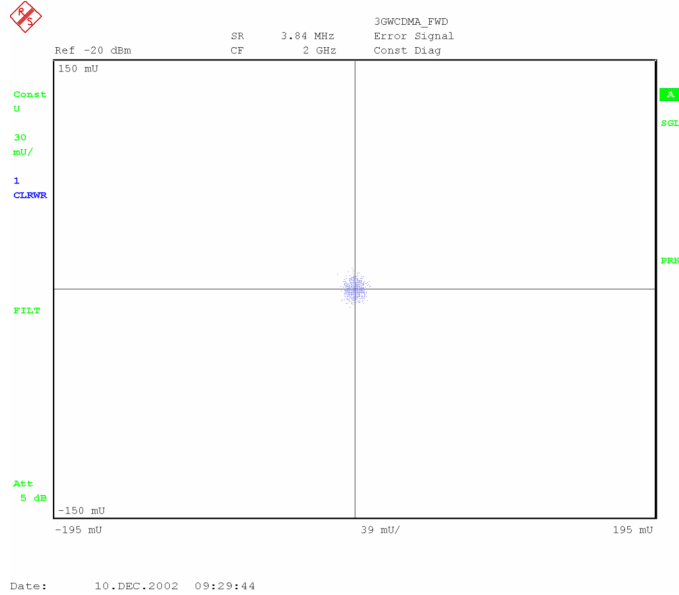

Fig. 186 *IQ ERROR* result display (constellation diagram)

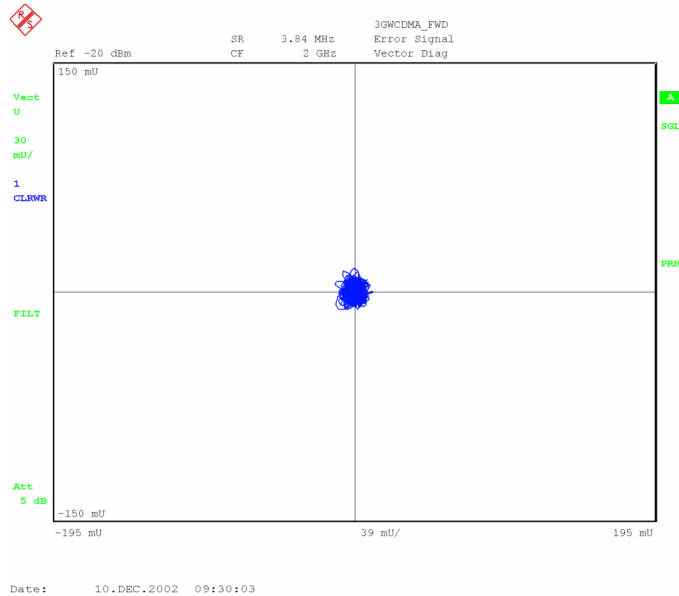
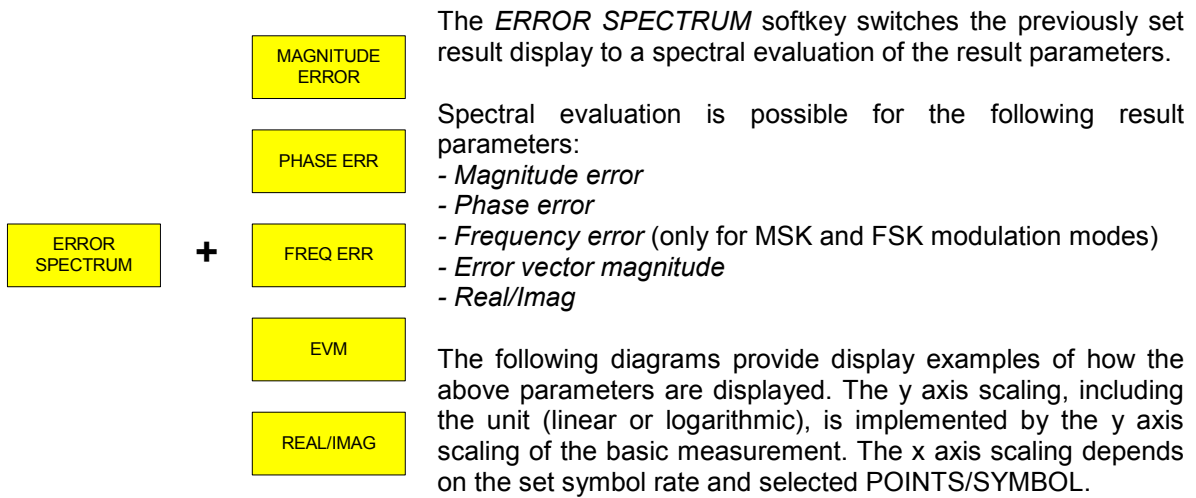

Fig. 187 *IQ ERROR* result display (vector display)

IEC/IEEE bus commands :CALC:FEED 'XTIM:DDEM:ERR:VECT'
:CALC:FORM COMP | CONS



The *ERROR SPECTRUM* softkey switches the previously set result display to a spectral evaluation of the result parameters.

Spectral evaluation is possible for the following result parameters:

- *Magnitude error*
- *Phase error*
- *Frequency error* (only for MSK and FSK modulation modes)
- *Error vector magnitude*
- *Real/Imag*

The following diagrams provide display examples of how the above parameters are displayed. The y axis scaling, including the unit (linear or logarithmic), is implemented by the y axis scaling of the basic measurement. The x axis scaling depends on the set symbol rate and selected POINTS/SYMBOL.

RANGE -> *LIN/LOG* switches the y axis scaling for the measurement display to logarithmic scaling:

- Spectrum → Magnitude Error
- Spectrum → Frequency Error (REL)
- Spectrum → Error Real/Imag
- Spectrum → EVM

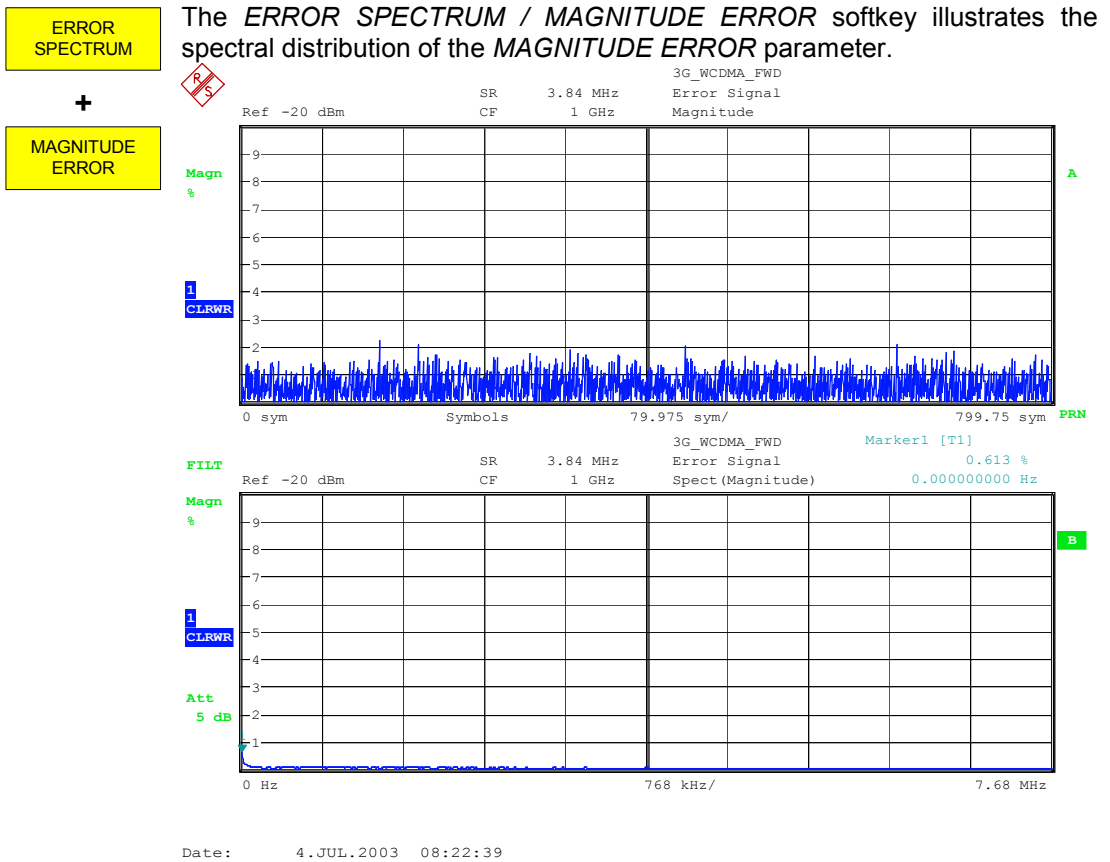

Fig. 188 Result display *MAGNITUDE ERROR* (upper diagram)
 Result display *ERROR SPECTRUM* -> *MAGNITUDE ERROR* (lower diagram)

```

IEC/IEEE bus commands :CALC:FEED 'XTIM:DDEM:ERR:MPH'
                       :CALC:FORM MAGN
                       :CALC:DDEM:SPEC:STAT ON | OFF
    
```

ERROR SPECTRUM

The *ERROR SPECTRUM / PHASE ERROR* softkey illustrates the spectral distribution of the *PHASE ERROR* parameter.

+

PHASE ERR

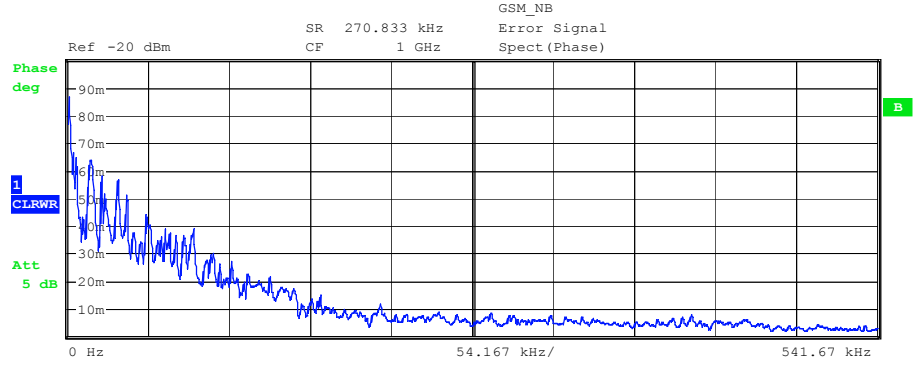
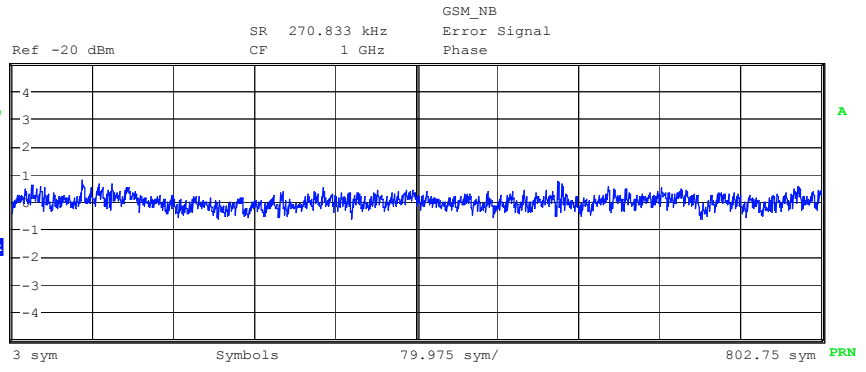

Date: 4.JUL.2003 08:27:47

Fig. 189 Result display PHASE ERROR (upper diagram)
Result display ERROR SPECTRUM -> PHASE ERRO (lower diagram)

IEC/IEEE bus commands :CALC:FEED 'XTIM:DDEM:ERR:MPH'
:CALC:FORM PHAS
:CALC:DDEM:SPEC:STAT ON | OFF

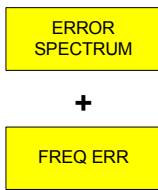

The *ERROR SPECTRUM / FREQ ERROR* softkey illustrates the spectral distribution of the *FREQUENCY ERROR* parameter.

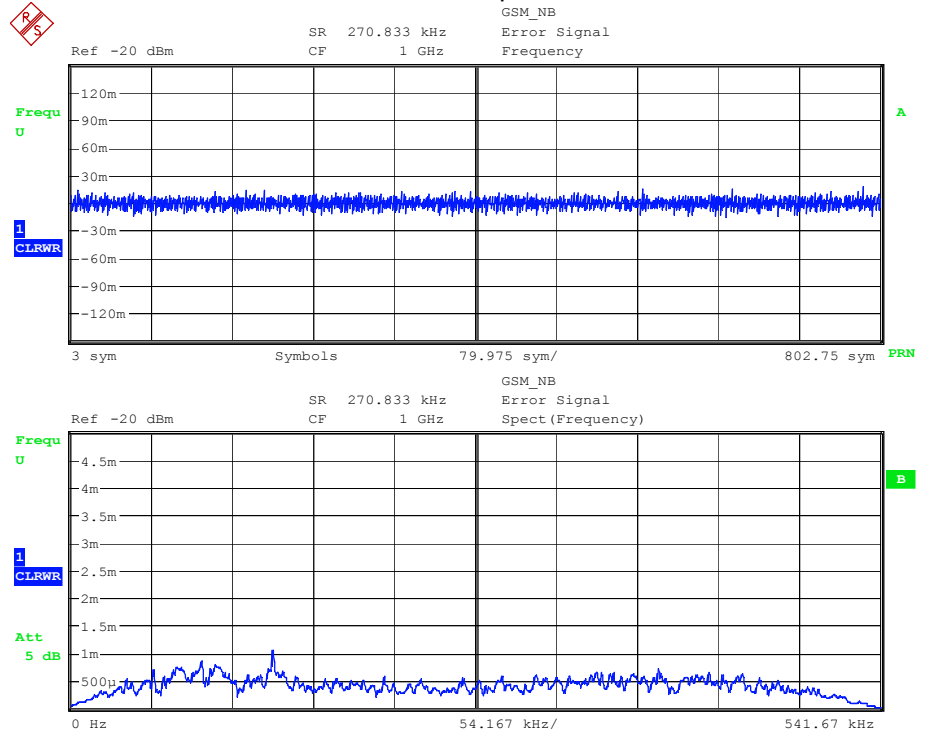

Date: 4.JUL.2003 08:28:51

Fig. 190 Result display *FREQUENCY ERROR* (upper diagram)
Result display *ERROR SPECTRUM FREQUENCY ERROR* (lower diagram)

```
IEC/IEEE bus commands :CALC:FEED 'XTIM:DDEM:ERR:MPH'
                       :CALC:FORM FREQ
                       :CALC:DDEM:SPEC:STAT ON | OFF
```

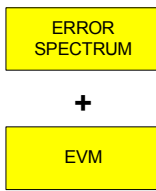

The *ERROR SPECTRUM / EVM* softkey illustrates the spectral distribution of the *EVM* parameter.

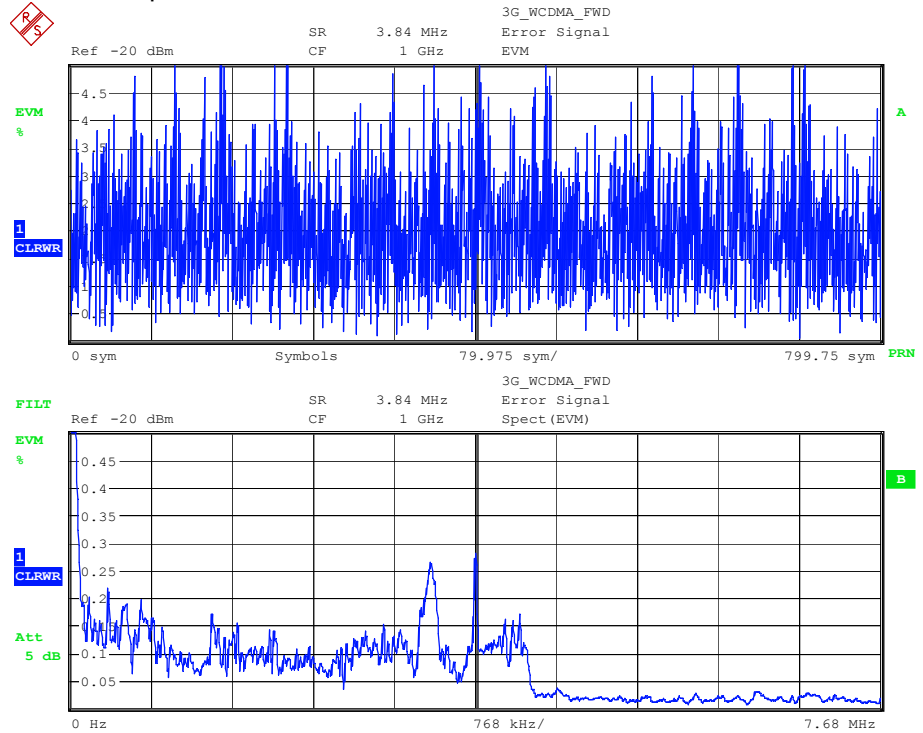

Date: 4.JUL.2003 08:25:23

Fig. 191 Result display *EVM* (upper diagram)
Result display *ERROR SPECTRUM* -> *EVM* (lower diagram)

```
IEC/IEEE bus commands :CALC:FEED 'XTIM:DDEM:ERR:VECT'  
:CALC:FORM MAGN  
:CALC:DDEM:SPEC:STAT ON | OFF
```

ERROR SPECTRUM + **REAL/IMAG**

The **ERROR SPECTRUM / REAL/IMAG** softkey illustrates the spectral distribution of the complex error signal.

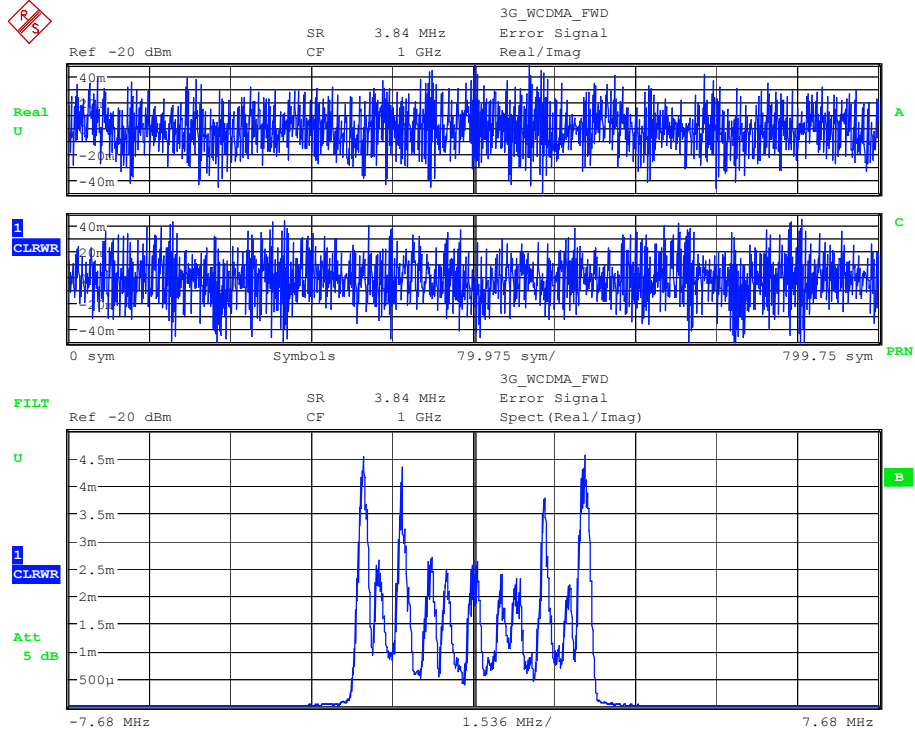

Date: 4.JUL.2003 08:24:13

Fig. 192 Result display **REAL/IMAG** (upper diagram)
Result display **ERROR SPECTRUM REAL/IMAG** (lower diagram)

```
IEC/IEEE bus commands :CALC:FEED 'XTIM:DDEM:ERR:VECT'  
:CALC:FORM MAGN  
:CALC:DDEM:SPEC:STAT ON | OFF
```

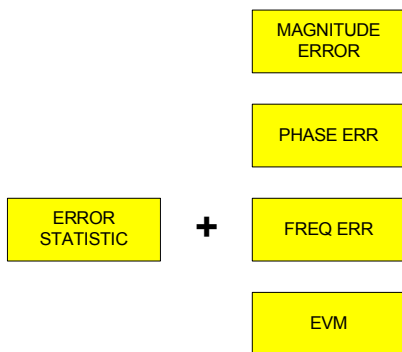

The **ERROR STATISTIC** softkey switches the previously set result display to a statistical evaluation of the result parameters.

Statistical evaluation is possible for the following result parameters:

- Magnitude error
- Phase error
- Frequency error (only for MSK and FSK modulation modes)
- Error vector magnitude

Statistical displays are particularly conclusive if nothing but the symbol decision instants are used (PTS / SYMB setting = 1).

The following diagrams provide display examples of how the above parameters are displayed. The x axis scaling, including the unit (linear or logarithmic), is implemented by the y axis scaling of the basic measurement.

ERROR STATISTIC The *ERROR STATISTIC / MAGNITUDE ERROR* softkey displays the statistical distribution of the *MAGNITUDE ERROR* parameter.

+

MAGNITUDE ERROR

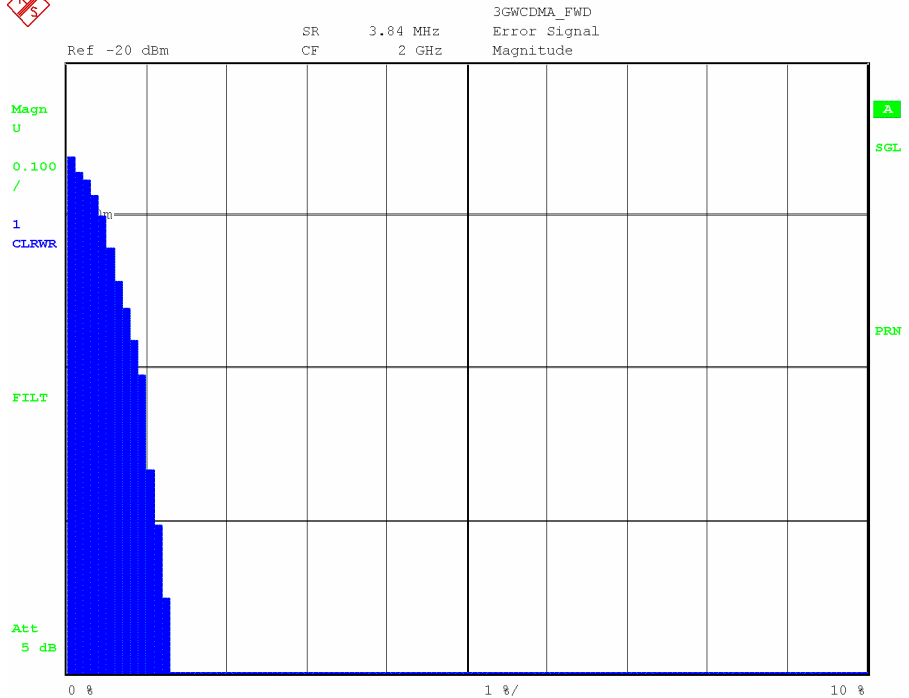

Date: 10.DEC.2002 09:30:47

Fig. 193 *ERROR STATISTIC MAGNITUDE* result display

IEC/IEEE bus commands :CALC:FEED 'XTIM:DDEM:ERR:MPH'
 :CALC:FORM MAGN
 :CALC:STAT:CCDF:STAT ON | OFF

ERROR STATISTIC The *ERROR STATISTIC / PHASE ERROR* softkey displays the statistical distribution of the *PHASE ERROR* parameter.

+

PHASE ERR



3GWCDDMA_FWD
 Error Signal
 SR 3.84 MHz
 CF 2 GHz
 Ref -20 dBm
 Phase

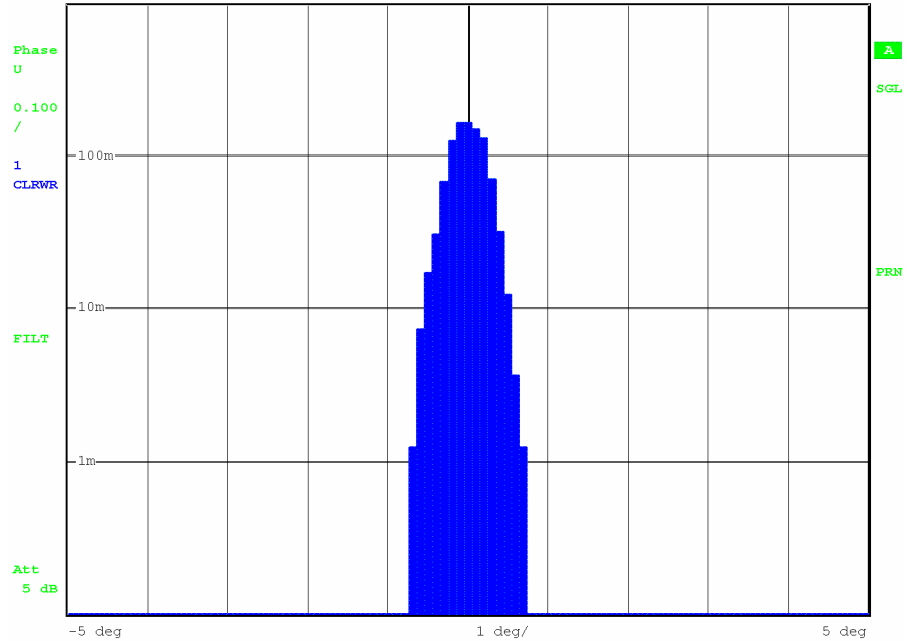

Date: 10.DEC.2002 09:32:08

Fig. 194 ERROR STATISTIC PHASE result display

IEC/IEEE bus commands :CALC:FEED 'XTIM:DDEM:ERR:MPH'
 :CALC:FORM PHAS
 :CALC:STAT:CCDF:STAT ON | OFF

ERROR STATISTIC The *ERROR STATISTIC / FREQ ERROR* softkey displays the statistical distribution of the *FREQUENCY ERROR* parameter.

+

FREQ ERR

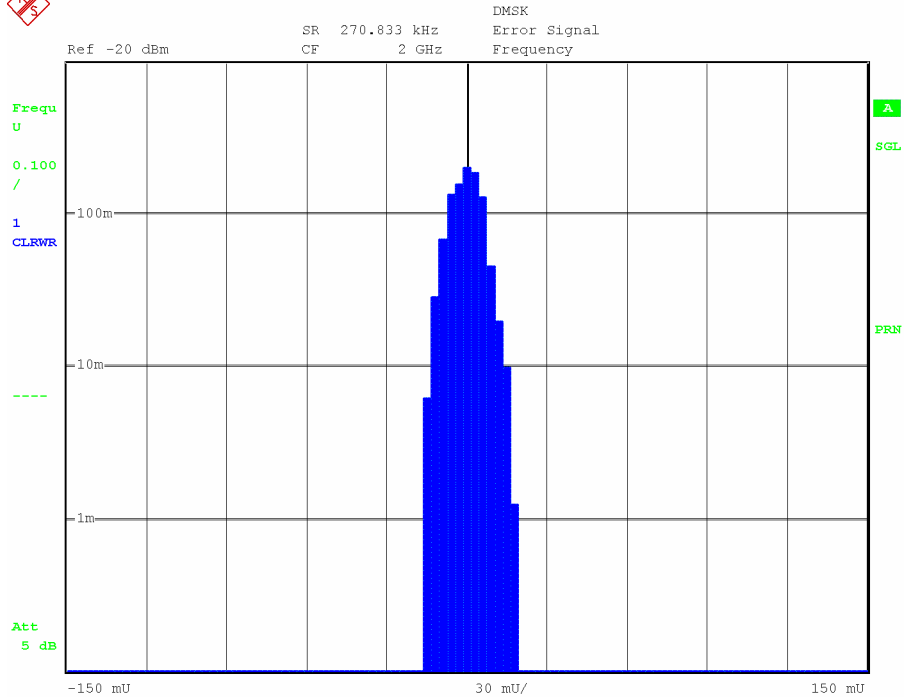

Date: 10.DEC.2002 09:34:39

Fig. 195 *ERROR STATISTIC FREQUENCY* result display

IEC/IEEE bus commands :CALC:FEED 'XTIM:DDEM:ERR:MPH'
 :CALC:FORM FREQ
 :CALC:STAT:CCDF:STAT ON | OFF

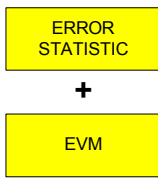

The *ERROR STATISTIC / EVM* softkey displays the statistical distribution of the EVM parameter.

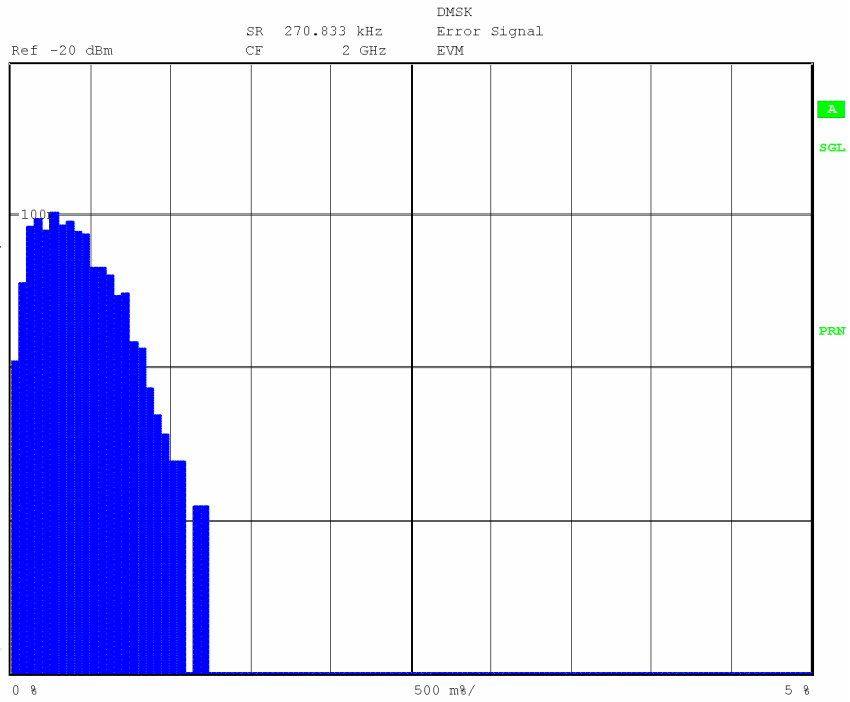

Date: 10.DEC.2002 09:35:33

Fig. 196 *ERROR STATISTIC EVM* result display

```
IEC/IEEE bus commands : CALC:FEED 'XTIM:DDEM:ERR:VECT'
                        : CALC:FORM MAGN
                        : CALC:STAT:CCDF:STAT ON | OFF
```

Selection of the Raw Signal - CAPTURE BUFFER Softkey

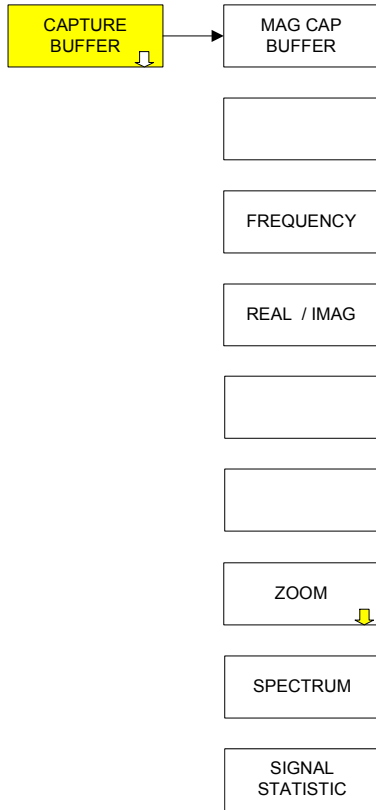

The *CAPTURE BUFFER* softkey opens a submenu for setting the display of the raw signal of the record buffer.

The following quantities can be displayed as a function of time:

MAG CAP BUFFER Record buffer magnitude

FREQUENCY Frequency (only MSK and FSK)

REAL/IMAG Inphase and quadrature component

Display of derived quantities:

SPECTRUM Spectral evaluation

SIGNAL STATISTIC Statistical evaluations

ZOOM opens a submenu with for selecting the displayed section of the capture buffer and for controlling the demodulation

The *EVALUATION LINES* for limiting the evaluation area do not have any relevance in the Capture Buffer evaluations.

IEC/IEEE bus command :CALC:FEED 'TCAP'

MAG CAP
BUFFER

The *MAG CAP BUFFER* shows the magnitude of the unprocessed signal of the *RECORD BUFFER*.

The complete length of the *RECORD BUFFER* is shown, while all other display modes display only the *RESULT RANGE*. The displayed image is shown with absolute level scaling only.

This display mode is useful for doing the following:

Configuring a measurement, especially trigger offset settings

Selecting individual bursts

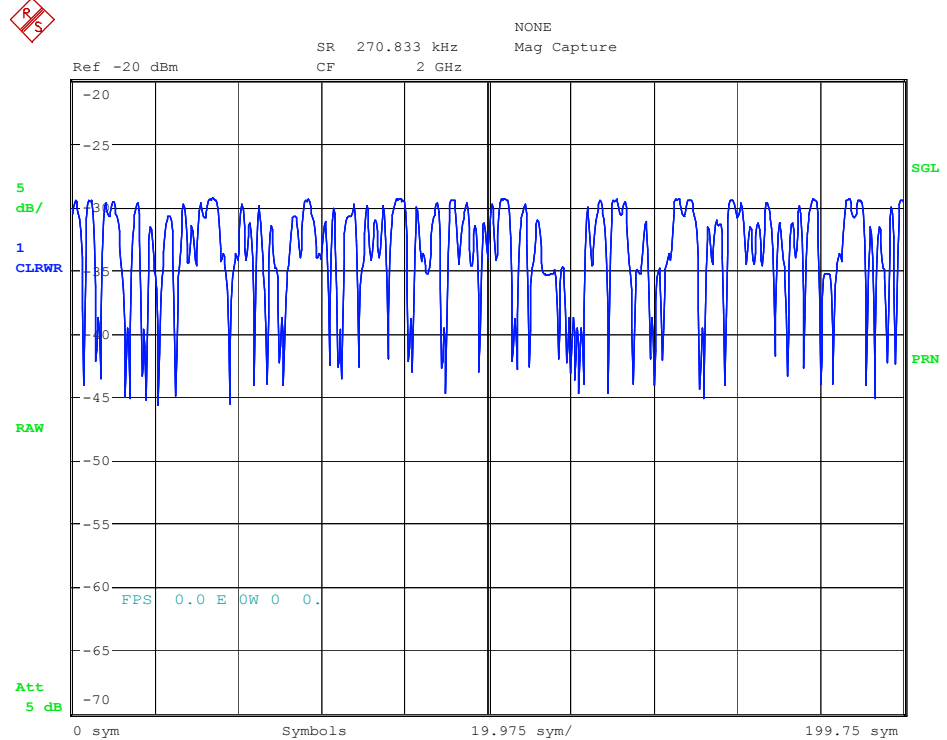

Date: 16.OCT.2002 12:59:32

Fig. 197 Result display *MAGNITUDE CAPTURE BUFFER*

IEC/IEEE bus commands :CALC:FEED 'TCAP'
:CALC:FORM MAGN

FREQUENCY

The *FREQUENCY* softkey displays the frequency modulated signal of the unprocessed *RECORD BUFFERS*. The complete length of the *RECORD BUFFER* is shown. The softkey is only available for modulation types MSK and FSK.

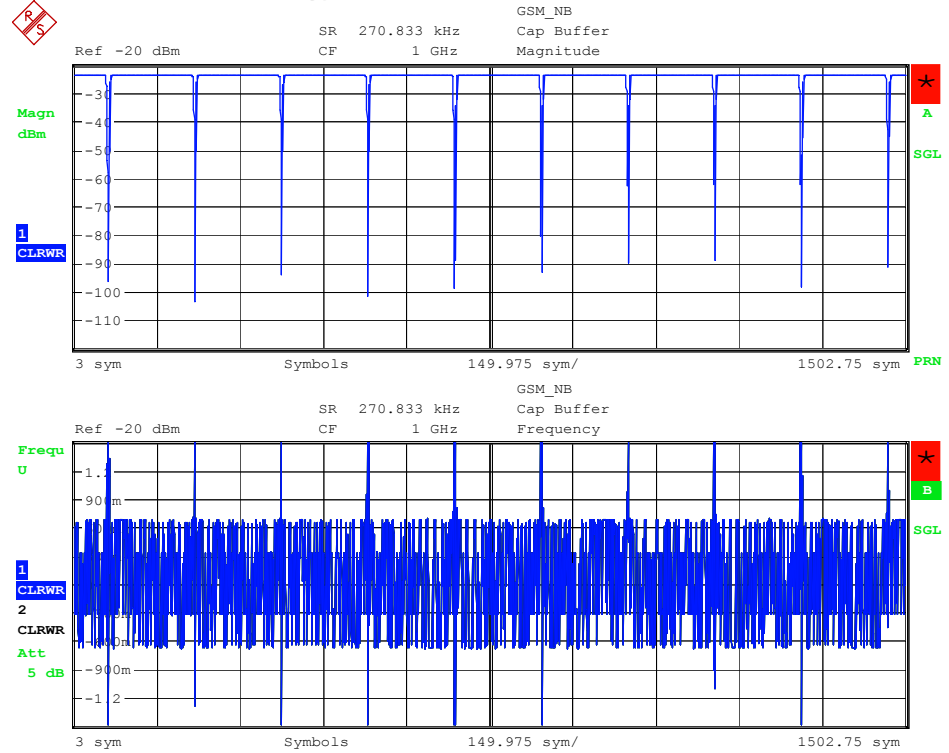

Date: 2.JUL.2003 14:30:17

Fig. 198 Result display *MAGNITUDE CAPTURE BUFFER* (upper diagram)
Result display *CAPTURE BUFFER -> FREQUENCY* (lower diagram)

IEC/IEEE bus commands :CALC:FEED 'TCAP'
:CALC:FORM FREQ
:DISP:WIND:TRAC:Y:SCAL:MODE ABS | REL

REAL/IMAG

The *REAL/IMAG* softkey displays the real and imaginary component of the unprocessed signal of the *RECORD BUFFER*. The display is standardized to the *REFERENCE LEVEL* and covers the complete length of the *RECORD BUFFER*.

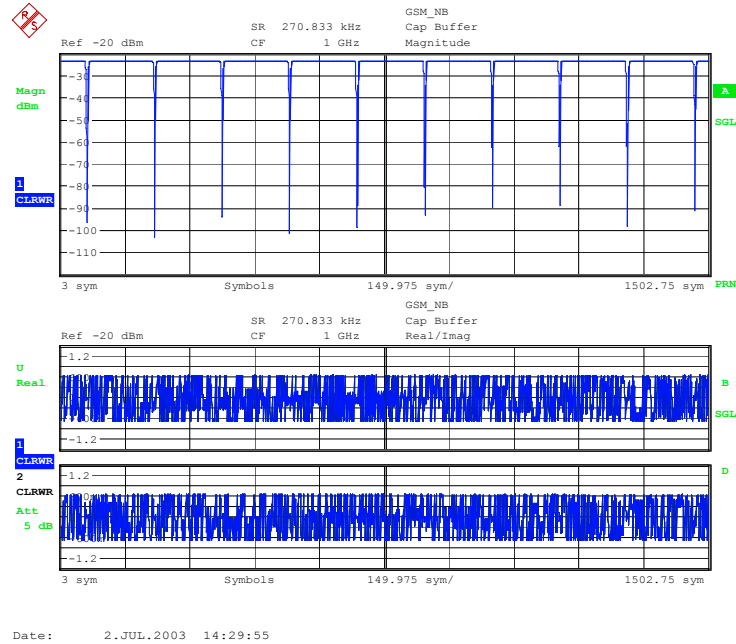
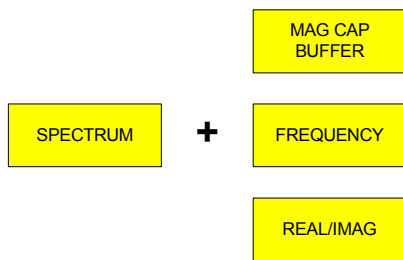

Fig. 199 Result display *MAGNITUDE CAPTURE BUFFER* (upper diagram)
Result display *CAPTURE BUFFER -> REAL/IMAG* (lower diagram)

IEC/IEEE bus commands :CALC:FEED 'TCAP'
:CALC:FORM RIM



The *SPECTRUM* softkey switches the set result display to a spectral evaluation (FFT) of the result parameter.

Spectral evaluation is possible for the following result parameters:

- MAGNITUDE CAPTURE BUFFER*
- FREQUENCY CAPTURE BUFFER* (only for MSK and FSK modulation modes)
- REAL/IMAG CAPTURE BUFFER*

The following diagrams provide examples of how the above parameters are displayed on screen. The y axis scaling including the unit (linear or logarithmic) is implemented by the y axis scaling of the corresponding measurement. The x axis scaling depends on the set symbol rate and the set *POINTS/SYMBOL*.

RANGE -> LIN/LOG switches the y axis scaling for the measurement display to logarithmic scaling:

- Spectrum → Capture Buffer Frequency (REL)
- Spectrum → Capture Buffer Real/Imag

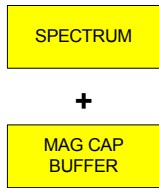

Simultaneously selecting the *SPECTRUM* and *MAG CAP BUFFER* softkeys shows the FFT magnitude versus the magnitude for the unprocessed signal in the *RECORD BUFFER*.

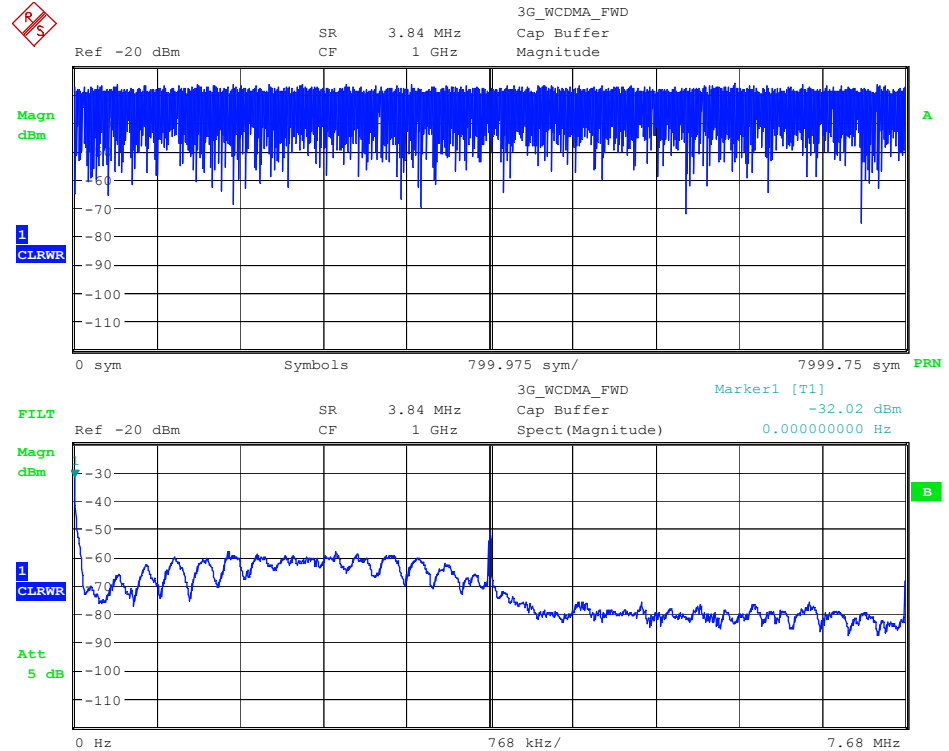

Date: 3.JUL.2003 08:52:07

Fig. 200 Result display *CAPTURE BUFFER MAGNITUDE* (upper diagram)
Result display *SPECTRUM -> CAPTURE BUFFER MAGNITUDE* (lower diagram)

IEC/IEEE bus commands :CALC:FEED 'TCAP'
:CALC:FORM MAGN
:CALC:DDEM:SPEC:STAT ON

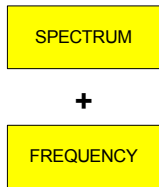

Simultaneously selecting the *SPECTRUM* and *FREQUENCY* softkeys shows the FFT magnitude versus the frequency modulated signal in the *RECORD BUFFER*.

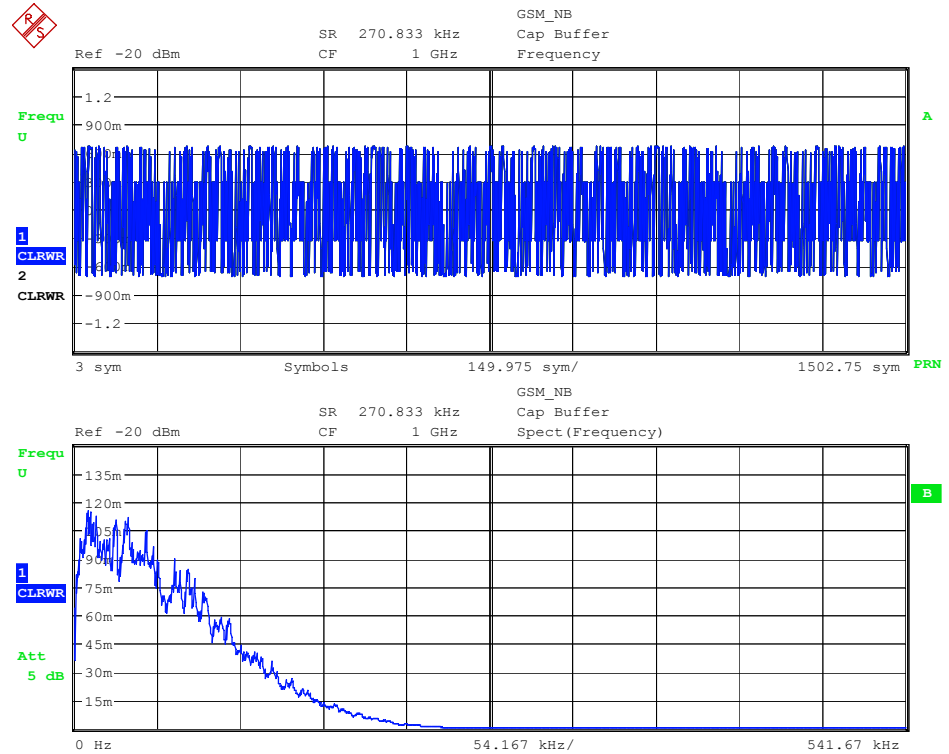

Date: 4.JUL.2003 07:45:32

Fig. 201 Result display *CAPTURE BUFFER FREQUENCY* (upper diagram)
Result display *SPECTRUM -> CAPTURE BUFFER FREQUENCY* (lower diagram)

IEC/IEEE bus commands :CALC:FEED 'TCAP'
:CALC:FORM FREQ
:DISP:WIND:TRAC:Y:SCAL:MODE ABS | REL
:CALC:DDEM:SPEC:STAT ON

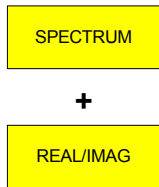

Simultaneously selecting the *SPECTRUM* and *REAL/IMAG* softkeys shows the FFT magnitude versus the real and imaginary component for the unprocessed signal in the *RECORD BUFFER*.

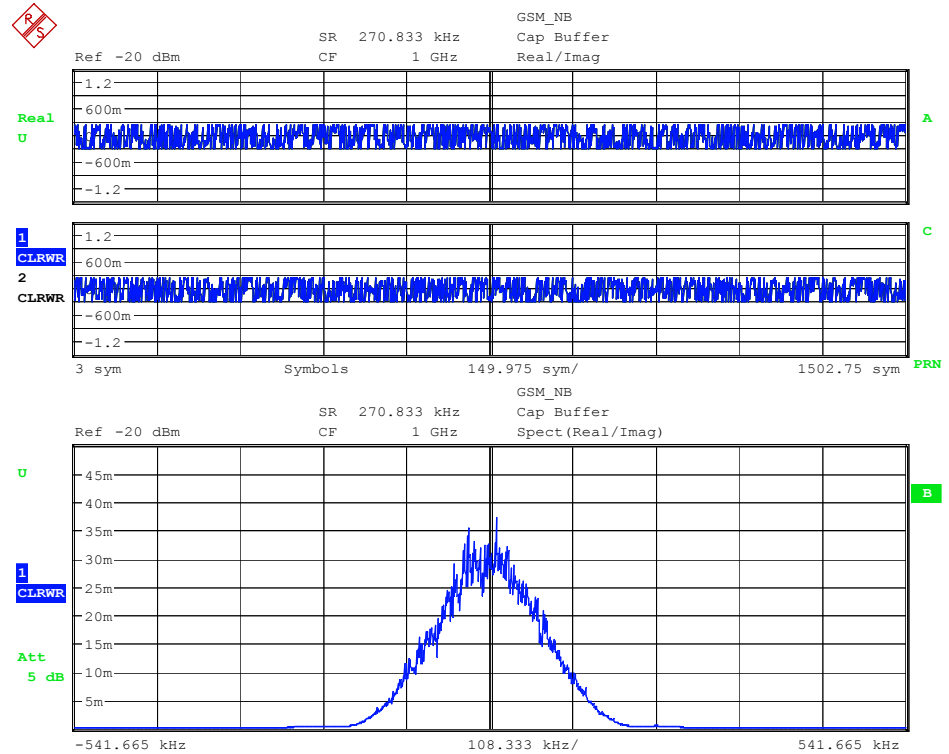

Date: 4.JUL.2003 07:47:09

Fig. 202 Result display CAPTURE BUFFER REAL/IMAG (upper diagram)
Result display SPECTRUM -> CAPTURE BUFFER REAL/IMAG (lower diagram)

IEC/IEEE bus commands :CALC:FEED 'TCAP'
:CALC:FORM RIM
:CALC:DDEM:SPEC:STAT ON

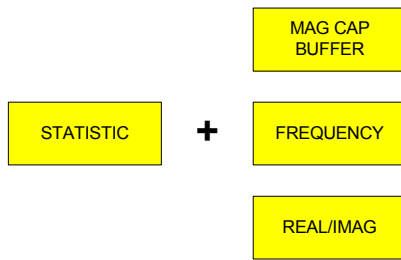

The *STATISTIC* softkey switches the set result display to a statistical evaluation of the result parameter.

Statistical evaluation is possible for the following result parameters:

- *MAGNITUDE CAPTURE BUFFER*
- *FREQUENCY CAPTURE BUFFER* (only for MSK and FSK modulation modes)
- *REAL/IMAG CAPTURE BUFFER*

The following diagrams provide examples of how the above parameters are displayed on screen. The x axis scaling including the unit (linear or logarithmic) is implemented by the y axis scaling of the corresponding measurement.

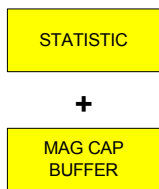

Simultaneously selecting the *STATISTIC* and *MAG CAP BUFFER* softkeys shows the frequency distribution of the amplitudes for the unprocessed signal in the *RECORD BUFFER*.

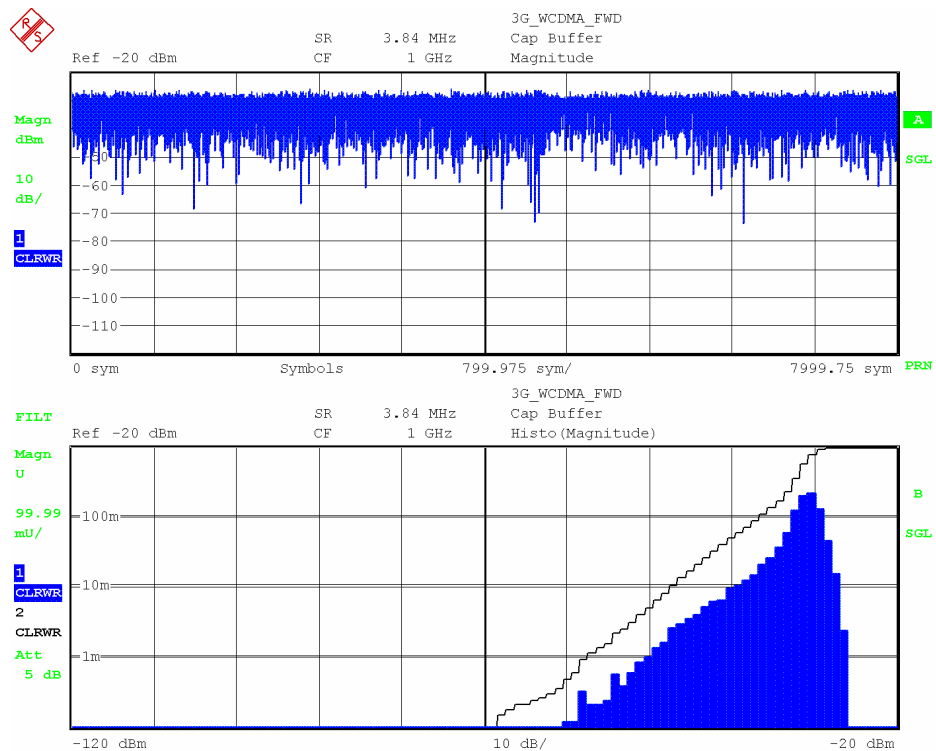

Date: 11.AUG.2003 09:24:48

Fig. 203 Result display *MAGNITUDE CAPTURE BUFFER* (upper diagram)
Result display *STATISTIC* -> *MAGNITUDE CAPTURE BUFFER* (lower diagram)

IEC/IEEE bus commands :CALC:FEED "TCAP"
:CALC:FORM MAGN
:CALC:STAT:CCDF:STAT ON

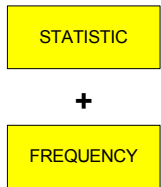

Simultaneously selecting the *STATISTIC* and *FREQUENCY* softkeys shows the frequency distribution of the frequency for the frequency modulated signal in the *RECORD BUFFER*.

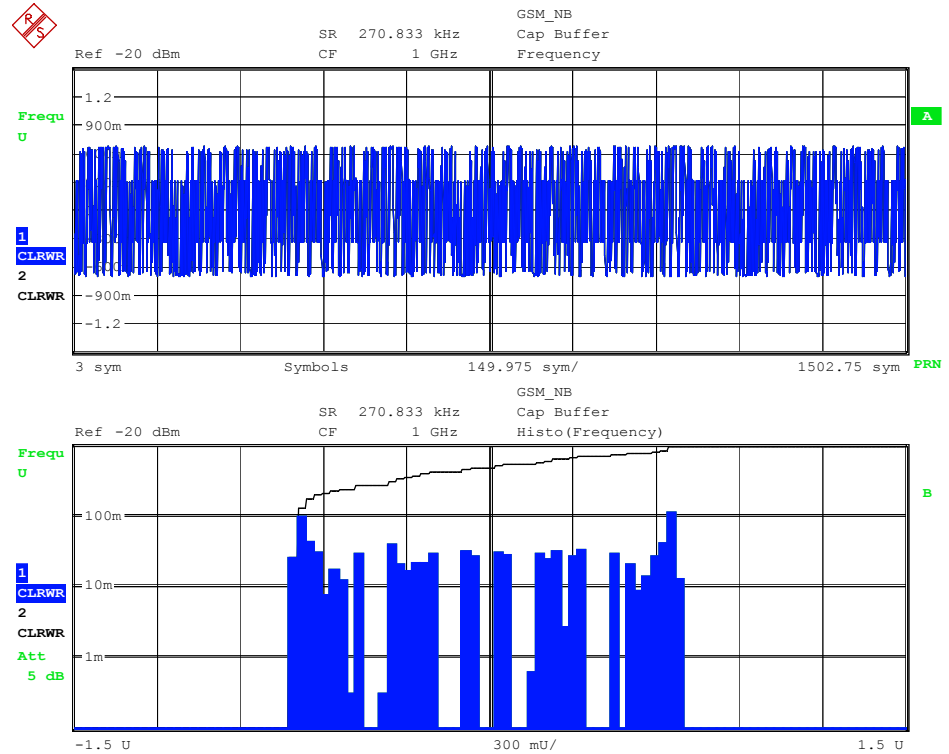

Date: 4.JUL.2003 07:44:51

Fig. 204 Result display *FREQUENCY CAPTURE BUFFER* (upper diagram)
Result display *STATISTIC -> FREQUENCY CAPTURE BUFFER* (lower diagram)

IEC/IEEE bus commands :CALC:FEED "TCAP"
:CALC:FORM FREQ
:DISP:WIND:TRAC:Y:SCAL:MODE ABS | REL
:CALC:STAT:CCDF:STAT ON

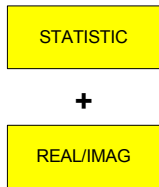

Simultaneously selecting the *STATISTIC* and *REAL/IMAG* softkeys shows the frequency distribution of real and imaginary component for the unprocessed signal in the *RECORD BUFFER*.

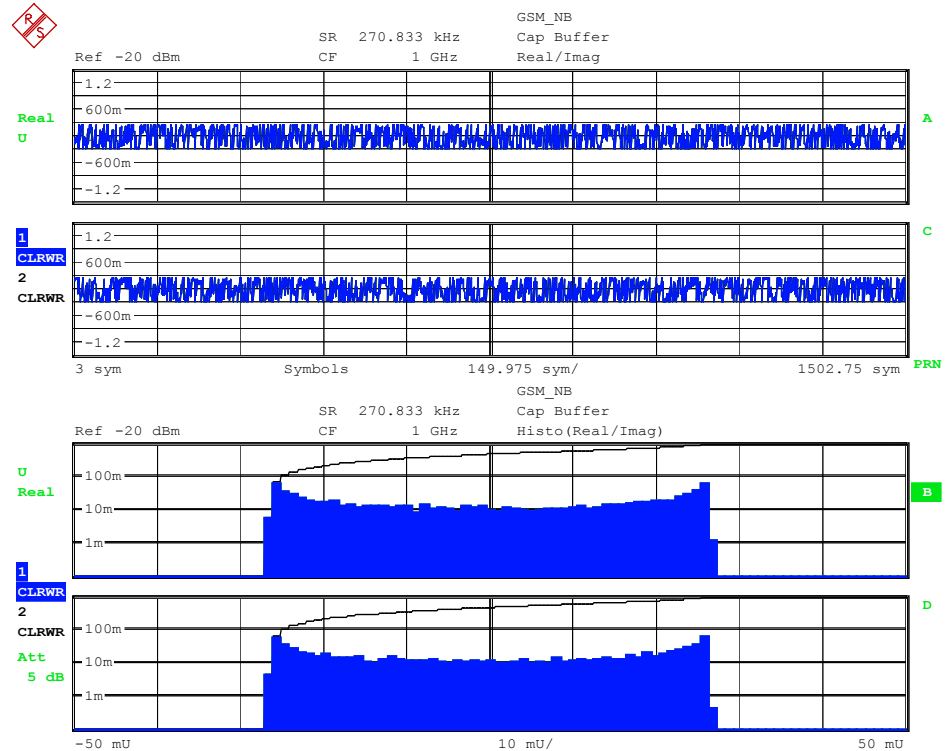

Date: 4.JUL.2003 07:48:05

Fig. 205 Result display *REAL/IMAG CAPTURE BUFFER* (upper diagram)
Result display *STATISTIC -> REAL/IMAG CAPTURE BUFFER* (lower diagram)

IEC/IEEE bus commands :CALC:FEED "TCAP"
:CALC:FORM RIM
:CALC:STAT:CCDF:STAT ON

Selection of Adaptive Equalizer Display - EQUALIZER Softkey

The adaptive equalizer generally has complex valued filter coefficients that can be displayed using the following modes:

Result calculation	Display	Comments
Impulse response (= filter coefficients)	Magnitude	Magnitude of the impulse response
	Real/Imag	Real- and imaginary part of the impulse response
	Phase	Angle of the impulse response
Frequency response (= FFT of filter coefficients)	Group Delay	Group Delay (of the transfer function)
	Phase Response	Angle of the transfer function
	Frequency Response	Magnitude of the transfer function
	Channel Response	Inverse Magnitude of the transfer function

Magnitude displays (magnitude, frequency response) can be scaled in linear or logarithmic y-axis. Phase displays (phase, phase response) are limited to the principal value range (wrap) or can be scaled to a freely adjustable range (unwrap).

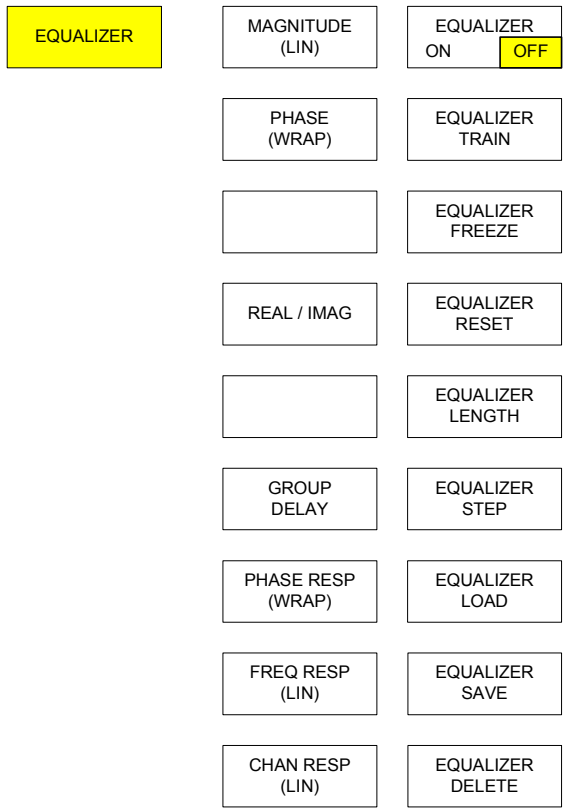

The softkey *EQUALIZER* opens a submenu for analyzing the filter coefficients of the adaptive equalizer. In an additional side-menu the equalizer control softkeys (*EQUALIZER SETTINGS*) are mirrored for convenience. (see softkey: *Equalizer Settings / menu MODULATION SETTINGS*)

A more detailed explanation of the equalizer's functionality can be found in the section 'Adaptive Equalizer Filter'.



The softkey *MAGNITUDE* sets the result display to show the magnitude of the equalizer's impulse response (= magnitude of filter coefficients). If *EQUALIZER = OFF* is set, a neutral filter is displayed.

LIN linear scaling of the y-axis.

LOG logarithmic scaling of the y-axis (dB)

The x-axis is scaled in ,symbols' in the range of:

$$\left[-\frac{\text{Equalizer_Length}}{2} \dots +\frac{\text{Equalizer_Length}}{2} \right]$$

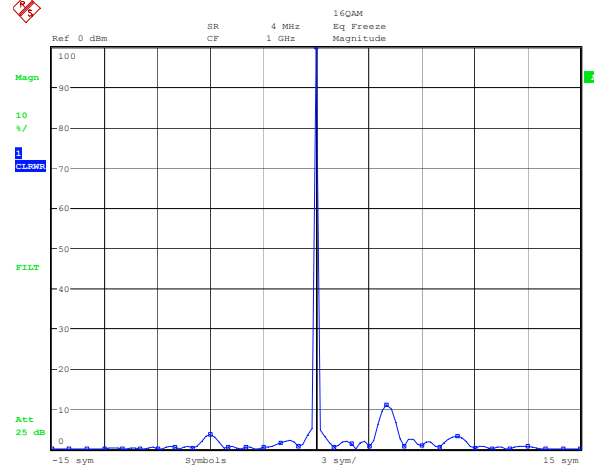

Fig. 206 Display of the filter coefficients *MAGNITUDE (LIN)*

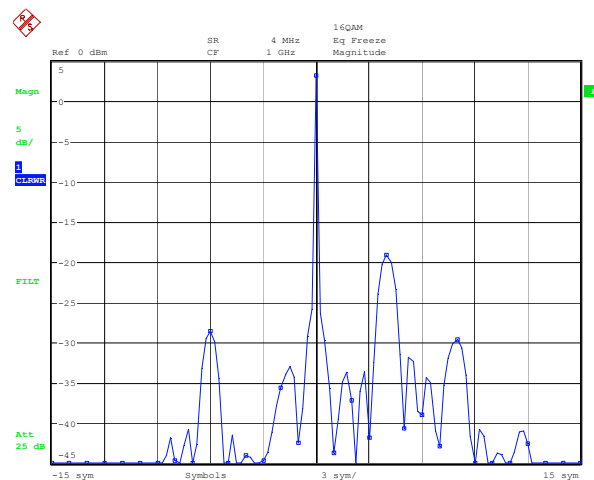

Fig. 207 Display of the filter coefficients *MAGNITUDE (LOG)*

```
IEC bus commands LOG:CALC:FEED 'XTIM:DDEM:IMP'
CALC:FORM MAGN
DISP:TRAC:Y:SPAC LOG
LIN:CALC:FEED 'XTIM:DDEM:IMP'
CALC:FORM MAGN
DISP:TRAC:Y:SPAC LIN
```

The softkey *PHASE* sets the result display to show the phase of the equalizer's impulse response (= phase of coefficients)
If *EQUALIZER = OFF* is set, a neutral filter is displayed. (Phase = 0).

PHASE
(WRAP / UNWR)

WRAP The display is limited to the value range of 2pi.
UNWRAP Also phase characteristics >2pi are displayed

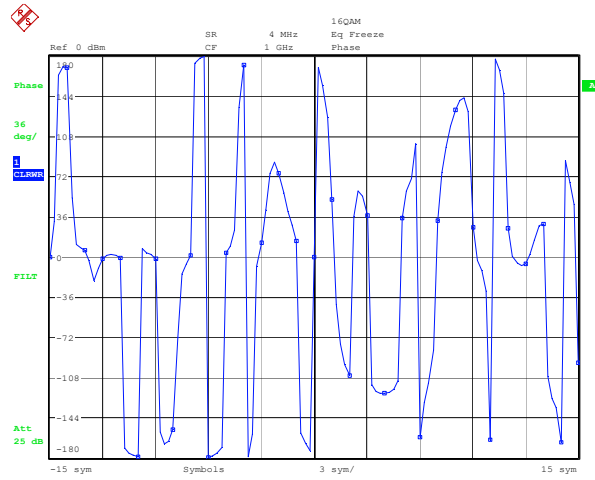

Fig. 208 Result display *PHASE(WRAP)*

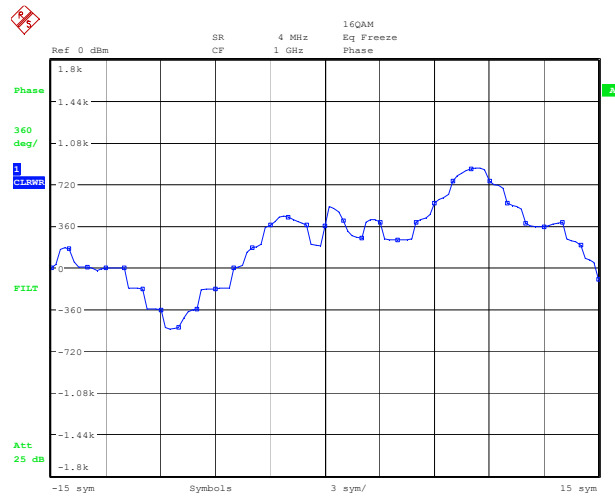
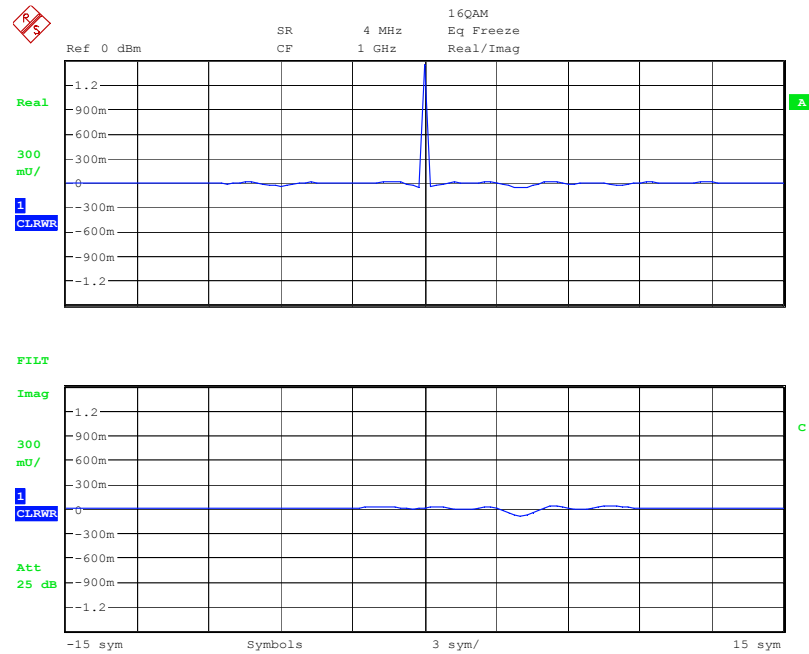

Fig. 209 Result display *PHASE(UNWRAP)*

```
IEC bus commands WRAP: CALC:FEED 'XTIM:DDEM:IMP'
CALC:FORM PHAS
UNWRAP: CALC:FEED 'XTIM:DDEM:IMP'
CALC:FORM UPH
```

REAL / IMAG

The softkey *REAL/IMAG* sets the result display to show the complex impulse response. If *EQUALIZER = OFF* is set, a neutral filter is displayed. The upper diagram draws the real part, the lower diagram the imaginary part of the complex valued impulse response.



Date: 12.JUL.2005 06:50:19

Fig. 210 Display result REAL/IMAG (impulse response = equalizer's filter coefficients)

IEC bus commands `CALC:FEED 'XTIM:DDEM:IMP'`
`CALC:FORM RIM`

GROUP
DELAY

The softkey *GROUP DELAY* sets the result display to show the equalizer's group delay.
If EQUALIZER = OFF is set, a neutral filter is displayed (group delay = 0).

The x-axis is scaled in Hz in the range of:

$$\left[-\frac{\text{points/symbol} \cdot \text{symbolrate}}{2} \dots + \frac{\text{points/symbol} \cdot \text{symbolrate}}{2} \right]$$

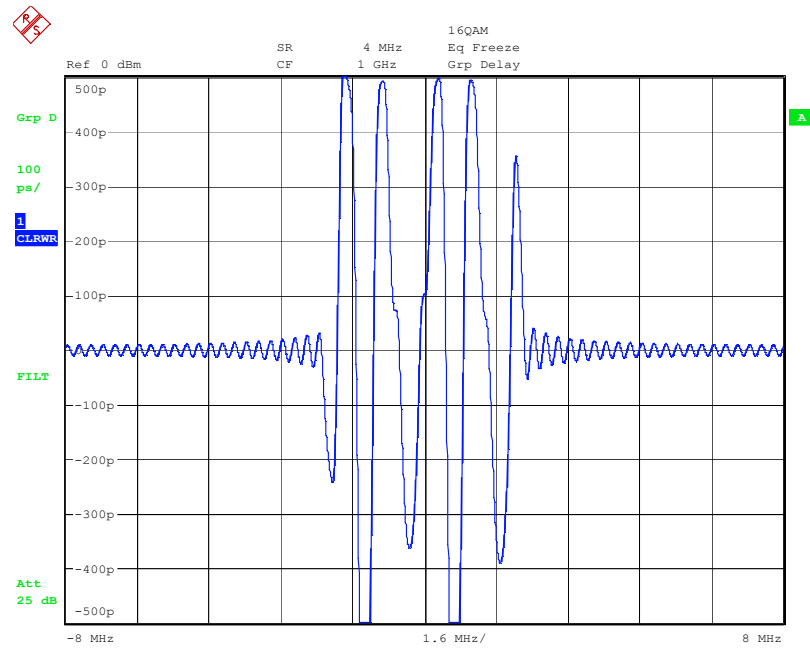

Date: 12.JUL.2005 06:53:41

Fig. 211 Result display *GROUP DELAY*

IEC bus commands `CALC:FEED 'XFR:DDEM:RAT'`
`CALC:FORM GDEL`

PHASE RESP
(WRAP / UNWR)

The softkey *PHASE RESPONSE* sets the result display to show the phase of the equalizer's frequency response. If *EQUALIZER = OFF* is set, a neutral filter is displayed (phase = 0).

WRAP The display is limited to the value range of 2π .
UNWRAP Also phase characteristics $>2\pi$ can be displayed

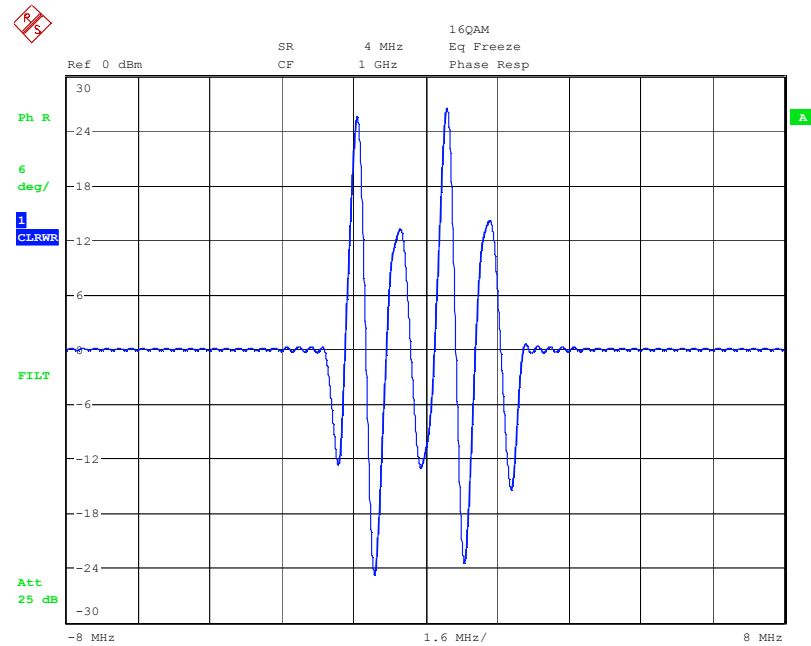

Date: 12.JUL.2005 06:54:40

Fig. 212 Result display *PHASE RESPONSE*

IEC bus commands

WRAP: CALC:FEED 'XFR:DDEM:RAT'
 CALC:FORM PHAS
UNWRAP: CALC:FEED 'XFR:DDEM:RAT'
 CALC:FORM UPH

FREQ RESP
(LIN / LOG)

The softkey *FREQ RESP* sets the result display to show the magnitude of the equalizer's frequency response.
If *EQUALIZER = OFF* is set, a neutral filter is displayed (magnitude = 1 or 0 dB respectively).

LIN linear scaling of the y-axis.

LOG logarithmic scaling of the y-axis (dB)

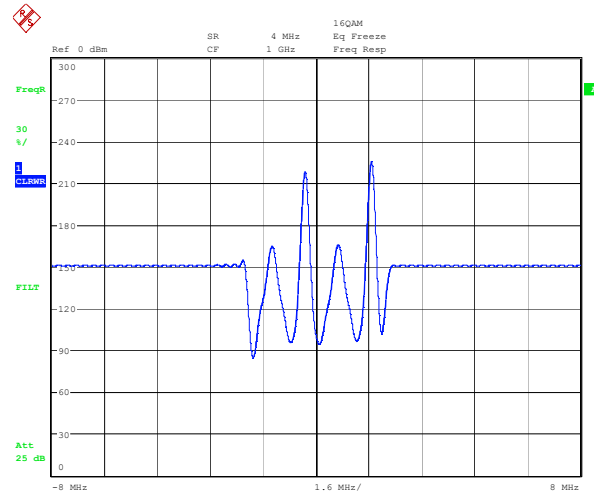

Fig. 213 Result display *FREQ RESP (LIN)*

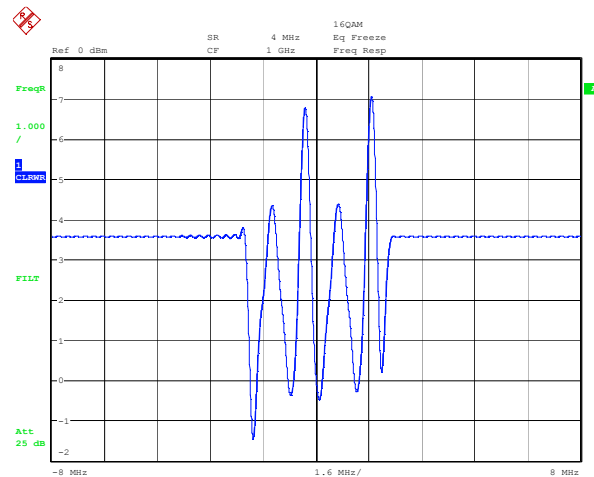

Fig. 214 Result display *FREQ RESP (LOG)*

IEC bus commands

```
LOG:    CALC:FEED 'XFR:DDEM:RAT
        CALC:FORM MAGN
DISP:   TRAC:Y:SPAC LOG
LIN:    CALC:FEED 'XFR:DDEM:RAT'
        CALC:FORM MAGN
        DISP:TRAC:Y:SPAC LIN
```

CHAN RESP
(LIN / LOG)

The softkey *CHAN RESP* sets the result display to show frequency response of the DUT.

It is calculated from the inverse frequency response of the equalizer filter and is only valid within the bandwidth of the transmit and receive filter respectively. If *EQUALIZER = OFF* is set, a neutral filter is displayed (magnitude = 1, respectively 0 dB).

LIN linear scaling of the y-axis.

LOG logarithmic scaling of the y-axis (dB)

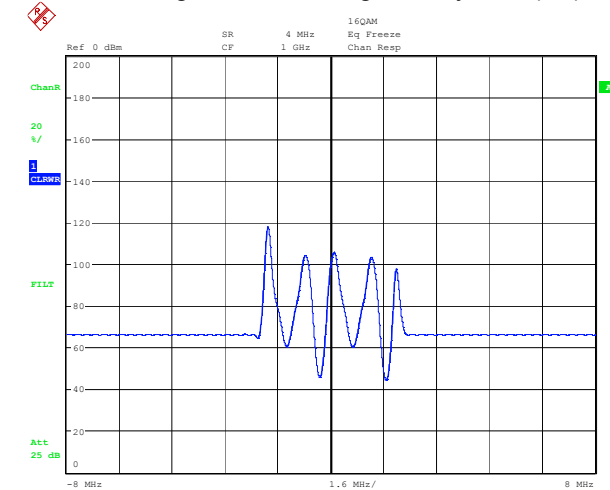
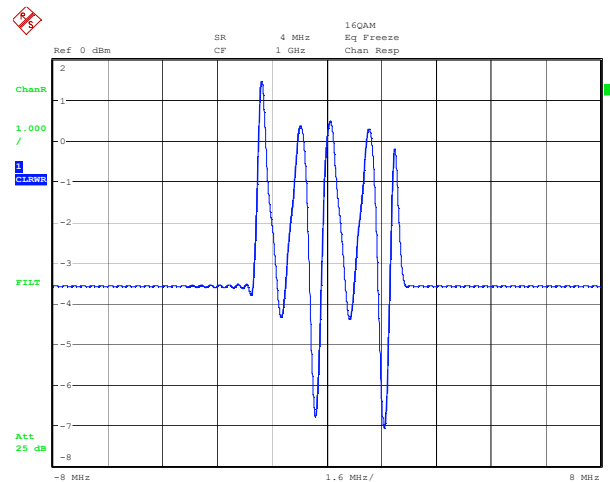

Fig. 215 Result display *CHAN RESP (LIN)*



Date: 12.JUL.2005 06:57:22

Fig. 216 Result display *CHAN RESP (LOG)*

IEC bus commands

```
LOG:    CALC:FEED 'XFR:DDEM:IRAT'
        CALC:FORM MAGN
DISP:   TRAC:Y:SPAC LOG
LIN:    CALC:FEED 'XFR:DDEM:IRAT'
        CALC:FORM MAGN
DISP:   TRAC:Y:SPAC LIN
```

Positioning of Display on Screen - FIT TRACE Softkey

This section describes the different spans if FIT settings are used.

The analyzer determines the demodulation range of signal processing (DSP_Demod_Range) after the instrument has been set. See chapter "[Record Buffer, Demodulation Range and Display Range](#)" for examples.

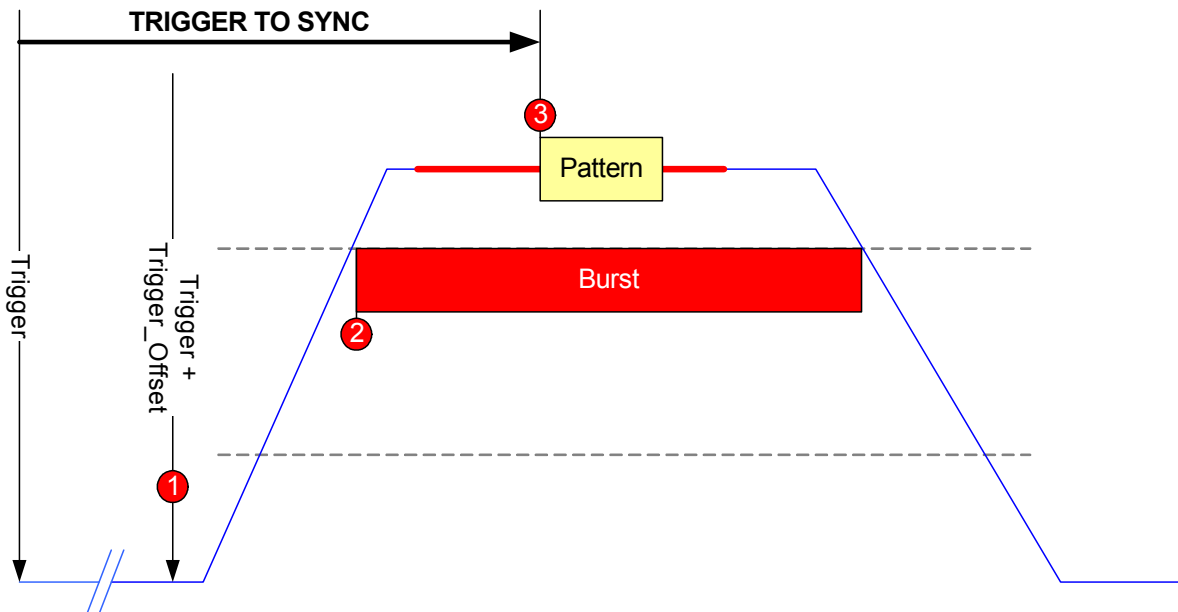

Fig. 217 Burst measurement by using an external trigger

Fig. 217 shows a burst measurement example when an external trigger is used. Burst search is activated, and a synchronization pattern was found.

The *TRIGGER TO SYNC* result parameter is derived from the time difference between synchronization pattern and external trigger time.

Positioning of the screen display is possible via the marked reference points (see above):

Trigger + Trigger_Offset
 Burst
 Pattern

Possible settings are:

- **FIT TO LEFT.** In this setting, the reference point (trigger, **start** of burst or **start** of pattern) is positioned to the left edge of the screen display.
- **FIT TO CENTER:** The reference point (trigger, burst **center**, pattern **center**) is positioned to the **center** of the screen display.
- **FIT TO RIGHT:** The reference point (trigger, **end** of burst, **end** of pattern) is positioned to the right edge of the screen display.

Examples are shown in the figures below.

Examples of FIT BURST, FIT PATTERN and FIT TRIGGER

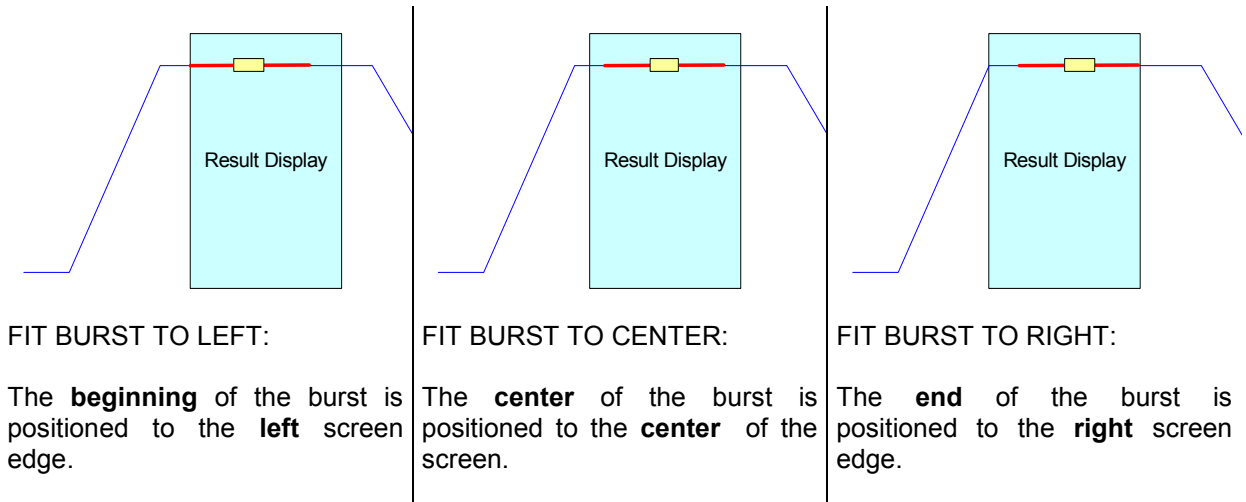

Fig. 218 Examples of FIT: Fit Burst to Left / Center / Right

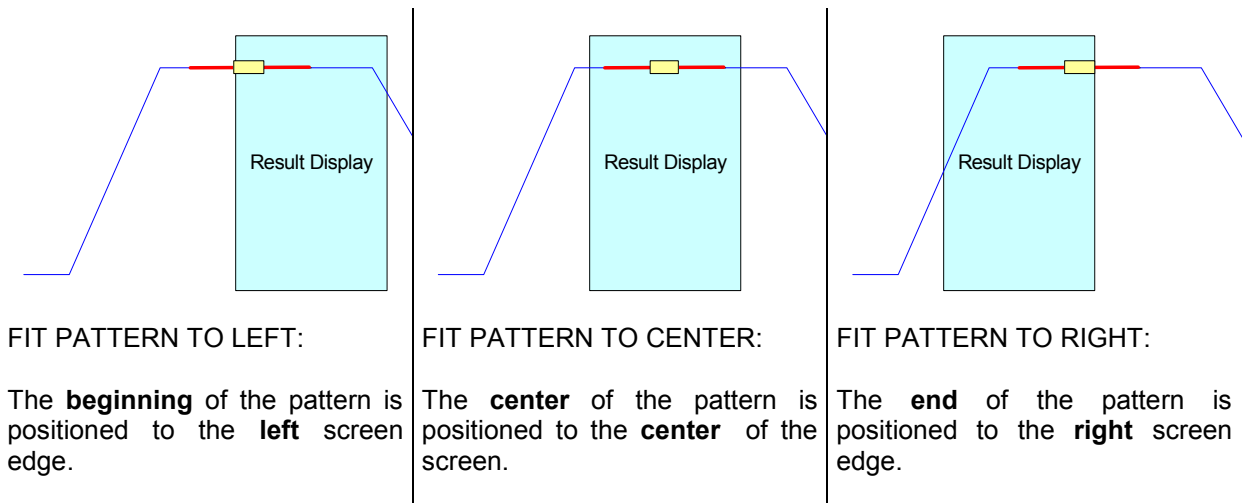
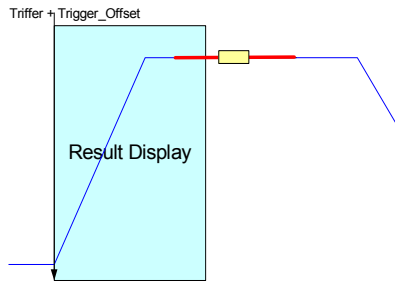

Fig. 219 Examples of FIT: Fit Pattern to Left / Center / Right



FIT BURST TO TRIGGER:

The left screen edge is positioned to the TRIGGER+ TRIGGER_OFFSET reference point.

Fig. 220 Examples of FIT: Fit Burst to Trigger

For FIT BURST TO TRIGGER only setting LEFT is available. Fine adjustment and manual shifting with FIT ALIGN or FIT OFFSET is not possible.

Fine adjustment using FIT ALIGN

FIT ALIGN allows manual shifting of the screen display (with reference to the selected reference point). Entry is in [%] of the screen width. A corresponding symbol setting can be set by means of the **FIT OFFSET** softkey.

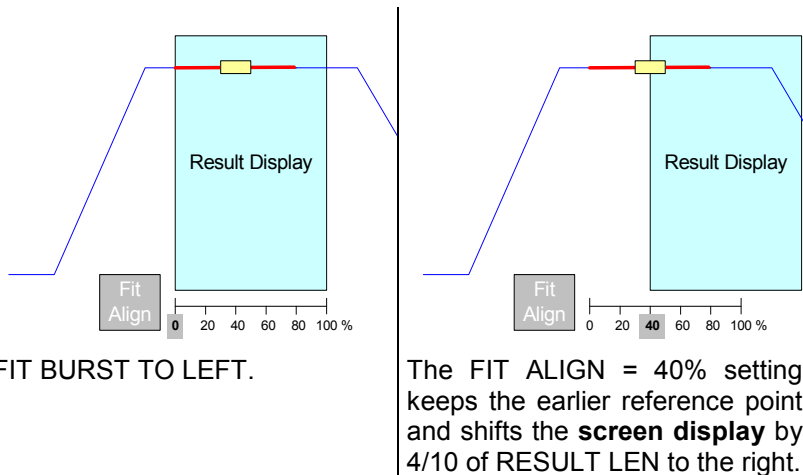

FIT BURST TO LEFT.

The FIT ALIGN = 40% setting keeps the earlier reference point and shifts the **screen display** by 4/10 of RESULT LEN to the right.

Fig. 221 Examples of FIT: Fit Align

Scaling of Time Axis in Symbols

The zero point on the time or symbol axis can be matched within wide limits to the measurement requirements.

If a symbol cannot be numbered by means of the pattern search and standard definition, the following are assigned the symbol number "0" (depending on the selected reference point):

- beginning of a burst
- reference point trigger + trigger offset

This scale reference point is maintained even if the display is shifted.

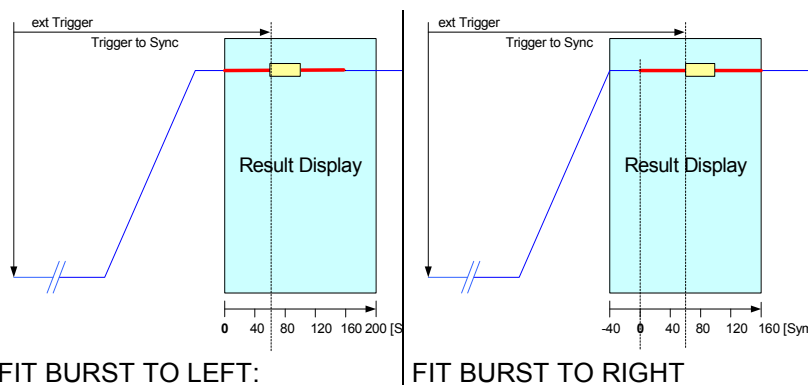

FIT BURST TO LEFT:

FIT BURST TO RIGHT

Fig. 222 Examples of FIT: scaling of time axis

A similar behaviour occurs with pattern-related measurements if the symbol number is specified by a digital standard definition.

Example: Because a standard was defined, the position number of the first pattern symbol is set to "53 (decimal)". This definition then applies to all positionings (left/center/right). The measured value for TRIGGER TO SYNC is obtained from the difference between external trigger time and beginning of pattern, independent of the positionings on the screen.

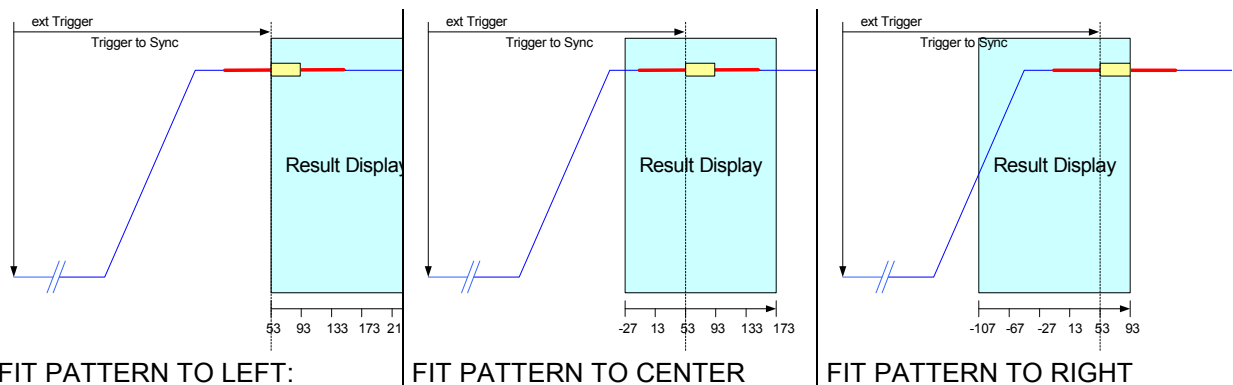

FIT PATTERN TO LEFT:

FIT PATTERN TO CENTER

FIT PATTERN TO RIGHT

Fig. 223 Examples of FIT: labelling of symbol axis

FIT TRACE Menu

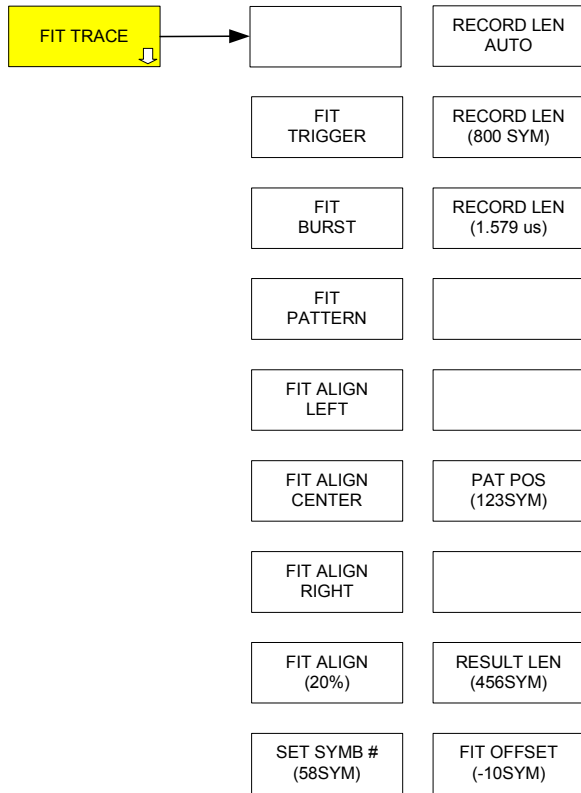

The FIT TRACE softkey opens the menu for positioning the measurements results on the display.

The reference point is selected by using the softkey group

FIT TRIGGER

FIT BURST

FIT PATTERN

The reference point is positioned on the display by using the key group:

FIT ALIGN LEFT

FIT ALIGN CENTER

FIT ALIGN RIGHT

Positioning can be shifted by using the parameter

FIT ALIGN (input in %) or

FIT OFFSET (input in symbols)

Softkey SET SYMB # assigns a symbol number to the reference points

- start of USEFUL LENGTH

- trigger and trigger offset

In addition, the side menu allows *RECORD LEN* and *RESULT LEN* parameter settings.

PAT POS (pattern position) specifies the expected position of the start of the pattern relative to the start of the *USEFUL LENGTH*. The analyzer searches for the pattern in a range between (pattern position) and (pattern position + pattern length) with a tolerance of +/- 5 symbols.

For setting examples, see previous chapter.

IEC/IEEE bus commands

```
:CALC:TRAC:ADJ TRIG|BURS|PATT
:CALC:TRAC:ADJ:ALIG LEFT|CENT|RIGH
:CALC:TRAC:ADJ:ALIG:VAL <num_value>
:CALC:TRAC:ADJ:ALIG:OFF <num_value>
:DISP:WIND:TRACe:X:SCAL:VOFF <num>
:SENS:DDEM:STAN:SYNC:OFFS <num_val>
```

Multiple Evaluation and Section Displays - ZOOM Softkey



ZOOM
START

The *ZOOM* softkey opens the menu for setting the display area of the capture buffer and for controlling demodulation in multi-processing mode.

ZOOM
LENGTH

The following softkeys determine which area of the capture buffer to display:

- *ZOOM START*
- *ZOOM LENGTH*

DEMOD
NEXT RIGHT

DEMOD
RESTART

IEC/IEEE bus command : SENS : DDEM : SEAR : MBUR : STAR
500SYM

DEMOD @
ZOOM START

: SENS : DDEM : SEAR : MBUR : LENG 1000SYM

The following softkeys control demodulation in multiple evaluation mode:

- *DEMOD NEXT RIGHT*
- *DEMOD RESTART*
- *DEMOD @ ZOOM START*

CAPTURE
AUTO OFF

MULTI
ON OFF

These softkeys are available only in MULTI mode in conjunction with SINGLE SWEEP. You can find a detailed description of this control (also for demodulation of burst signals) in the section "[Multiple Evaluation of a Captured Data Record \(MULTI\)](#)".

IEC/IEEE bus command : SENS : DDEM : SEAR : MBUR : FIND : NEXT
: SENS : DDEM : SEAR : MBUR : FIND : FIRS
: SENS : DDEM : SEAR : MBUR : FIND : STAR

The following softkey starts automatic data capture if the end of the record buffer has been reached:

- *CAPTURE AUTO / OFF*

If *CAPTURE OFF* is selected, data capture will not be started. When the end of the record buffer is reached, the message '**End of Buffer**' will be output. This softkey is available only in MULTI mode in conjunction with SINGLE SWEEP.

IEC/IEEE bus command : SENS : DDEM : SEAR : MBUR : CAP : AUTO
OFF

The following softkey switches **multiple evaluation mode** on and off ("[Multiple Evaluation of a Captured Data Record \(MULTI\)](#)"):

- *MULTI ON/OFF*

If MULTI ON is selected, a new capture is performed once the end of the record buffer has been reached. Otherwise, the message '**End of Buffer**' will be output.

IEC/IEEE bus command : SENS : DDEM : SEAR : MBUR ON

Setting of Span - RANGE Softkey

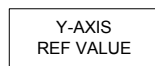
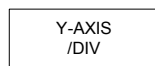
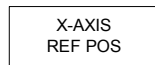
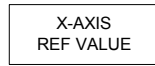
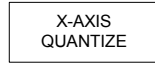

The *RANGE* softkey opens a menu for setting the display scaling and the span.

Scaling of the x axis for **I/Q and statistical displays** is controlled by the following softkeys:

- X-AXIS /DIV*
- X-AXIS REF VALUE*
- X-AXIS REF POS*
- X-AXIS LIN / LOG*

These softkeys are not available for time display since other operating parameters (RESULT LENGTH, FIT) determine the zero point and scaling.

The following softkeys control the zero point and scaling of the y axis for **I/Q, statistical and time displays**:

- Y-AXIS /DIV*
- Y-AXIS REF VALUE*
- Y-AXIS REF POS*

The following softkey controls quantization of the x axis in **statistical displays**:

- X-AXIS QUANTIZE*

The following sofkey restores the default setting of the current measurement window:

- DEFAULT SETTINGS*

IEC/IEEE bus commands

```
:CALC:STAT:SCAL:X:BCO <num_value>
:DISP:WIND:TRAC:X:SCAL:PDIV <num_value>
:DISP:WIND:TRAC:X:SCAL:RVAL <num_value>
:DISP:WIND:TRAC:X:SCAL:RPOS <num_value>
:DISP:WIND:TRAC:X:SPAC LIN | LOG
:DISP:WIND:TRAC:Y:SCAL:PDIV <num_value>
:DISP:WIND:TRAC:Y:SCAL:RVAL <num_value>
:DISP:WIND:TRAC:Y:SCAL:RPOS <num_value>
```

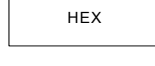
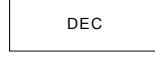

The **SYMBOLS & MOD ACC** display mode is used to switch the symbol value display in the *RANGE* submenu between:

- Binary*
- Octal*
- Decimal*
- Hexadecimal*

The selection of the display mode also affects the number of displayed symbols.

IEC/IEEE bus command: -

Examples:

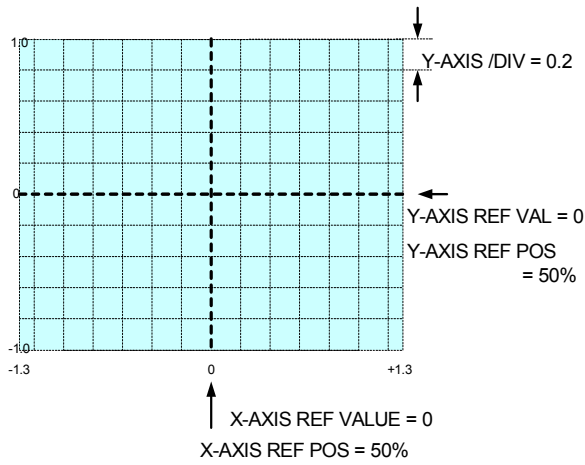

Fig. 224 Example of RANGE, I/Q display X AXIS/DIV is used together with Y AXIS/DIV.

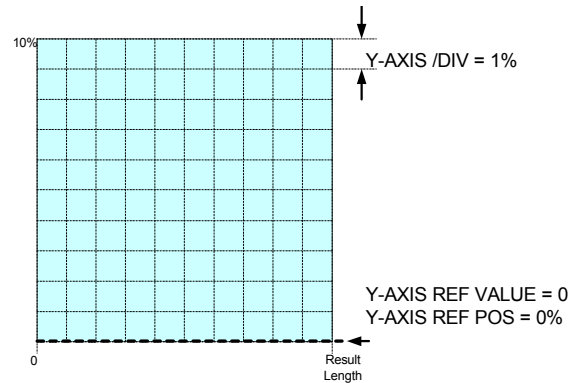

Fig. 225 Example of RANGE, time display (EVM lin)

Time displays and log scale (Mag Cap Buffer ...)

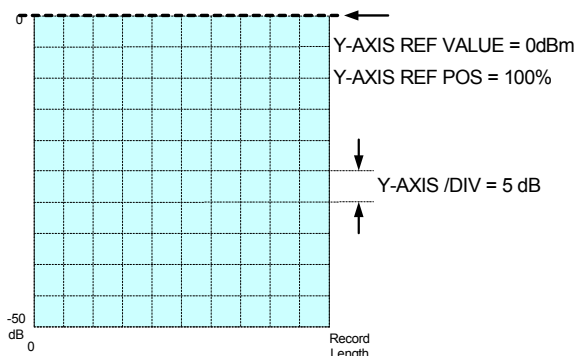

Fig. 226 Example of RANGE, time display, Mag Cap Buffer

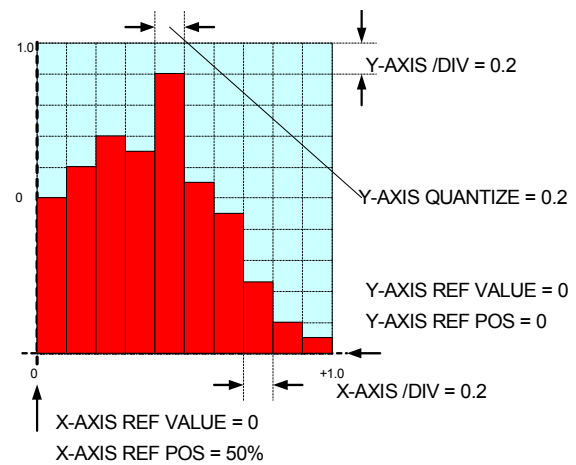



Fig. 227 Example of RANGE, statistical display Quantize

Automatic Setting of Reference Level - ADJUST LVL Softkey

A yellow rectangular button with the text "ADJUST REF LVL" in black, representing the softkey used for automatic reference level adjustment.

The *ADJUST REF LVL* softkey sets the signal-adjusted reference level to the optimum setting value, taking into account an overload reserve.

A keystroke activates a setting that is performed once and does NOT provide continuous adjustment of the set level. After significant level changes of the applied input signal, or as a result of overload display, a reset is required to eliminate measurement errors due to insufficient dynamic range or overload.

In operating mode TRIGGER = FREE RUN the signal peak value within an observation period of 0.2 sec (or of the RECORD TIME if this time is longer) is determined, which in turn is required to determine the necessary instrument settings. In a subsequent control measurement using adapted instrument settings, the values are checked and the instrument settings improved until the measured peak value is in a range between the set reference level and 5 dB below the reference level.

If an external trigger is active, the described sequence is invoked by triggered measurements with the set RECORD TIME.

If the slower periodicity signal varies, a manual reference level setting is recommended (see **Level Settings - Key AMPT -> REF LEVEL**).

To protect the instrument input against overload, the attenuator is limited to a minimum setting value of 10 dB when using the RF ATTEN AUTO setting.

When the attenuation is set manually using RF ATTEN MAN, the current attenuation setting is not undershot.

IEC/IEEE bus command : SENS : DDEM : PRES : RLEV

Restoring of Factory Settings - FACTORY DEFAULTS Softkey

FACTORY
DEFAULTS

GENERIC
STANDARDS

STANDARDS

MAPPINGS

PATTERN

FILTER

ALL

The *FACTORY DEFAULTS* softkey restores the factory settings of the following parameters for the R&S FSQ-K70/FSMR-B73/FSU-B73 option:

GENERIC STANDARDS

STANDARDS

MAPPINGS

PATTERN

FILTER

ALL restores the factory settings of all of the above parameters.

All functions request a confirmation. If the answer is "yes", **parameters of the same name** (e.g. pattern) will be overwritten without any further individual queries.

IEC/IEEE bus command: :SENS:DDEM:FACT GST

Importing Stand., Mappings, Pattern and Filter - IMPORT Softkey

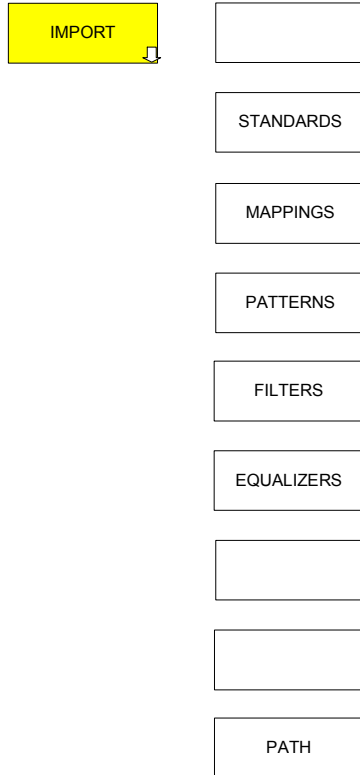

The *IMPORT* softkey can be used to transfer the following from other R&S analyzers or from external programs (MAPWIZ, FILTWIZ) via file operations:

- *STANDARDS*
- *MAPPINGS*
- *PATTERNS*
- *FILTERS*
- *EQUALIZER FILTER*

PATH is used to set the path under which to search for external data. By default, this path points to the built-in disk drive.

All functions include a confirmation query. If a confirmation query is answered with "yes", **an existing file of the same name** will be overwritten (e.g. pattern file).

After the appropriate softkey is pressed, the path that is entered will be searched to find matching files of this type, and the files that are found will be displayed in a table. The cursor keys or rotary knob are used to make a selection. The file is copied to the instrument by confirming with the ENTER key. If no matching files are found in the path, a blank table will be displayed. It can be exited with ESC.

If standards are imported (*STANDARDS* softkey), the following items for each standard are also imported:

- Patterns
- Filters
- Mappings
- Equalizer Filter

If the confirmation query is answered with "yes" when standards are imported, all **existing files of the same name** will be overwritten without additional confirmation queries.



The *STANDARDS* softkey shows the table of digital standards available in the selected path.



Fig. 228 Selection list of digital standards EXPORT -> STANDARDS

IEEE/IEC bus command: SENS:DDEM:IMP:STAN <name>, <path>

MAPPINGS

The MAPPINGS softkey shows the table of mappings available in the selected path.

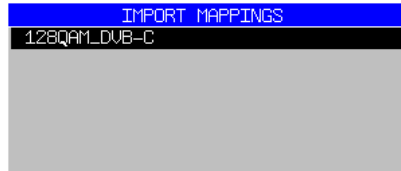

Fig. 229 Selection list of symbol mappings IMPORT -> MAPPINGS

IEEE/IEC bus command: SENS:DDEM:IMP:MAPP <name>,<path>

FILTERS

The FILTERS softkey shows the table of filters available in the selected path. No distinction is made between transmit, receive or measurement filters.

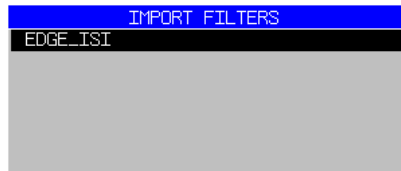

Fig. 230 Selection list of filters IMPORT -> FILTERS

IEEE/IEC bus command: SENS:DDEM:IMP:FILT <name>,<path>

EQUALIZERS

The EQUALIZERS softkey shows the table of equalizer filters available in the selected path. Only equalizer filters are listed, no transmit, receive or measurement filters.



Fig. 231 Selection list of filters IMPORT -> EQUALIZER

IEEE/IEC bus command: SENS:DDEM:IMP:EQU <name>,<path>

PATTERNS

The PATTERNS softkey shows the table of patterns available in the selected path.



Fig. 232 Selection list of synchronization patterns IMPORT -> PATTERNS

IEEE/IEC bus command: SENS:DDEM:IMP:PATT <name>,<path>

PATH

The PATH softkey sets the path for the IMPORT function. The path is factory-set to the built-in disk drive. The setting also affects the EXPORT function.

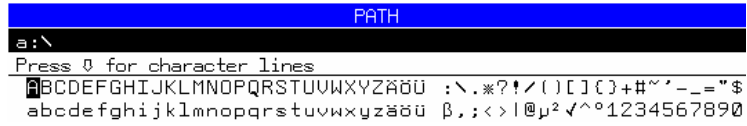
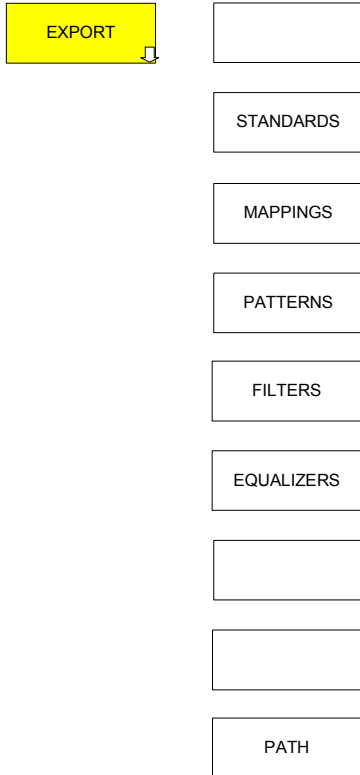

Fig. 233 Selection of path IMPORT -> PATH

IEEE/IEC bus command-
(the path is specified when the parameters are selected)

Export of Stand., Mappings, Pattern and Filter - EXPORT Softkey



The *EXPORT* softkey can be used to transfer the following from other R&S FSQ analyzers or from external programs (MAPWIZ, FILTWIZ) via file operations:

- *STANDARDS*
- *MAPPINGS*
- *PATTERNS*
- *FILTERS*
- *EQUALIZERS*

PATH is used to set the path to which the internal files are to be copied. This path usually points to the built-in disk drive.

After the appropriate softkey is pressed, the existing internal files of the selected type are listed in a table. The cursor keys or rotary knob are used to make a selection. Pressing the ENTER key as confirmation copies the file to the diskette (or to another data medium that is connected). If no matching files are found in the instrument, a blank table will be displayed. It can be exited with ESC.

When standards are saved, also the following items associated with the standard are saved in compressed format:

- Patterns
- Filters
- Mappings
- Equalizers

They do not appear as separate files in the corresponding individual selections.



The *STANDARDS* softkey. shows the table of digital standards available in the instrument.

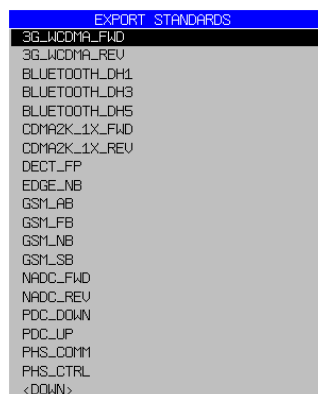

Fig. 234 Selection list of digital standards EXPORT -> STANDARDS

IEEE/IEC bus commands :SENS:DDEM:EXP:GST <name>,<path>
:SENS:DDEM:EXP:STAN <name>,<path>

MAPPINGS

The MAPPINGS softkey shows the table of mappings available in the instrument.



Fig. 235 Selection list of symbol mappings EXPORT -> MAPPINGS

IEEE/IEC bus command: SENS:DDEM:EXP:MAPP <name>,<path>

FILTERS

The FILTERS softkey shows the table of filters available as coefficients in the instrument. Analytic filters (root raised cosine, raised cosine, Gaussian) are calculated at runtime in the instrument and cannot be exported.



Fig. 236 Selection list of filters EXPORT -> FILTERS

IEEE/IEC bus command: SENS:DDEM:EXP:FILT <name>,<path>

EQUALIZERS

The *EQUALIZERS* softkey shows the table of equalizer filters available in the instrument. Only equalizer filters are listed, but no transmit, receive or measurement filters.



Fig. 237 Selection list of filters EXPORT -> EQUALIZER

IEEE/IEC bus command: SENS:DDEM:EXP:EQU <name>,<path>

PATTERNS

The *PATTERNS* softkey shows the table of patterns available in the instrument.



Fig. 238 Selection list of synchronization patterns EXPORT -> PATTERNS

IEEE/IEC bus command: SENS:DDEM:EXP:PATT <name>,<path>

PATH

The *PATH* softkey sets the path for the EXPORT function. The path is factory-set to the built-in disk drive. The setting also affects the IMPORT function..

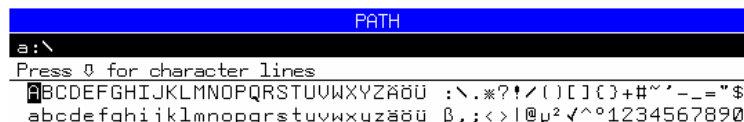

Fig. 239 Selection of the path EXPORT -> PATH

IEEE/IEC bus command-
(the path is specified when the parameters are selected)

Overview of Other Menus

Operation of the other keys is very similar to that of the basic unit. Please note that some functions implemented in the basic unit are **not available** here. Such functions are only briefly mentioned in the following; for a detailed description refer to the manual of the basic unit.

The IEC/IEEE bus commands of the menus described below are found in the "Table of Softkeys Assigned to IEC/IEEE Bus Commands".

Any R&S FSQ-K70/FSMR-B73/FSU-B73-specific softkeys or menus **added** to extend the range of control functions are described in detail.

Default Settings - PRESET Key



The *PRESET* key resets the analyzer to the spectrum analyzer mode and activates the default settings of this mode.

The current settings of the VSA mode will be lost, too, because the R&S FSQ-K70/FSMR-B73/FSU-B73 option is also reset to a default status.

IEC/IEEE bus command: *RST

System Error Correction - CAL Key

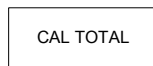

The functions of the softkeys of the *CAL* menu are identical to those of the corresponding softkeys of the basic unit:



CAL TOTAL Calculates the internal correction data of the instrument for system error correction.

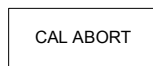

CAL ABORT Stops the collection of correction data.



CAL CORR ON/OFF Switches on or off system error correction by means of the calculated data.

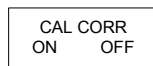

CAL RESULTS Displays a table of calculated correction values.

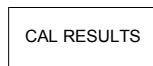

General Instrument Settings - SETUP Key

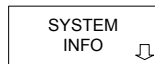
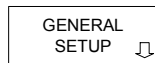
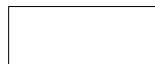
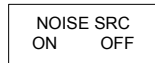

The functions of the softkeys of the *SETUP* menu are identical to those of the corresponding softkeys of the basic unit. The option-specific softkeys are additionally available under *SIGNAL PATH* (see below).

REFERENCE INT / EXT Switches between internal and external reference frequency.

NOISE SRC ON/OFF Switches on or off the supply voltage for an external noise voltage source.

SIGNAL SOURCE Selects the signal source for the Vector Signal Analyzer option (R&S FSQ-K70/FSMR-B73/FSU-B73).

GENERAL SETUP Opens a submenu where the instrument interfaces and the time of day can be configured and software options activated.

SYSTEM INFO Opens a submenu for the display of module data and system messages.

SERVICE Opens a submenu with functions for maintenance and troubleshooting.



YIG FILTER
ON OFF

RF PATH

BASEBAND
ANALOG

IQ INPUT
50 1k

BALANCED
ON OFF

LOW PASS
36 MHz

DITHER
ON OFF

The SIGNAL SOURCE softkey opens a submenu for selecting the input signal source for the R&S FSQ-K70 option:

YIG FILTER ON / OFF Connects a broadband YIG filter for image-frequency rejection into the signal path. The default setting for the R&S FSQ-K70 option is OFF. Frequency response and phase response of this filter are not corrected by instrument calibration. The softkey is only available on instrument models R&S FSQ8 and R&S FSQ26.

RFPATH Selects the RF input socket as a signal input.

The following softkeys are available only if the R&S FSQ-B71 option (baseband input) is installed (see manual of option for detailed description):

BASEBAND ANALOG Selects the analog IQ baseband inputs as a signal source.

IQ INPUT 50Ω / 1kΩ Switches the input impedance of the analog IQ inputs between 50 Ω and 1 kΩ.

BALANCED ON / OFF Switches the analog baseband inputs between **BALANCED** and **UNBALANCED** mode.

LOWPASS 36 MHz Connects an analog lowpass filter with 36 MHz cutoff frequency (for image-frequency rejection) into the signal paths of the baseband inputs.

DITHER ON / OFF Controls a dither generator for the reduction of mixture products on the A/D converter characteristic.

Documentation of Results - HCOPY Key

	<div style="border: 1px solid black; padding: 2px; width: fit-content; margin-bottom: 10px;">PRINT SCREEN</div> <div style="border: 1px solid black; padding: 2px; width: fit-content; margin-bottom: 10px;">PRINT TRACE</div> <div style="border: 1px solid black; padding: 2px; width: fit-content; margin-bottom: 10px;">PRINT TABLE</div> <div style="border: 1px solid black; padding: 2px; width: fit-content; margin-bottom: 10px;">HARDCOPY ABORT</div> <div style="border: 1px solid black; padding: 2px; width: fit-content; margin-bottom: 10px;">DEVICE 1</div> <div style="border: 1px solid black; padding: 2px; width: fit-content; margin-bottom: 10px;">DEVICE 2</div> <div style="border: 1px solid black; padding: 2px; width: fit-content; margin-bottom: 10px;">COLORS ↓</div> <div style="border: 1px solid black; padding: 2px; width: fit-content; margin-bottom: 10px;">COMMENT SCREEN A</div> <div style="border: 1px solid black; padding: 2px; width: fit-content; margin-bottom: 10px;">COMMENT SCREEN B</div> <div style="border: 1px solid black; padding: 2px; width: fit-content;">INSTALL PRINTER</div>	<p>The functions of the softkeys of the <i>HCOPY</i> menu are identical to those of the corresponding softkeys of the basic unit.</p> <p><i>PRINT SCREEN</i> Starts the printing of results (all diagrams, traces, markers, marker lists, etc displayed on the screen).</p> <p><i>PRINT TRACE</i> Starts the printing of all traces displayed on the screen WITHOUT including any further information.</p> <p><i>PRINT TABLE</i> Starts the printing of configuration tables and display lists WITHOUT including the underlying result diagrams and labelling.</p> <p><i>HARDCOPY ABORT</i> Stops the current printing job.</p> <p><i>DEVICE1 / DEVICE2</i> Selects one of two possible printers and opens a configuration table for the selected printer.</p> <p><i>COLORS</i> Opens a submenu for colour settings.</p> <p><i>COMMENT SCREEN A / B</i> Enables the input of a comment for screen A or screen B. Comments will not be displayed but appear only on the hardcopy.</p> <p><i>INSTALL PRINTER</i> Opens a dialog window for installation of a printer (side menu).</p>
---	---	---

In the case of averaged IQ displays such as IQ Constellation and EYE, the trace last measured is output in the hard copy function.

Frequency Settings - FREQ Key

	<div style="border: 1px solid black; padding: 2px; width: 80px; margin-bottom: 10px; text-align: center;">CENTER</div> <div style="border: 1px solid black; height: 25px; margin-bottom: 10px;"></div> <div style="border: 1px solid black; padding: 2px; width: 80px; margin-bottom: 10px; text-align: center;">CF STEP AUTO MAN</div> <div style="border: 1px solid black; padding: 2px; width: 80px; margin-bottom: 10px; text-align: center;">CF STEP SIZE</div> <div style="border: 1px solid black; height: 25px; margin-bottom: 10px;"></div> <div style="border: 1px solid black; padding: 2px; width: 80px; margin-bottom: 10px; text-align: center;">FREQUENCY OFFSET</div> <div style="border: 1px solid black; height: 25px; margin-bottom: 10px;"></div> <div style="border: 1px solid black; height: 25px;"></div>	<p>The functions of the softkeys of the <i>FREQUENCY</i> menu are identical to those of the corresponding softkeys of the basic unit.</p> <p><i>CENTER</i> Enables the center frequency of the analyzer to be set.</p> <p><i>CF STEP</i> Selects automatic (CF STEP = AUTO) or manual (CF STEP = MAN) step size selection.</p> <p>In the automatic mode, the step size is varied by 1/1000 of the selected center frequency. In the manual mode, the step size is varied via the CF STEP SIZE setting parameter.</p> <p><i>CF STEP SIZE</i> Enables selection of the step size for center frequency setting in the manual mode by means of the rotary knob or the navigation keys.</p> <p><i>FREQUENCY OFFSET</i> Adds a numerical offset to the values plotted along the frequency axis without changing the currently selected center frequency. Frequency offsets between -100 GHz and +100 GHz can be added; the default setting is 0 Hz.</p>
---	--	---

Span - SPAN Key

The SPAN key has no function with respect to the R&S FSQ-K70/FSMR-B73/FSU-B73 option.

Level Settings - AMPT Key

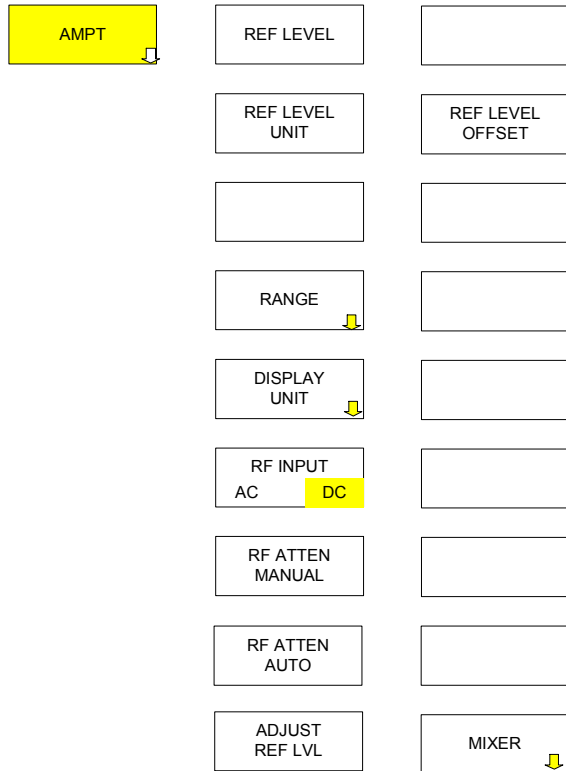

The *AMPT* key opens a menu for making the settings for the reference level, for control of the RF attenuation at the instrument input, and for selecting the level display unit.

REF LEVEL Enables input of the reference level. If the reference level is entered manually, care should be taken to avoid analyzer overdrive during IQ data input.

REF LEVEL UNIT Selects the unit for the reference level.

RANGE Opens another menu for setting the display scaling. A softkey of identical name and function is also included in the *OPTIONS* menu of the R&S FSQ-K70/FSMR-B73/FSU-B73 option; see section "[Setting of Span - RANGE Softkey](#)".

DISPLAY UNIT Opens a submenu for selecting the unit for the displayed trace (dBm, %, rad, deg).

RF INPUT AC / DC Selects AC or DC coupling for the RF input.

RF ATTEN MANUAL Enables manual setting of RF attenuation independently of the reference level.

RF ATTEN AUTO Activates automatic setting of the RF attenuation to an optimal value as a function of the selected reference level.

ADJUST REF LVL Determines the applied signal level by means of a pre-measurement and sets the reference level of the instrument to an optimal value. A softkey of identical name and function is also included in the *OPTIONS* menu of the R&S FSQ-K70/FSMR-B73/FSU-B73 option.

REF LEVEL OFFSET Enables the input of a numerical level offset for the displayed trace.

MIXER Opens a submenu for setting the mixer level.

Selection of Units for Display - DISPLAY UNIT Key



The *DISPLAY UNIT* softkey opens a menu for selecting the units for the values displayed as well as linear or logarithmic display of results.



Y UNIT LOG DB Selects logarithmic scaling for the display of results and the Y axis.



Y UNIT LIN Selects linear scaling for the display of results and the Y axis.



Y UNIT RAD Selects radians (RAD) for the display of the phase or phase error of the measured signal.

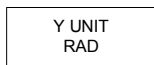

Y UNIT DEG Selects angular degrees (DEG) for the display of the phase or phase error of the measured signal.



X UNIT TIME Selects seconds (SEC) for the display of time.



X UNIT SYMBOL Selects symbols (SYM) for the display of time.

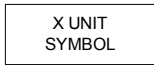
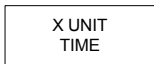

Setting of Bandwidth for Analog IF Filter - BW Key

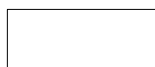

The *BW* key opens a submenu for setting the bandwidth of the analog IF filters.

RES BW MANUAL Enables manual selection of the filters with nominal bandwidths of 300 kHz, 500 kHz, 1/3/5/10/20/50 MHz (RBW 20 and 50 MHz for R&S FSMR and R&S FSQ only).

- For bandwidths ≥ 3 MHz, the amplitude and phase response are corrected up to typically 2/3 of the nominal frequency; within this bandwidth, filter effects on demodulation results can be ignored. The maximum achievable corrected bandwidth is
 for R&S FSQ/FSMR 28 MHz (50 MHz RBW filter),
 for R&S FSU 7 MHz (10 MHz RBW filter).

For more information and details regarding the role these filters play in vector signal analysis, refer to chapter "**Getting Started/Analog RBW Prefilters**" of this manual.

- For bandwidths < 3 MHz, amplitude and phase response correction is not performed. Only max. 10 % of the nominal bandwidth of the filters should be used to avoid the risk of increased measurement errors.
- Manual filter selection is recommended if difficult reception conditions prevail, e.g.:
 - strong signals on adjacent channels,
 - interference through mixture products and other signals.

RES BW AUTO Activates the automatic selection of a resolution bandwidth that matches the current instrument settings. Amplitude and phase response are corrected in this case.

Sweep Settings - Sweep Key



CONTINUOUS SWEEP

SINGLE SWEEP

DEMOD NEXT RIGHT

DEMOD RESTART

SWEEP COUNT

CAPTURE AUTO OFF

MULTI ON OFF

The *SWEEP* key opens a submenu where the following settings can be made:

CONTINUOUS SWEEP
SINGLE SWEEP
SWEEP COUNT

CONTINUOUS SWEEP

Consecutive test cycles are performed with the current instrument settings. During each cycle, data collection, signal demodulation, and the display of results take place anew.

SINGLE SWEEP

A complete test cycle is performed. To start a new cycle, the softkey has to be actuated again.

If a parameter is changed after a test cycle, no new data will be collected, but the **old RECORD BUFFER data** will be re-demodulated **with the modified parameterization** and the result re-displayed.

If a parameter change **directly affects data collection** such that no meaningful result will be displayed, a warning message is output; possible parameter changes include:

- external trigger
- symbol rate
- points/symbol
- record buffer
- digital standard

The changed parameter is not taken into account until the next test cycle (next single sweep).

MULTI ON/OFF

switches **multiple evaluation mode** on and off. If MULTI ON is selected, a new capture is performed once the end of the record buffer has been reached. Otherwise, the message '**End of Buffer**' will be output.

CAPTURE AUTO / OFF

starts automatic data capture if the end of the record buffer has been reached. If *CAPTURE OFF* is selected, data capture will not be started. When the end of the record buffer is reached, the message '**End of Buffer**' will be output. This softkey is available only in MULTI mode in conjunction with SINGLE SWEEP.

DEMOM NEXT RIGHT

DEMOM RESTART

DEMOM @ ZOOM START

control demodulation in multiple evaluation mode. These softkeys are available only in MULTI mode in conjunction with SINGLE SWEEP. You can find a detailed description of this control (also for demodulation of burst signals) in the section "[Multiple Evaluation of a Captured Data Record \(MULTI\)](#)".

SWEEP COUNT Enables input of the number of sweeps the analyzer will perform after the start of SINGLE SWEEP. If Trace Average, Min or Max Hold is active, this input at the same time defines the number of averages to be taken (see description of *TRACE* menu).

MEAS Key

The MEAS key opens the main menu of option R&S FSQ-K70/FSMR-B73/FSU-B73 (see HOME VSA key).

Trigger Settings - TRIGGER Key

<div style="border: 1px solid black; background-color: yellow; padding: 2px; margin-bottom: 5px;">TRIGGER</div> <div style="border: 1px solid black; padding: 2px; margin-bottom: 5px;">FREE RUN</div> <div style="border: 1px solid black; padding: 2px; margin-bottom: 5px;">EXTERN</div> <div style="border: 1px solid black; padding: 2px; margin-bottom: 5px;">IF POWER</div> <div style="border: 1px solid black; padding: 2px; margin-bottom: 5px;">I/Q LEVEL</div> <div style="border: 1px solid black; padding: 2px; margin-bottom: 5px;">TRIGGER OFFSET</div> <div style="border: 1px solid black; padding: 2px; margin-bottom: 5px;">POLARITY POS NEG</div> <div style="border: 1px solid black; padding: 2px; margin-bottom: 5px;">MEAS ONLY ON BURST</div> <div style="border: 1px solid black; padding: 2px;">MEAS ONLY ON PATT</div>	<p>The <i>TRIGGER</i> key opens a menu for selecting a trigger source for the R&S FSQ-K70/FSMR-B73/FSU-B73 option.</p> <p><i>FREE RUN</i> Activates a free-running test sequence, i.e. measurements are not started by a trigger, but a measurement is immediately started after the previous one has been completed. <i>FREE RUN</i> is the default setting of the R&S FSQ-K70/FSMR-B73/FSU-B73 option.</p> <p><i>EXTERN</i> Activates an external TTL trigger signal, which is applied to the EXT TRIGGER /GATE input on the rear of the instrument. The external trigger level can be adjusted in the range from 0.5V to 3.5V. The polarity of the trigger signal can be selected with <i>POLARITY</i>. IEC/IEEE-bus command TRIG:LEV 2.1</p> <p><i>TRIGGER OFFSET</i> Used to set a time interval between the trigger event and the start of data collection: If a positive trigger offset is entered, the start of data collection will be delayed relative to the trigger signal. If a negative trigger offset is entered, the start of data collection will be advanced relative to the trigger signal.</p> <p><i>POLARITY</i> Selects the polarity of the trigger edge; i.e. data will be collected on the positive (= POS) or the negative (= NEG) edge of the trigger signal.</p> <p><i>MEAS ONLY ON PATT</i> <i>MEAS ONLY ON BURST</i> Data collection and demodulation are performed in either case, whereas results are displayed only if the demodulated signal contains either a synchronization pattern or constitutes a burst signal. A softkey of identical name and function is included in the <i>BURST & PATTERN</i> menu (<i>BURST & PATTERN</i> softkey) of the R&S FSQ-K70/FSMR-B73/FSU-B73 option.</p>
--	--

Trace Functions - TRACE Key

TRACE	SELECT TRACE	MIN HOLD	The TRACE key opens a menu for setting the trace functions.
	CLEAR / WRITE	AVG MODE (LOG)	SELECT TRACE selects the trace of the active measurement screen.
	MAX HOLD	FILE EXPORT	The trace display mode can be selected as follows:
	AVERAGE	FILE IMPORT	CLEAR WRITE Overwrite mode; the old trace is deleted after each measurement and overwritten by the new trace.
	VIEW	DATA TRACE	VIEW BLANK The current trace is frozen. The selected trace is blanked.
	BLANK	DATA RAW	Weighting of the complete trace is selected as follows:
	SWEEP COUNT	HEADER ON OFF	AVERAGE The average value is determined.
	RMS	DECIM SEP	MAX HOLD The maximum value is determined.
			MIN HOLD The minimum value is determined.
			Export of all active traces is selected as follows:
			FILE EXPORT All active traces are stored
			DATA RAW The data type RAW DATA is selected. The formats ASCII and WAVEFORM are supported.
			Note: Files saved with format WAVEFORM are loadable by R&S SMU signal generator.
			HEADER A file header is created or not
			DECIM SEP The decimal separator is selected.
			FILE IMPORT Imports the I/Q RAW data previously stored with FILE EXPORT (DATA RAW, format binary).

Trace averaging

Sweep count setting	Prior to reaching selected sweep count (n < N)	After reaching selected sweep count (n >= N)
SWEEP COUNT = 0	-	$TRACE_n = \frac{9}{10} * TRACE_{n-1} + \frac{1}{10} * measurement_n$
SWEEP COUNT = 1	-	$TRACE_n = measurement_n$
SWEEP COUNT > 1	$TRACE_n = \frac{1}{n} \left[\sum_{i=1}^{n-1} (TRACE_i) + measurement_n \right]$	$TRACE_n = \frac{N-1}{N} * TRACE_{n-1} + \frac{1}{N} * measurement_n$

Invoking the AVERAGE function with IQ displays (e.g. IQ Constellation, EYE) does not result in the averaging of traces but rather displays the current measurement without deleting the displayed measurements (overwrite mode). This setting can be used to check the dispersion of points in the constellation diagram over many sweeps. The hard copy function prints only the last sweep.

Trace Export

The file consists of the containing important scaling parameters and a data section containing the trace data. The data of the file header consist of three columns, each separated by a semicolon: parameter name; numeric value; basic unit

The data section starts with the keyword " Trace <n> " (<n> = number of stored trace), followed by the measured data in one or several columns (depending on measurement) which are also separated by a semicolon.

The number of measurement values and therefore the size of the output file is determined:

- by parameters RESULT LENGTH, POINT/SYMBOL for trace data
- by parameter RECORD LENGTH for raw data

In particular, storing the I/Q raw data with up to 16 millions samples can take several minutes.

The format of the stored data can be read in from spreadsheet calculation programs, eg MS-Excel. It is necessary to define ';' as a separator.



The *FILE EXPORT* softkey stores all active traces in a file with ASCII format.

IEC/IEEE-bus command `FORM ASC`
`MMEM:STOR:TRAC`

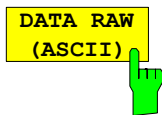

The *DATA RAW* softkey selects the output of the measured raw I/Q data or the trace data.

IEC/IEEE-bus command `FORM:DEXP:MODE RAW`

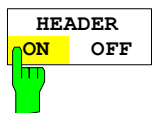

The *HEADER ON/OFF* softkey defines whether important instrument settings should be stored at the beginning of the file. The instrument model, the version and the date are always transferred.

IEC/IEEE-bus command `FORM:DEXP:HEAD OFF`



The *DECIM SEP* softkey softkey selects the decimal separator for the ASCII file. The choice is '.' (decimal point) or ',' (comma). The decimal separator used in various language versions of evaluation programs (e.g. MS-Excel) can be selected so that the packages are supported.

IEC/IEEE-bus command `FORM:DEXP:DSEP POIN`

Example:

File header	Content of file	Description
	Type;FSQ; Version;3.45; Date;02.Apr 2004; Mode;VSA;DB1.00	Instrument model Firmware version Date record storage date Instrument operating mode
	Digital Standard;GSM_NB; Demodulator;DMSK;	Digital standard Demodulation
	Center Freq;100000000.00000;Hz Freq Offset;0.000000;Hz	Center frequency Frequency offset
	Ref. Level;-20.000000;dBm Level Offset;0.000000;dB RF Att;5.000000;dB EI Att;0;dB	Reference level Level offset Input attenuation Input attenuation (with option FSU-B25 only)
	Symbol Rate;270833.000000;Hz Transmit Filter;GAUSS; Receive Filter;NONE; Measurement Filter;NONE; Raw Data Filter;ON; Alpha BT;0.300000; Signal;RF Input; Result Length;160; Record Length;1500; Points per symbol;4;	Symbol rate Filter settings Signal source Result length Record buffer length Points per symbol
	x Axis Start;-9.000000;symbols x Axis Stop;150.750000;symbols	Scaling of x-axis
	y per div;1.000000;deg Ref Value y-Axis;0.000000;deg Ref Value Position;50.000000;%	Scaling of y-axis
	Sweep Count;0;	Number of sweeps set

Data part of the file	Trace;1; Screen;A; Meas Result;Error; Meas Signal;Phase; Demodulator;DMSK;	Trace Screen A Measurement: Error Signal, Phase Error
Trace 1 / Screen A	ResultMode;Trace; x Unit;symbols; y Unit;deg; Trace Mode;CLR/WRITE;	Trace mode Unit of x and y values
	Values;640; 1.834240 1.662848 -0.127578 -0.889226	Display mode of trace: CLR/WRITE, AVERAGE, MAXHOLD, MINHOLD Number of measurement points Measured values:: <real>, <imag> <imag> being available only with Real/Imag, Polar- and Constellation diagrams.
Data part of the file	Trace;1; Screen;B; Meas Result;Meas; Meas Signal;Magnitude; Demodulator;DMSK;	Trace Screen B Measurement: Meas Signal, Magnitude
Trace 1 / Screen B	ResultMode;Trace; x Unit;symbols; y Unit;deg; Trace Mode;CLR/WRITE; Values;640;	
	0.681856 0.680534 0.682217	

Trace-Import

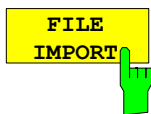

Softkey *FILE IMPORT* imports I/Q RAW data previously stored with FILE EXPORT (DATA RAW, format binary).

This softkey is only available, if DATA RAW is selected with format BINARY. The import of the I/Q RAW data requires the MULTI mode to be active. This mode is automatically switched on with start of the load process. For more details refer to HOME VSA → MEAS RESULT → CAPTURE BUFFER → ZOOM → MULTI.

The VSA base settings (<file_name>.VAV) are loaded first. The I/Q RAW data <file_name>.BIN are loaded in a second step.

IEC/IEEE-bus command :MMEM:LOAD:TRAC 1, 'D:\rawdat'

Limit Lines Settings - LINES Key

The LINES key has no function with respect to the R&S FSQ-K70/FSMR-B73/FSU-B73 option.

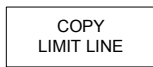
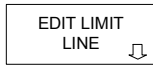
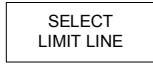

Limit lines are used on the display to mark level characteristics or spectral distributions whose upper and lower limits must not be exceeded. For example, upper and lower limit lines can be set for the tolerance range of a GSM burst, and these limit lines are automatically checked to determine if they have been exceeded.

LINES are not available for the following result and error displays:

- Modulation errors/symbols
- IQ displays (vector and constellation diagram)
- Real/Imag
- Statistic

Softkey operation is identical to the limit lines of the spectrum analyzer.

Screen Configuration - DISP Key

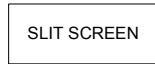

The *DISPLAY* key opens a menu for screen configuration. The functions of the softkeys of the *DISPLAY* menu are largely identical to those of the corresponding softkeys of the basic unit.

FULL SCREEN Selects full-screen display of results, i.e. in a single diagram.

SPLIT SCREEN Selects split-screen display of results, i.e. in two diagrams.

IEC/IEEE bus commands: `DISP:FORM SING`
`DISP:WIND<1|2>:SEL`

Unlike the spectrum mode of the basic unit, the two screens are **NOT decoupled** from each other in the split screen mode. The traces shown in the two measurement screens are coupled to common IQ data across the *RESULT LENGTH* (width of display), and *FIT TRACE* (positioning of events on the display) likewise acts on both windows.

Exceptions to this rule are the *MAGNITUDE CAPTURE BUFFER* setting and the *MODULATION ERROR* measurement.

MAG CAP BUFFER automatically adapts the width of the active screen to match the complete *RECORD BUFFER*.

Numerical evaluations of the *MODULATION ERROR* screen are specific to the useful part of a burst or to the *EVAL LINES*.

CONFIG DISPLAY Opens a submenu for setting the colours, the brightness and the colour saturation of the display.

For detailed information refer to the manual of the basic unit.

File Management - FILE Key

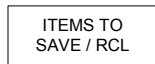

The *FILE* key opens a menu for saving and restoring complete instrument settings plus, for the R&S FSQ-K70/FSMR-B73/FSU-B73 option, standard definitions, user filters and synchronization patterns.

SAVE Saves the current instrument settings.
RECALL Restores the selected instrument setting.

Note:
*The RECALL function should be used with great care as far as the R&S FSQ-K70/FSMR-B73/FSU-B73 settings are concerned: Currently selected **standard definitions, user filters and synchronization patterns** will be **overwritten** if a saved version is recalled.
 Any current **modifications** made will be lost when the saved version is restored with RECALL.*

EDIT COMMENT opens an input window for adding a comment to the data set to be saved.
ITEMS TO SAVE/ RCL selects the settings to be saved.
DATA SET LIST opens a management table for the saved data sets.
STARTUP RECALL defines the data set to be automatically loaded on startup of the instrument.
FILE MANAGER opens a submenu for storage media and file management.

A detailed description of the above softkeys can be found in the manual of the basic unit.

Marker Settings - MARKER Key



MARKER 1	MKR -> TRACE
MARKER 2	
MARKER 3	
MARKER 4	
MARKER NORM DELTA	
ALL MARKER OFF	

The *MARKER* key opens a menu for marker settings.

Markers are used for marking points of interest on a trace and for defined reading of a trace.

In contrast to the basic unit, the R&S FSQ-K70/FSMR-B73/FSU-B73 option does not allow screen sections to be defined by means of markers.

The measurement screen is in this case exclusively defined by the *RESULT LENGTH* and *FIT TRACE* settings.

The values measured for the active marker are output in the marker field in the upper right screen area.

MARKERS 1 TO 4 Selects the active marker.

MARKER NORM/ DELTA Switches between marker function and delta marker function.

ALL MARKER OFF Switches off all markers on the screen.

MKR -> TRACE Sets the active marker to a new trace. The new trace must be visible on the active screen.

Marker Settings (Marker to) - MKR -> Key



SELECT
MARKER

The *MKR ->* key opens a menu for finding the maximum and minimum values on a trace.

MAX PEAK

In the case of the R&S FSQ-K70/FSMR-B73/FSU-B73 option, the active marker does NOT cause a change of the instrument setting.

MIN PEAK

SELECT MARKER Selects a desired marker; if that marker was switched off, it will be switched on by this function.

MAX |PEAK|

MAX PEAK Places the marker on the maximum value.

MIN PEAK

MIN PEAK Places the marker on the minimum value.

MAX |PEAK|

MAX |PEAK| Places the marker on the maximum absolute value.

MKR -> TRACE

MKR -> TRACE Places the active marker on a selectable active trace.

MKR ->
TRACE

Marker Functions - MKR FCTN Key



COMP PT
(1 dB)

The *MKR FCT* softkey opens a menu with special markers and calculation functions.

⋮

COMP PT
(1 dB)

The *COMP PT* softkey opens a menu for entering the compression factor needed and displays it within the measurement window.

The default setting is 1 dB.

The compression point of the DUT is determined using two markers in the AM/AM diagram. The markers are horizontally spaced at 10 dB, and both markers are moved along the trace until the vertical spacing is 1 dB. The position of marker {C} indicates the compression point of the DUT.

The compression point and other parameters are displayed in the AM/PM measurement diagram. Scaling of the AM/PM diagram is relative to the unit circle of the constellation diagram. The power of the marker is recalculated to the input power and displayed in dBm.

In addition, the mean power and the crest factor of the reference and measurement signals as well as the difference between the results are calculated and displayed in the lower diagram (see figure).

These values indicate the compression of the mean power or the reduction of the crest factor for the current modulation of the DUT. If either of the two compression markers exceeds the borders of the diagram, a compression point will not be calculated and output.

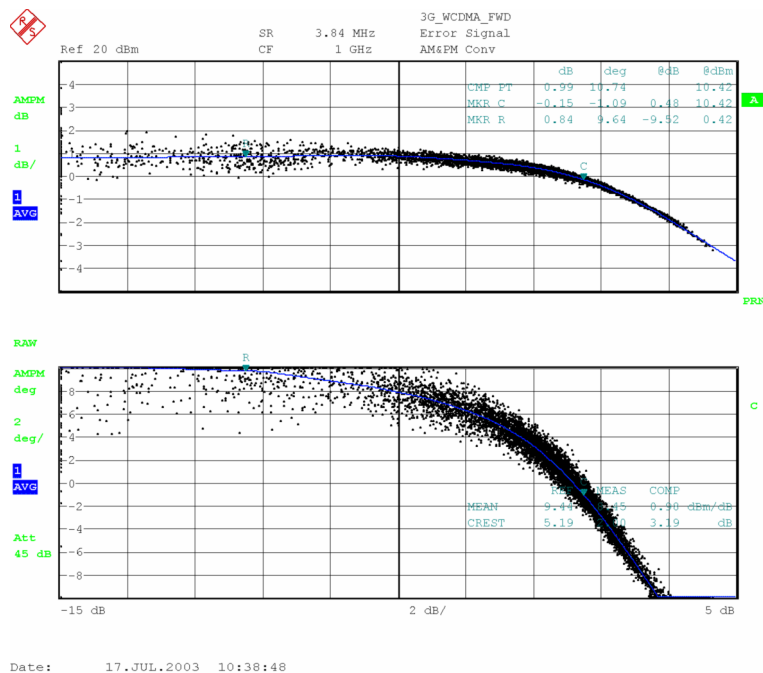
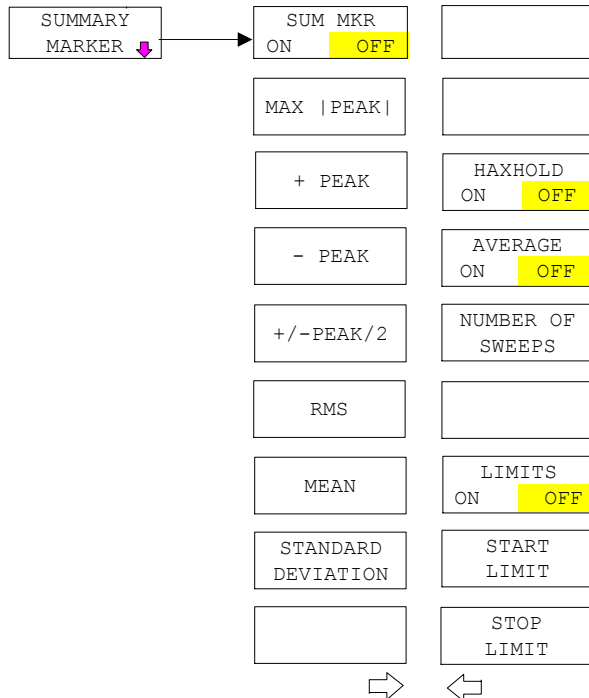

Fig. 240 AM/AM and AM/PM diagram with calculation of the compression point

IEEE/IEC bus commands CALC:MARK:FUN:CPO:STAT ON
 CALC:MARK:FUN:CPO:VAL <num>
 CALC:MARK:FUN:CPO:PHD?
 CALC:MARK:FUN:CPO:POW?

Menu MKR FCTN - SUMMARY MARKER



The summary marker functions allows several evaluations of a complete trace data set. These evaluation functions can be activated in parallel. The result is displayed in the marker info field.

The measured values are updated after each sweep or averaged over a user-defined number of sweeps (*AVERAGE ON/OFF* and *NUMBER OF SWEEPS*) in order to determine e.g. the mean power over several bursts. For determination of the peak value (*MAX HOLD ON*) the maximum value from several sweeps is displayed.

Example:

Marker info field for: *MEAN* selected, *AVERAGE ON* and *MAX HOLD ON*.

MEAN HOLD	12.03 deg
MEAN AV	11.75 deg

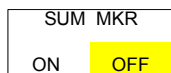

The *SUM MKR ON/OFF* softkey switches summary marker on and off. When entering the submenu it is *ON* since the summary marker measurement is already switched on with the *SUMMARY MARKER* softkey in the main menu.

Note: *The measurement is performed on the trace on which marker 1 is placed. To evaluate another trace, marker 1 should be set on another trace using the SELECT TRACE softkey in menu MKR.*

```
IEC/IEEE-bus command: CALC:MARK:FUNC:SUMM:MAX ON
                        CALC:MARK:FUNC:SUMM:MAX:RES?
                        CALC:MARK:FUNC:SUMM:PPE ON
                        CALC:MARK:FUNC:SUMM:PPE:RES?
                        CALC:MARK:FUNC:SUMM:MPE ON
                        CALC:MARK:FUNC:SUMM:MPE:RES?
                        CALC:MARK:FUNC:SUMM:MIDD ON
                        CALC:MARK:FUNC:SUMM:MIDD:RES?
                        CALC:MARK:FUNC:SUMM:RMS ON
                        CALC:MARK:FUNC:SUMM:RMS:RES?
                        CALC:MARK:FUNC:SUMM:MEAN ON
                        CALC:MARK:FUNC:SUMM:MEAN:RES?
                        CALC:MARK:FUNC:SUMM:SDEV ON
                        CALC:MARK:FUNC:SUMM:SDEV:RES?
```

MAX | PEAK |

The *MAX* |*PEAK*| softkey switches on the calculation of the absolute peak value from the points of the displayed trace or a segment thereof.

For the maximum absolute peak, the largest absolute peak value obtained since the activation of *MAX HOLD ON* is displayed.

With *AVERAGE ON*, the absolute peak values of a trace are averaged over several sweeps and displayed.

The number of sweeps over which the average or the maximum value is calculated is set with the *NUMBER OF SWEEPS* softkey.

IEC/IEEE-bus command: `CALC:MARK:FUNC:SUMM:MAX ON`
 `CALC:MARK:FUNC:SUMM:MAX:RES?`

+ PEAK

The *PEAK* softkey switches on the calculation of the positive peak value from the points of the displayed trace or a segment thereof.

For the positive peak, the largest positive peak value obtained since the activation of *MAX HOLD ON* is displayed.

With *AVERAGE ON*, the peak values of a trace are averaged over several sweeps and displayed.

The number of sweeps over which the average or the maximum value is calculated is set with the *NUMBER OF SWEEPS* softkey.

IEC/IEEE-bus command: `CALC:MARK:FUNC:SUMM:PPE ON`
 `CALC:MARK:FUNC:SUMM:PPE:RES?`

- PEAK

The *PEAK* softkey switches on the calculation of the negative peak value from the points of the displayed trace or a segment thereof.

For the negative peak, the largest negative peak value obtained since the activation of *MAX HOLD ON* is displayed.

With *AVERAGE ON*, the peak values of a trace are averaged over several sweeps and displayed.

The number of sweeps over which the average or the maximum value is calculated is set with the *NUMBER OF SWEEPS* softkey.

IEC/IEEE-bus command: `CALC:MARK:FUNC:SUMM:MPE ON`
 `CALC:MARK:FUNC:SUMM:MPE:RES?`

+/- PEAK/2

The *PEAK* softkey switches on the calculation of the mean peak value from the points of the displayed trace or a segment thereof.

For the maximum mean peak, the largest mean peak value obtained since the activation of *MAX HOLD ON* is displayed.

With *AVERAGE ON*, the peak values of a trace are averaged over several sweeps and displayed.

The number of sweeps over which the average or the maximum value is calculated is set with the *NUMBER OF SWEEPS* softkey.

IEC/IEEE-bus command: `CALC:MARK:FUNC:SUMM:MIDD ON`
 `CALC:MARK:FUNC:SUMM:MIDD:RES?`

RMS

The *RMS* softkey switches on the calculation of the rms value from the points of the displayed trace or a segment of it.

For the maximum peak, the largest rms value obtained since the activation of *MAX HOLD ON* is displayed.

With *AVERAGE ON*, the rms values of a trace are averaged over several sweeps and displayed.

The number of sweeps over which the average or the maximum value is calculated is set with the *NUMBER OF SWEEPS* softkey.

IEC/IEEE-bus command: `CALC:MARK:FUNC:SUMM:RMS ON`
`CALC:MARK:FUNC:SUMM:RMS:RES?`

MEAN

The *MEAN* softkey switches on the calculation of the mean value from the points of the displayed trace or a segment of it. The linear mean value of the equivalent voltages is calculated.

For the maximum peak, the largest mean value obtained since the activation of *MAX HOLD ON* is displayed.

With *AVERAGE ON*, the mean values of a trace are averaged over several sweeps and displayed.

The number of sweeps over which the average or the maximum value is calculated is set with the *NUMBER OF SWEEPS* softkey.

IEC/IEEE-bus command: `CALC:MARK:FUNC:SUMM:MEAN ON`
`CALC:MARK:FUNC:SUMM:MEAN:RES?`

STANDARD
DEVIATION

The *STANDARD DEVIATION* softkey switches on the calculation of the standard deviation of trace points from the mean value and outputs them as measured value. The measurement of the mean power is automatically switched on at the same time.

For the maximum peak, the largest standard deviation obtained since the activation of *MAX HOLD ON* is displayed.

With *AVERAGE ON*, the standard deviations of a trace are averaged over several sweeps and displayed.

The number of sweeps over which the average or the maximum value is calculated is set with the *NUMBER OF SWEEPS* softkey.

IEC/IEEE-bus command: `CALC:MARK:FUNC:SUMM:SDEV ON`
`CALC:MARK:FUNC:SUMM:SDEV:RES?`

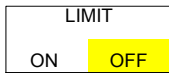

The *LIMIT ON/OFF* softkey selects the limited (*ON*) or non-limited (*OFF*) evaluation range.

The evaluation range is defined by the *START LIMIT* and *STOP LIMIT* softkeys. If *LIMIT = ON*, signals are only searched between the two lines.

If only one limit line is switched on, time line 1 is the lower limit and the upper limit corresponds to the end of grid. If time line 2 is also switched on, it defines the upper limit.

In addition, the default position is limited to the eval range, defined by the position of the eval lines 1 and 2. This is useful for bursted signals, where the useful part of the burst is defined by the eval line position.

If no limit line is switched on, the evaluation range is not limited.

The default setting is *LIMIT = OFF*.

IEC/IEEE-bus command: `CALC:MARK:X:SLIM OFF`



The *START LIMIT* softkey activates the entry of the lower limit of the evaluation range.

IEC/IEEE-bus command: `CALC:MARK:X:SLIM:LEFT <value>`



The *STOP LIMIT* softkey activates the entry of the upper limit of the evaluation range.

IEC/IEEE-bus command: `CALC:MARK:X:SLIM:RIGH <value>`

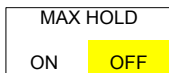

The *MAX HOLD ON/OFF* softkey switches the display of the maximum peak obtained from measurements at successive sweeps on and off.

The displayed maximum peak is only updated at the end of a sweep if a higher value has occurred.

The maximum value can be reset by switching the *MAX HOLD ON / OFF* softkey off and on again.

IEC/IEEE-bus command: `CALC:MARK:FUNC:SUMM:PHOL ON`
`CALC:MARK:FUNC:SUMM:MAX:PHOL:RES?`
`CALC:MARK:FUNC:SUMM:PPE:PHOL:RES?`
`CALC:MARK:FUNC:SUMM:MPE:PHOL:RES?`
`CALC:MARK:FUNC:SUMM:MIDD:PHOL:RES?`
`CALC:MARK:FUNC:SUMM:RMS:PHOL:RES?`
`CALC:MARK:FUNC:SUMM:MEAN:PHOL:RES?`
`CALC:MARK:FUNC:SUMM:SDEV:PHOL:RES?`

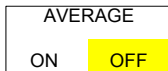

The *AVERAGE ON/OFF* softkey switches averaging over successive sweep measurements on and off.

The measured values can be reset by switching the *AVERAGE ON / OFF* softkey off and on again.

IEC/IEEE-bus command: `CALC:MARK:FUNC:SUMM:AVER ON`
`CALC:MARK:FUNC:SUMM:MAX:AVER:RES?`
`CALC:MARK:FUNC:SUMM:PPE:AVER:RES?`
`CALC:MARK:FUNC:SUMM:MPE:AVER:RES?`
`CALC:MARK:FUNC:SUMM:RMS:AVER:RES?`
`CALC:MARK:FUNC:SUMM:MIDD:AVER:RES?`
`CALC:MARK:FUNC:SUMM:MEAN:AVER:RES?`
`CALC:MARK:FUNC:SUMM:SDEV:AVER:RES?`

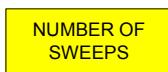

The *NUMBER OF SWEEPS* softkey activates the entry of the number of sweeps for maximum or average value calculation.

SINGLE SWEEP mode

The R&S FSQ/FSMR/FSU performs measurements until the selected number of sweeps is reached and stops then.

CONTINUOUS SWEEP mode

Averaging is carried out until the selected number of sweeps is reached. After that, averaging is performed in continuous mode and is then continued as running averaging. Calculation of the maximum peak (*MAX HOLD*) is performed continuously irrespective of the selected number of sweeps.

The valid range values is 0 to 32767.

Depending on the specified number of sweeps, averaging is carried out according to the following rules:

NUMBER OF SWEEPS = 0 Continuous averaging is carried out over 10 measured values.
NUMBER OF SWEEPS = 1 No averaging is carried out.
NUMBER OF SWEEPS > 1 Averaging is carried out over the set number of measured values.

Note: *This setting is equivalent to the setting of the sweep count in the TRACE menu.*

IEC/IEEE-bus command: `SWE:COUN <value>`

Troubleshooting

Based on measurement examples, this chapter provides information on how to identify possible sources of error or incorrect instrument settings in the event that measurement results appear unlikely.

Different Symbol Rate Setting in Transmitter and Analyzer

Even very slight discrepancies between the transmitter and the receiver symbol rate will produce an increase of the displayed EVM. This manifests itself by a V-shaped characteristic of the EVM as a function of time.

The following two diagrams show the EVM when the symbol rate setting is identical (Fig. 241) and with a deviation of only 0.005% of the symbol rate (Fig. 242). The effect is explained by the decision points of the measurement signal "drifting away" over the demodulation range: optimum matching in the displayed measurement is achieved only at the center of the demodulation range.

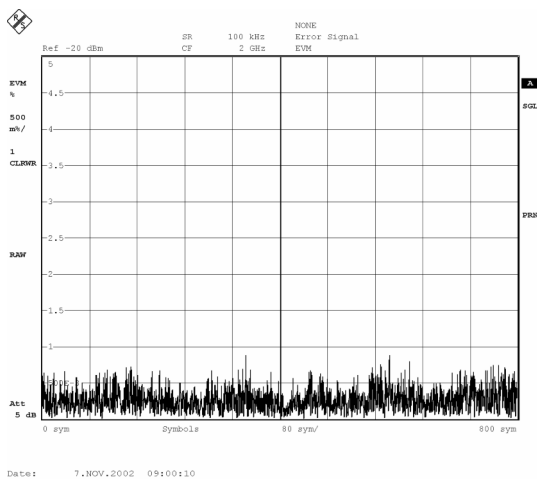

Fig. 241 Displayed EVM with correct setting of the symbol rate

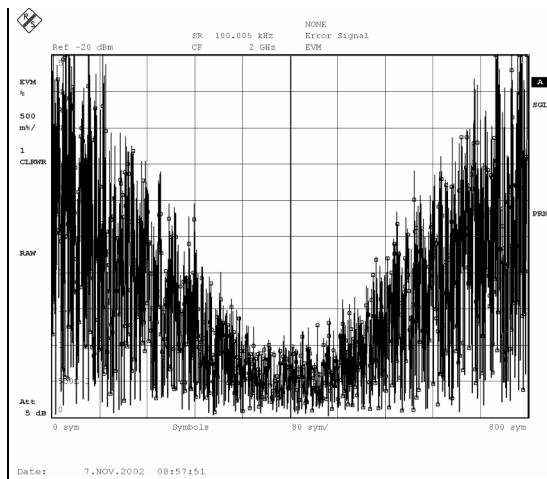

Fig. 242 Displayed EVM with incorrect setting of the symbol rate

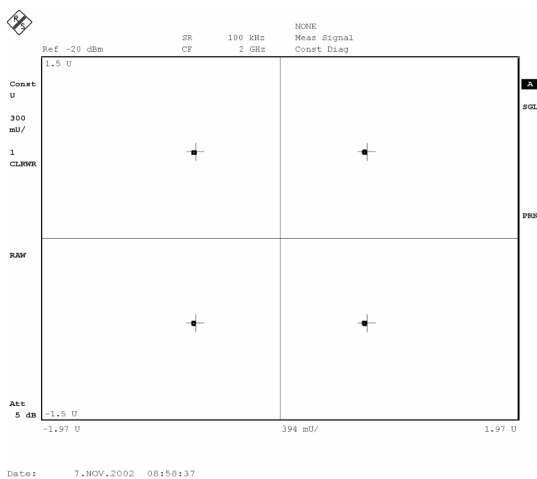

Fig. 243 Constellation diagram with correct setting of the symbol rate

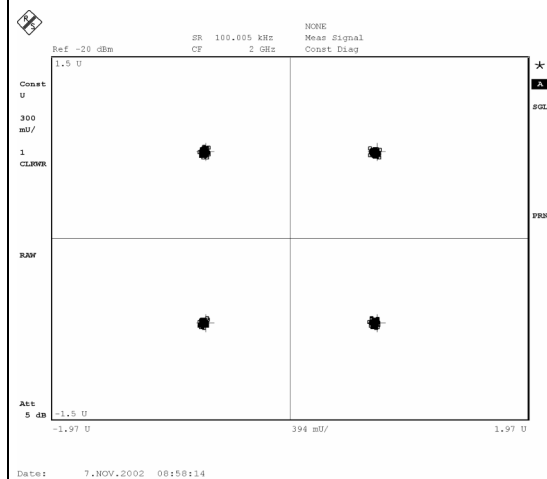

Fig. 244 Constellation diagram with incorrect setting of the symbol rate

Different Filter Settings in Transmitter and Analyzer

The type of receive filter (e.g. raised cosine) and the ALFA/BT bandwidth parameter settings in the analyzer must exactly agree with the settings in the transmitter. In this case, too, even very slight discrepancies have a strong impact on the displayed errors.

In the following example, a root raised cosine was used as the transmit and receive filter, the bandwidth factor ALFA/BT = 0.22 was set in the transmitter, and ALFA/BT = 0.25 was set in the analyzer.

Although the illustrated effect causes only a slight increase in the EVM at the decision points (Fig. 245 and Fig. 246, bottom), the spectral analysis of the error signal already shows a noticeable increase at the edge of the spectrum, while the spectrum is nearly flat at the correct filter setting (Fig. 247 and Fig. 248).

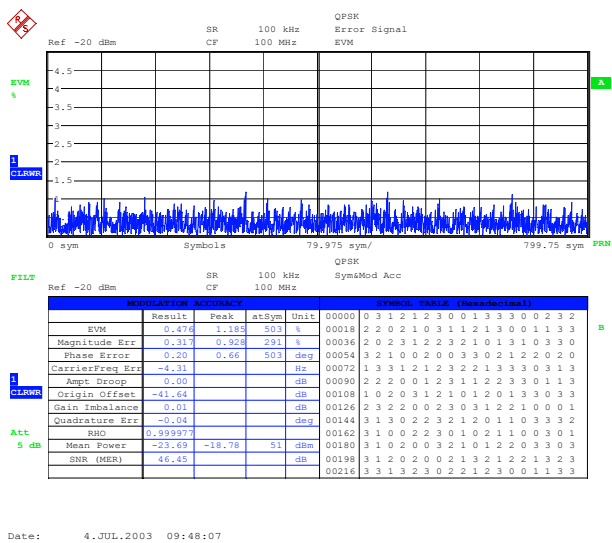

Date: 4.JUL.2003 09:48:07

Fig. 245 Displayed EVM with correct filter settings (decision points only)

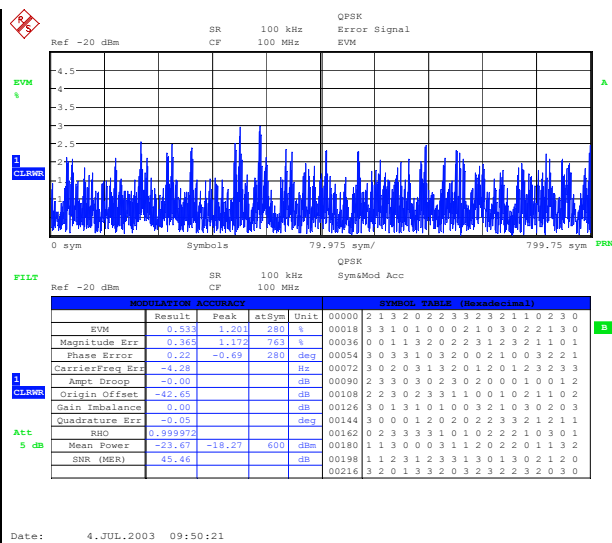

Date: 4.JUL.2003 09:50:21

Fig. 246 Displayed EVM with different filter settings (decision points only)

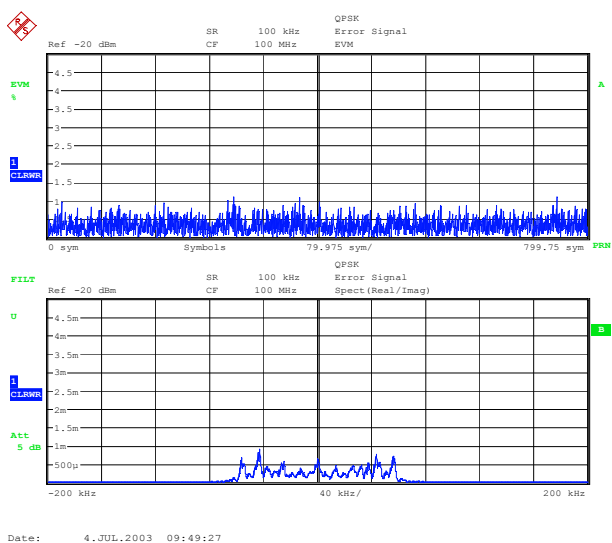

Date: 4.JUL.2003 09:49:27

Fig. 247 Displayed error spectrum with correct filter settings

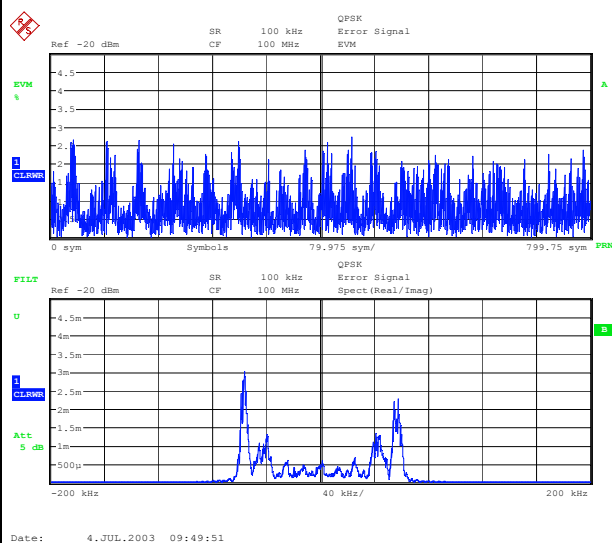

Date: 4.JUL.2003 09:49:51

Fig. 248 Displayed error spectrum with different filter settings

Incorrect Modulation of Analyzer

In the event of a poor signal-to-noise ratio, for example in the presence of a weak input signal, the measured modulation error will considerably increase. The diagrams below are an example of this, showing the measured error for a strongly reduced input signal level (approx. 60 dB below reference signal level). The statistical distribution of the Magnitude Error at the decision points provides information on the noise structure of the interfering signal.

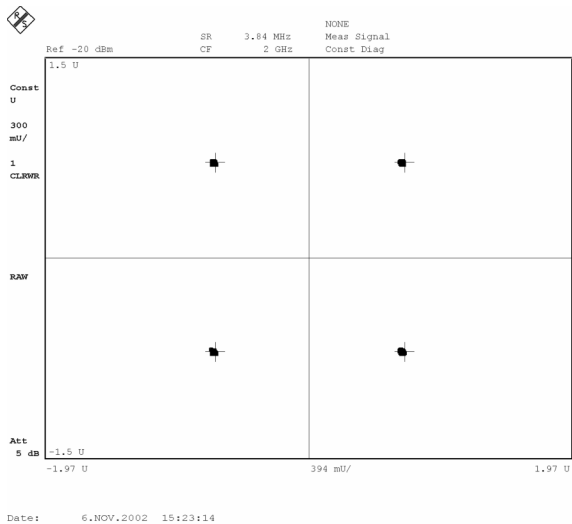

Fig. 249 Constellation diagram with correct modulation

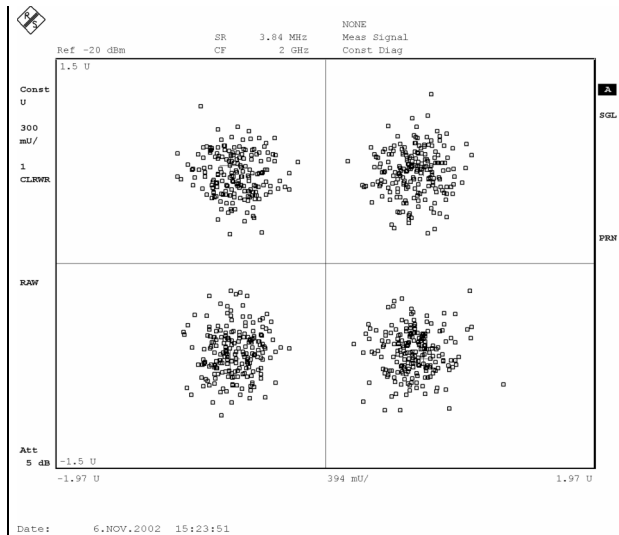

Fig. 250 Constellation diagram with superimposed noise in the event of underdrive

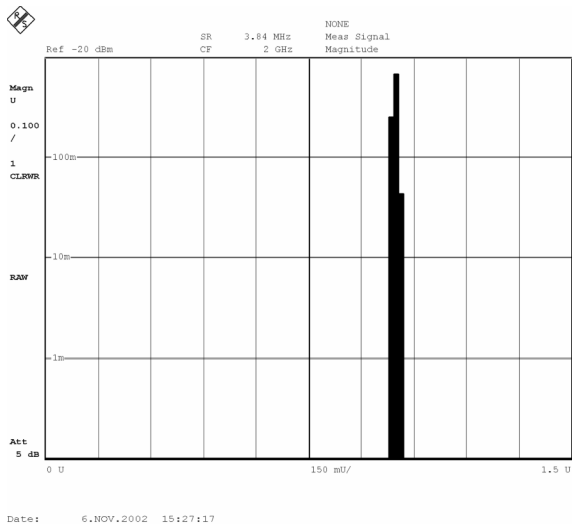

Fig. 251 Statistical distribution of magnitude error with correct modulation

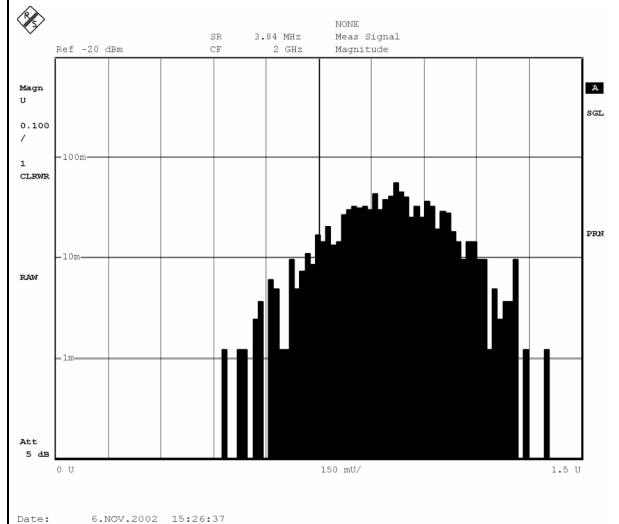

Fig. 252 Statistical distribution of magnitude error in the event of underdrive

Overdrive Condition of the Analyzer

Overdrive of the instrument is signalled by a message on the display and must in any case be avoided. When the unit is driven with input signals approx. 2 dB to 3 dB above the set reference level, clipping will start in the A/D converter in the analyzer measurement path.

Clipping is typically indicated by short-term sharp increases of the displayed EVM and by instability of the phase error in the AM/PM conversion diagram in the upper level range (reference level > 0 dB). Examples of this are shown in the figures below. The actual trace in the AM/PM conversion diagram fluctuates between the two extreme conditions shown below.

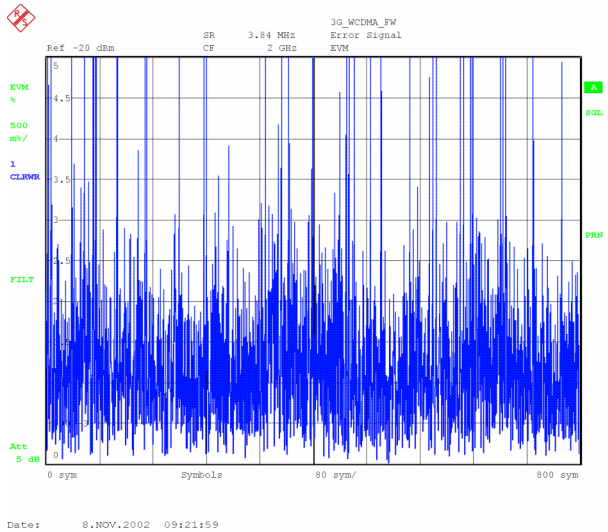

Fig. 253 Displayed EVM with overdrive condition

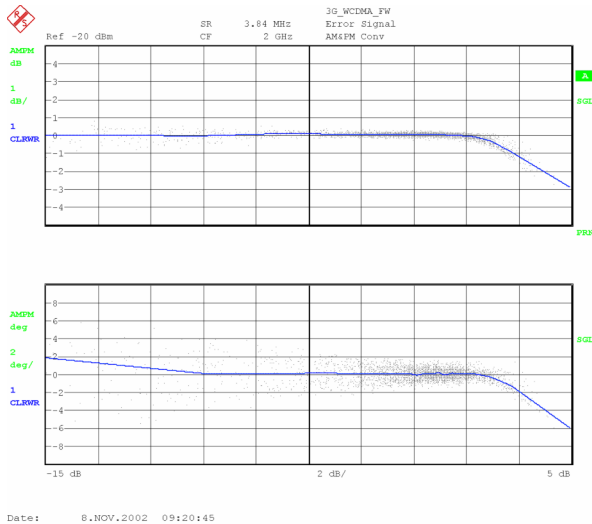

Fig. 254 Possible AM/PM conversion diagram with overdrive condition

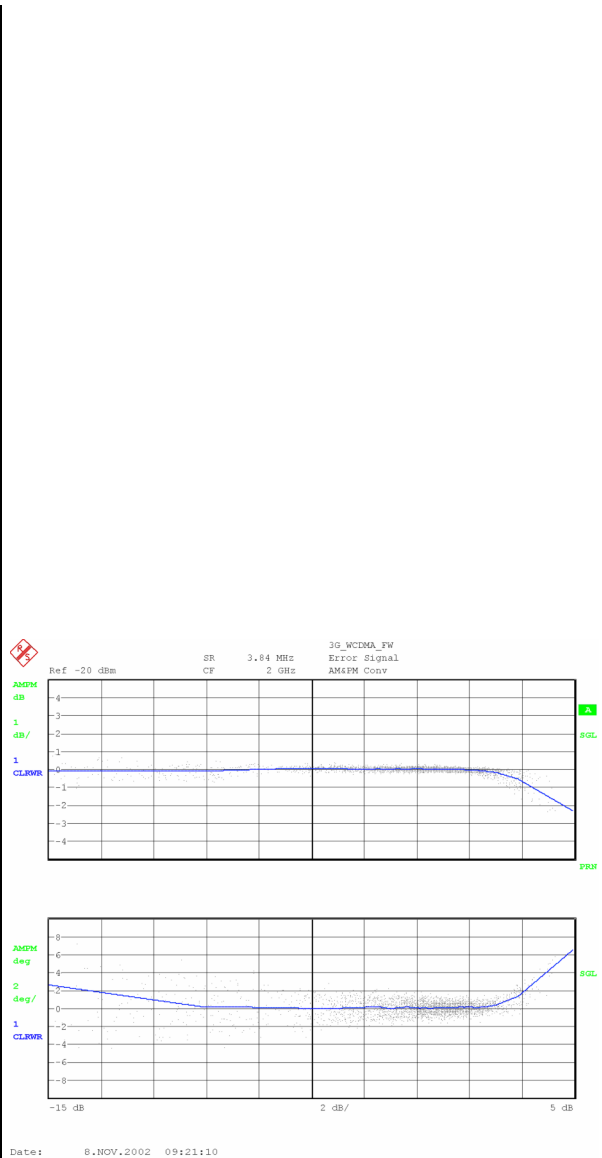

Fig. 255 Possible AM/PM conversion diagram with overdrive condition

6 Remote Control Commands

In the following sections, the commands for the operating mode Vector Signal Analysis (VSA), Option R&S FSQ-K70/FSMR-B73/FSU-B73, are first listed in a table according to the command subsystem and then described in detail. For the most part, the notation used complies with SCPI specifications. The SCPI conformance information is part of the command description.

The commands for the Analyzer R&S FSQ/FSU/FSUP/FSG or Measuring Receiver R&S FSMR are provided in the manual for the basic unit. The table in which the softkey is assigned to the IEC/IEEE bus command lists all commands that are required to execute this function. The table also includes the commands that are valid in the basic unit for other operating modes.

CALCulate Subsystem

The CALCulate subsystem contains commands for converting instrument data, transforming and carrying out corrections. These functions are carried out subsequent to data acquisition, i.e. following the SENSE subsystem.

The numeric suffix is used in CALCulate to make the distinction between the two measurement windows SCREEN A and SCREEN B:

CALCulate1 = Screen A
CALCulate2 = Screen B.

The vector signal analysis mode additionally includes the suffixes 3 and 4 in the case of CALCulate. Thus, a distinction is made between SCREEN C and SCREEN D:

CALCulate3 = Screen C
CALCulate4 = Screen D.

For commands without suffix, screen A is selected automatically.

Full Screen The settings are valid for the measurement window selected with the numeric suffix. They become effective as soon as the corresponding measurement window has been selected as active measurement window using the command `DISPlay[:WINDow<1|2>]:SElect`. Triggering measurements and querying measured values is possible only in the active measurement window.

Split Screen The settings are valid for the measurement window selected by means of the numeric suffix and become effective immediately.

CALCulate:DDEM Subsystem

COMMAND	PARAMETER	UNIT	COMMENT
CALCulate<1 2> :DDEM :SPECTrum [:STATe]	<Boolean>		

CALCulate<1|2>:DDEM:SPECTrum[:STATe] ON | OFF

This command switches the set result display to a spectral evaluation of the result parameter. Spectral evaluation is possible for the following result parameters:

Magnitude (:CALCulate<1|2>:FORMat MAGNitude)

Phase (:CALCulate<1|2>:FORMat PHASe | UPHase)

Frequency (:CALCulate<1|2>:FORMat FREQuency, MSK and FSK modulation only)

Real/Imag (:CALCulate<1|2>:FORMat RIMag)

Example:

```

":CALC:FEED 'XTIM:DDEM:MEAS" ' Selects the display of the
                               ' measurement signal
":CALC:FORM PHAS"           ' Selects the display of the phase
":CALC:DDEM:SPEC:STAT ON"  ' Selects the display of the spectral
                               ' distribution of the phase
    
```

Characteristics: *RST-value: OFF
SCPI: device-specific

CALCulate:FEED Subsystem

The CALCulate:FEED subsystem selects the type of evaluation for the measured data. This corresponds to the selection of the result display in manual operation.

COMMAND	PARAMETER	UNIT	COMMENT
CALCulate<1 2> :FEED	<string>		no query

CALCulate<1|2>:FEED <string>

This command selects the measured data to be displayed.

Parameters for Option R&S FSQ-K70/FSMR-B73/FSU-B73:

'XTIM:DDEM:MEAS'	Result display of measurement signal (synchronized to symbol clock)
'XTIM:DDEM:REF'	Result display of reference signal (internally generated from demodulated measurement signal)
'XTIM:DDEM:ERR:MPH'	Result display of error signal (magnitude and phase error)
'XTIM:DDEM:ERR:VECT'	Result display of vector error signal
'XTIM:DDEMod:IMPuls'	Result display of equalizer for magnitude, phase and real/imag
'XFR:DDEMod:RAT'	Result display of equalizer for phase and frequency response
'XFR:DDEMod:IRAT'	Result display of equalizer for channel response
'XTIM:DDEM:SYMB'	Symbol table (demodulated bits and table with modulation errors)
'TCAP'	Result display of measurement signal in capture buffer

Example: ":CALC:FEED 'XTIM:DDEM:ERR:VECT' " ' Selects the display of
'the vector error signal.

Characteristics: *RST value: 'XTIM:DDEM:MEAS'
SCPI: conforming

CALCulate:FORMat Subsystem

The CALCulate:FORMat subsystem determines the postprocessing and conversion of measured data. The measurement window is selected via CALCulate1 (SCREEN A) or CALCulate2 (SCREEN B). The subsystem is available only in the operating mode Vector Signal Analysis with Option R&S FSE-K70.

COMMAND	PARAMETER	UNIT	COMMENT
CALCulate<1 2> :FORMat	MAGNitude PHASe UPHase RIMag FREQuency IEYE QEYE COMP CONS CONVersion GEDelay		
:FSK :DEViation :REFerence :COMPensation	<numeric_value> ON OFF	HZ	

:CALCulate<1|2>:FORMat MAGNitude | PHASe | UPHase | RIMag | FREQuency | IEYE | QEYE | COMP | CONS | CONVersion | GDElay

This command defines the display of traces.

Example: " :CALC:FORM CONS "

Characteristics: *RST value: MAGNitude
SCPI: conforming

The availability of the parameters depends on the setting under CALCulate:FEED:

Can be set when the modulation error (ERROR SIGNAL), the measurement signal (MEAS SIGNAL) and the reference signal (REFERENCE SIGNAL) are displayed.

MAGNitude Display of magnitude over time.

PHASe | UPHase Display of phase over time with or without ("unwrapped").
Limitation to ±180°.

RIMag Display of inphase or quadrature component over time.

FREQuency Display of frequency over time.

COMP Display of polar vector diagram (complex).

CONS Display of polar vector diagram (constellation).

GEDelay Display of equalizer data as group delay

Can be set if the measurement signal (MEAS SIGNAL) and the reference signal is displayed (REFERENCE SIGNAL).

IEYE | QEYE Eye diagram of inphase and quadrature component.

Can be set if the modulation error (ERROR SIGNAL) is displayed.

CONVersion Display of AM & PM conversion.

CALCulate<1|2>:FSK:DEViation:REFerence <numeric_value>

This command defines the reference value of the frequency deviation for FSK modulation.

Example: "CALC:FSK:DEV:REF 20kHz"

Characteristics: *RST value: -
SCPI: device-specific

CALCulate<1|2>:FSK:DEVIation:COMPensation ON | OFF

This command selects the method for calculating the frequency error for FSK modulation.

Parameter: ON Scales the reference signal to the actual deviation of the measurement signal
OFF Uses the entered nominal deviation for the reference signal

Example: "CALC:FSK:DEV:COMP ON"

Characteristics: *RST value: OFF
SCPI: device-specific

This command is only available for FSK modulation.

CALCulate:ELIN Subsystem

The CALCulate:ELIN subsystem determines the evaluation range. The measurement window is selected via CALCulate1 (SCREEN A) or CALCulate2 (SCREEN B).

COMMAND	PARAMETER	UNIT	COMMENT
CALCulate<1 2> :ELIN<1 2> :STATe	<numeric_value> <Boolean>	SYM	

:CALCulate<1|2>:ELIN<1|2> <numeric_value>

This command defines the position of the evaluation line in the diagram. The evaluation line limits the evaluation range for numeric parameters.

Example: "CALC:ELIN 5SYM"

Characteristics: *RST value: - (STATe to OFF)
SCPI: device-specific

:CALCulate<1|2>:ELIN<1|2>:STATe ON | OFF

The command switches both evaluation lines on or off. The suffix under ELIN is irrelevant.

Example: "CALC:ELIN:STAT OFF" ' Switches the evaluation line off.

Characteristics: *RST value: OFF
SCPI: device-specific

CALCulate:MARKer:FUNcTION Subsystem

The CALCulate:MARKer:FUNcTION subsystem includes the marker functions for Option R&S FSQ-K70/FSMR-B73/FSU-B73.

Command	Parameter	Unit	Comment
CALCulate<1 2> :MARKer<1...4> :FUNcTION :CPOint [:STATe] :VALue :PHDiff? :POWer? :DATA? :DDEMod :RESult? :STATistic :ADRoop :CFERror :DTTStart :EVM :FSK :CFDRift :DERRor :MDEviation :GIMBalance :IQIMbalance :MERRor :MPOWer :OOffset :PERRor :PLERror :QERRor :RHO :SNR	<Boolean> <numeric_value> -- -- -- MERM MEPK MEPS PERM PEPK PEPS EVRM EVPK EVPS IQOF IQIM ADR FERR DEV FSRM FSPK FSPS RHO FEPK DTTS <none> RMS AVG SDEV <none> RMS AVG SDEV TPEak <none> RMS AVG SDEV <none> PEAK ASYM RMS AVG SDEV PCTL TPEak <none> RMS AVG SDEV <none> PEAK ASYM RMS AVG SDEV TPEak <none> RMS AVG SDEV <none> RMS AVG SDEV <none> PEAK ASYM RMS AVG SDEV TPEak <none> RMS AVG SDEV <none> PEAK ASYM RMS AVG SDEV TPEak <none> RMS AVG SDEV <none> RMS AVG SDEV <none> RMS AVG SDEV	DB	Query only Query only Query only Query only

CALCulate<1|2>:MARKer<1...4>:FUNCTION:CPOint[:STATE] ON | OFF

This command activates compression point measurement. Compression points can be measured only in the AM/PM diagram.

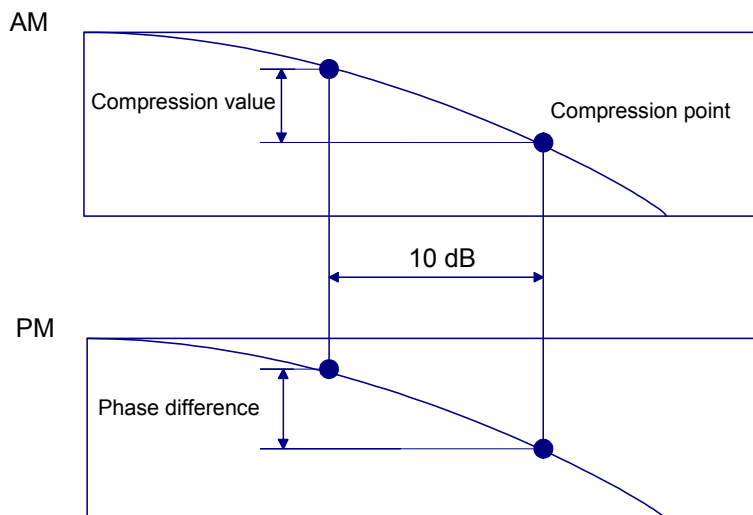

The compression value is set with `CALC:MARK:FUNC:CPO:VAL`.
 The compression point is queried with `CALC:MARK:FUNC:CPO:POW?`.
 The phase difference is queried with `CALC:MARK:FUNC:CPO:PHD?`.

Example: `"CALC:MARK:FUNC:CPO ON"` 'activates compression point measurement

Characteristics: *RST value: OFF
 SCPI: device-specific

The numeric suffix for MARKer has no meaning with this command.

CALCulate<1|2>:MARKer<1...4>:FUNCTION:CPOint:VALue <numeric_value>

This command defines the compression value of the compression point measurement.

Example: `"CALC:MARK:FUNC:CPO:VAL 3"` 'sets the compression value to 3 dB

Characteristics: *RST value: 1 dB
 SCPI: device-specific

The numeric suffix for MARKer has no meaning with this command.

CALCulate<1|2>:MARKer<1...4>:FUNCTION:CPOint:PHDiff?

This command queries the phase shift in the compression point measurement.

Example: `"INIT:CONT OFF"` 'switches to Single Sweep mode
`"CALC:MARK:FUNC:CPO:VAL 3"` 'sets the compression point to 3 dB
`"CALC:MARK:FUNC:CPO ON"` 'activates compression point measurement
`"INIT;*WAI"` 'starts a sweep and waits for the end
`"CALC:MARK:FUNC:CPO:PHD?"` 'outputs the result for phase difference

Characteristics: *RST value: -
 SCPI: device-specific

This command is a query only and thus has no *RST value. The numeric suffix for MARKer has no meaning with this command.

CALCulate<1|2>:MARKer<1...4>:FUNction:CPOint:POWer?

This command queries the compression point in dBm.

Example:

"INIT:CONT OFF"	'switches to Single Sweep mode
"CALC:MARK:FUNC:CPO:VAL 3"	'sets the compression point to 3 dB
"CALC:MARK:FUNC:CPO ON"	'activates compression point measurement
"INIT;*WAI"	'starts a sweep and waits for the end
"CALC:MARK:FUNC:CPO:POW?"	'outputs the result for compression point

Characteristics: *RST value: -
SCPI: device-specific

This command is a query only and thus has no *RST value. The numeric suffix for MARKer has no meaning with this command.

CALCulate<1|2>:MARKer<1...4>:FUNction:CPOint:DATA?

This command queries the other results in the compression point measurement. Six results are returned for this command.

<Ref Mean Pwr>, <Meas Mean Pwr>, <Cmp Mean Pwr>, <Ref Crest>, <Meas Crest>, <Cmp Crest>, <reserved1>, <reserved2>

Ref Mean Pwr:	Theoretical power of the ref signal + additional gain from AM/PM diag.
Meas Mean Pwr:	Measured mean power
Cmp Mean Pwr:	Power loss at current modulation
Ref Crest:	Crest factor of the ideal signal
Meas Crest:	Crest factor of the measured signal at current modulation
Cmp Crest:	Difference of the crest factors
<reserved1 2>	reserved for expansion

Example:

"INIT:CONT OFF"	'switches to Single Sweep mode
"CALC:MARK:FUNC:CPO:VAL 3"	'sets compression value to 3 dB
"CALC:MARK:FUNC:CPO ON"	'activates compression point measurement
"INIT;*WAI"	'starts a sweep and waits for the end
"CALC:MARK:FUNC:CPO:DATA?"	'query of results

Characteristics: *RST value: -
SCPI: device-specific

This command is a query only and thus has no *RST value. The numeric suffix for MARKer has no meaning with this command.

CALCulate<1|2>:MARKer<1...4>:FUNCTION:DDEMod:RESult?

MERM | MEPK | MEPS | PERM | PEPK | PEPS | EVRM | EVPK | EVPS | IQOF | IQIM |
ADR | FERR | FEPK | RHO | DEV | FSRM | FSPK | FSPS | DTTS

This command queries the results of the error measurement carried out for digital demodulation. The output values are the same values as those offered when selecting modulation accuracy (softkey SYMBOLS & MOD ACC) in manual operation. Marker values can be read with the CALCulate<1|2>: MARKer<1...4>:Y? command; trace data with the TRACe [:DATA] command.

Important: This command is available only to ensure compatibility with the R&S FSE and will no longer be supported in later versions. Use the new commands under CALC:MARK:FUNC:DDEM:STAT

Example: " :CALC:MARK:FUNC:DDEM:RES? EVRM" Queries the vector error in %rms.

Characteristics	*RST value: -		
	SCPI: device-specific		
MERM	Magnitude error in %rms	FERR	Frequency error in Hz.
MEPK	Magnitude error maximum in %pk	FEPK	Frequency error maximum in Hz.
MEPS	Symbol number for which the magnitude error maximum has occurred.	ADR	Amplitude droop in dB/symbol.
PERM	Phase error in deg.	RHO	Rho-Faktor
PEPK	Phase error maximum in deg.		
PEPS	Symbol number for which the dphase error maximum has occurred.	DEV	FSK deviation in Hz.
EVRM	Vector error in %rms.	FSRM	FSK deviation error in Hz.
EVPK	Vector error maximum in %pk.	FSPK	FSK deviation error maximum in Hz.
EVPS	Symbol number for which the vector error maximum has occurred.	FSPS	Symbol number for which the error maximum has occurred.
IQOF	I/Q offset error in %.	DTTS	Trigger delay to sync seq.
IQIM	I/Q imbalance in %.		

This command is a query only and thus has no *RST value.

The numeric suffixes under CALCulate and MARKer are irrelevant for this command.

:CALCulate<1|2>:MARKer<1...4>:FUNCTION:DDEM:STATistic:ADRoop? <none>| RMS| AVG| SDEV

This command queries the results of the amplitude droop error measurement performed for digital demodulation. The output values are the same values as those offered when selecting modulation accuracy (softkey SYMBOLS & MOD ACC).

<none>	Amplitude droop in dB/symbol.
RMS	Amplitude droop in dB/symbol, evaluating the rms over several sweeps.
AVG	Amplitude droop in dB/symbol, evaluating the linear average value over several sweeps.
SDEV	Standard deviation of amplitude droop.

Example: " :CALC:MARK:FUNC:DDEM:STAT:ADR? " 'Queries the amplitude 'droop.

Characteristics *RST value: -
SCPI: device-specific

The numeric suffixes under CALCulate and MARKer are irrelevant for this command.

:CALCulate<1|2>:MARKer<1...4>:FUNCtion:DDEM:STATistic:CFERror? <none> | RMS | AVG | SDEV | TPEak

This command queries the results of the carrier frequency error measurement performed for digital demodulation. The output values are the same values as those offered when selecting modulation accuracy (softkey SYMBOLS & MOD ACC).

<none>	Frequency error in Hz.
RMS	Frequency error in Hz, evaluating the rms over several sweeps.
AVG	Frequency error in Hz, evaluating the linear average value over several sweeps.
SDEV	Standard deviation of frequency error maximum.
TPEak	Extreme value of all frequency error maxima.

Example: ":CALC:MARK:FUNC:DDEM:STAT:CFER?" 'Queries the frequency
'error'

Characteristics *RST value: -
 SCPI: device-specific

The numeric suffixes under CALCulate and MARKer are irrelevant for this command.

:CALCulate<1|2>:MARKer<1...4>:FUNCtion:DDEM:STATistic:DTTStart? <none>|RMS| AVG| SDEV

This command queries the results of the trigger delay having an effect on the sync sequence of digital demodulation. The output values are the same values as those offered when selecting modulation accuracy (softkey SYMBOLS & MOD ACC).

<none>	Trigger delay in s.
RMS	Trigger delay in s, evaluating the rms over several sweeps.
AVG	Trigger delay in s, evaluating the linear average value over several sweeps.
SDEV	Standard deviation of trigger delay.

Example: ":CALC:MARK:FUNC:DDEM:STAT:DTTS?" 'Trigger delay

Characteristics *RST value: -
 SCPI: device-specific

The numeric suffixes under CALCulate and MARKer are irrelevant for this command.

:CALCulate<1|2>:MARKer<1...4>:FUNCtion:DDEM:STATistic:FSK:DERRor? <none> | PEAK | ASYM | RMS | AVG | SDEV | TPEak

This command queries the results of the FSK deviation error of digital demodulation. The output values are the same values as those offered when selecting modulation accuracy (softkey SYMBOLS & MOD ACC).

<<none>	FSK deviation error in Hz.
PEAK	FSK deviation error maximum in Hz.
ASYM	Symbol number for which the maximum has occurred.
RMS	FSK deviation error in Hz, evaluating the rms over several sweeps.
AVG	FSK deviation error in Hz, evaluating the linear average value over several sweeps.
SDEV	Standard deviation of FSK deviation error.
TPEak	Extreme value of all FSK deviation errors.

This command is only available for FSK demodulation.

Example: ":DDEM:FORM FSK" 'Modulation mode FSK
 ":CALC:MARK:FUNC:DDEM:STAT:FSK:DERR?"
 'Queries the FSK deviation error

Characteristics *RST value: -
 SCPI: device-specific

The numeric suffixes under CALCulate and MARKer are irrelevant for this command.

:CALCulate<1|2>:MARKer<1...4>:FUNCtion:DDEM:STATistic:FSK:MDEViation? none> | RMS | AVG | SDEV

This command queries the results of the FSK deviation of digital demodulation. The output values are the same values as those offered when selecting modulation accuracy (softkey SYMBOLS & MOD ACC).

<none>	FSK deviation in Hz.
RMS	FSK deviation in Hz, evaluating the rms over several sweeps.
AVG	FSK deviation in Hz, evaluating the linear average value over several sweeps.
SDEV	Standard deviation of FSK deviation.

This command is only available for FSK demodulation.

Example: ":DDEM:FORM FSK" 'Modulation mode FSK.
 ":CALC:MARK:FUNC:DDEM:STAT:FSK:MDEV?" 'FSK deviation.

Characteristics *RST value: -
 SCPI: device-specific

The numeric suffixes under CALCulate and MARKer are irrelevant for this command.

:CALCulate<1|2>:MARKer<1...4>:FUNCTION:DDEM:STATistic:MERRor? <none> | PEAK | ASYM | RMS | AVG | SDEV | TPEak

This command queries the results of the magnitude error measurement of digital demodulation. The output values are the same values as those offered when selecting modulation accuracy (softkey SYMBOLS & MOD ACC).

<none>	Magnitude error in %rms.
PEAK	Magnitude error maximum in%pk.
ASYM	Symbol number for which the magnitude error maximum has occurred.
RMS	Magnitude error in %, evaluating the rms over several sweeps.
AVG	Magnitude error in %, evaluating the linear average value over several sweeps.
SDEV	Standard deviation of magnitude error in %.
TPEak	Extreme value of all magnitude error maxima.

Example: " :CALC:MARK:FUNC:DDEM:STAT:MERR? PEAK"
' Queries the magnitude error maximum.

Characteristics *RST value: -
SCPI: device-specific

The numeric suffixes under CALCulate and MARKer are irrelevant for this command.

:CALCulate<1|2>:MARKer<1...4>:FUNCTION:DDEM:STATistic:MPOWER? <none> | PEAK | ASYM | RMS | AVG | SDEV | TPEak

This command queries the results of the power measurement of digital demodulation. The output values are the same values as those offered when selecting modulation accuracy (softkey SYMBOLS & MOD ACC).

Example: " :CALC:MARK:FUNC:DDEM:STAT:MPOW? PEAK"
'queries the power maximum

Characteristics *RST value: -
SCPI: device-specific

<none>	Power in dBm
PEAK	Power maximum in dBm.
ASYM	Symbol number for which the power maximum has occurred.
RMS	Power in dBm, evaluating the rms over several sweeps.
AVG	Power in dBm, evaluating the linear average value over several sweeps.
SDEV	Standard deviation of power in dBm.
TPEak	Extreme value of all power maxima.

The numeric suffixes under CALCulate and MARKer are irrelevant for this command.

:CALCulate<1|2>:MARKer<1...4>:FUNCtion:DDEM:STATistic:OOffset? <none> | RMS | AVG | SDEV

This command queries the results of the origin offset error measurement performed for digital demodulation. The output values are the same values as those offered when selecting modulation accuracy (softkey SYMBOLS & MOD ACC). This command is not available for FSK demodulation.

For FSK demodulation, this command is not available.

Important: The IQ offset was calculated instead of the origin offset for the R&S FSE. The interrelation between the origin offset and the IQ offset is as follows: $Origin-Offset = 20 * \log(IQ-Offset)$

Example: ":DDEM:FORM MSK" 'Modulation mode MSK
 ":CALC:MARK:FUNC:DDEM:STAT:OOff?" 'Queries the origin offset error

Characteristics *RST value: -
SCPI: device-specific

<none> Offset error in dB.
RMS Offset error in dB, evaluating the rms over several sweeps.
AVG Offset error in dB, evaluating the linear average value over several sweeps.
SDEV Standard deviation of offset error.

The numeric suffixes under CALCulate and MARKer are irrelevant for this command.

:CALCulate<1|2>:MARKer<1...4>:FUNCtion:DDEM:STATistic:PErRor? <none> | PEAK | ASYM | RMS | AVG | SDEV | TPEak

This command queries the results of the phase error measurement performed for digital demodulation. The output values are the same values as those offered when selecting modulation accuracy (softkey SYMBOLS & MOD ACC).

<none> Phase error in deg.
PEAK Phase error maximum in deg.
ASYM Symbol number for which the phase error maximum has occurred.
RMS Phase error in deg, evaluating the rms over several sweeps.
AVG Phase error in deg, evaluating the linear average value over several sweeps.
SDEV Standard deviation of phase error in deg.
TPEak Extreme value of all phase error maxima.

For FSK demodulation, this command is not available.

Example: ":DDEM:FORM MSK" 'Modulation mode MSK
 ":CALC:MARK:FUNC:DDEM:STAT:PErr?" 'Queries the phase error

Characteristics *RST value: -
SCPI: device-specific

The numeric suffixes under CALCulate and MARKer are irrelevant for this command.

:CALCulate<1|2>:MARKer<1...4>:FUNCTION:DDEM:STATistic:PLERror? <none> | RMS | AVG | SDEV

This command queries the results of the pilot level error measurement performed for digital demodulation. The output values are the same values as those offered when selecting modulation accuracy (softkey SYMBOLS & MOD ACC).

This command is only available for VSB demodulation.

Example: " :DDEM:FORM VSB" 'Modulation mode VSB
" :CALC:MARK:FUNC:DDEM:STAT:PLER?" 'Queries the pilot level error

Characteristics *RST value: -
SCPI: device-specific

<none> Pilot level error.
RMS Pilot level error, evaluating the rms over several sweeps.
AVG Pilot level error, evaluating the linear average value over several sweeps.
SDEV Standard deviation of pilot level error.

The numeric suffixes under CALCulate and MARKer are irrelevant for this command.

:CALCulate<1|2>:MARKer<1...4>:FUNCTION:STATistic:QERRor? <none> | RMS | AVG | SDEV

This command queries the results of the Quadratur error measurement performed for digital demodulation. The output values are the same values as those offered when selecting modulation accuracy (softkey SYMBOLS & MOD ACC).

For FSK demodulation, this command is not available.

Example: " :DDEM:FORM MSK" 'Modulation mode MSK
" :CALC:MARK:FUNC:DDEM:STAT:QERR?" 'Queries the Quadratur error

Characteristics *RST value: -
SCPI: device-specific

<none> Quadrature error in %.
RMS Quadrature error in %, evaluating the rms over several sweeps.
AVG Quadrature error in %, evaluating the linear average value over several sweeps
SDEV Standard deviation of Quadrature error

The numeric suffixes under CALCulate and MARKer are irrelevant for this command.

:CALCulate<1|2>:MARKer<1 to 4>:FUNction:SUMMary:MAXimum[:STATe] ON | OFF

This command switches on or off the measurement of the maximum of the absolute value.

Example: "CALC:MARK:FUNC:SUMM:MAX ON"

Characteristics: *RST value: OFF
SCPI: device-specific

CALCulate<1|2>:MARKer<1 to 4>:FUNction:SUMMary:MAXimum:RESult?

This command queries the results of the measurement of the maximum of the absolute value. Results of average calculation and peak hold are queried with commands to :MAXimum:AVERage:RESult? and to :MAXimum:PHOLd:RESult?.

Example: "CALC:MARK:FUNC:SUMM:MAX:RES?"

Characteristics: *RST value: -
SCPI: device-specific

This command is only a query and therefore has no *RST value.

CALCulate<1|2>:MARKer<1 to 4>:FUNction:SUMMary:MAXimum:AVERage:RESult?

This command is used to query the results of the measurement of the maximum of the absolute value if the average is calculated using the command CALCulate<1|2>:MARKer<1 to 4>:FUNction:SUMMary:AVERage.

Example: "CALC:MARK:FUNC:SUMM:MAX:AVER:RES?"

Characteristics: *RST value: -
SCPI: device-specific

This command is only a query and therefore has no *RST value.

CALCulate<1|2>:MARKer<1 to 4>:FUNction:SUMMary:MAXimum:PHOLd:RESult?

This command is used to query the results of the measurement of the maximum of the absolute value when the peak hold function is switched on with command CALCulate<1|2>:MARKer<1 to 4>:FUNction:SUMMary:PHOLd.

Example: "CALC:MARK:FUNC:SUMM:MAX:PHOL:RES?"

Characteristics: *RST value: -
SCPI: device-specific

This command is only a query and therefore has no *RST value.

CALCulate<1|2>:MARKer<1 to 4>:FUNction:SUMMary:PPEak[:STATe] ON | OFF

This command switches on or off the measurement of the positive peak value in the selected measurement window.

The function is independent of the marker selection, i.e. the numeric suffix <1 to 4> of MARKer is irrelevant. It is only available in the time domain (span = 0).

Example: "CALC:MARK:FUNC:SUMM:PPE ON" 'Switches on the function in screen A.

Characteristics: *RST value: OFF
SCPI: device-specific

CALCulate<1|2>:MARKer<1 to 4>:FUNCtion:SUMMary:PPEak:RESult?

This command is used to query the result of the measurement of the positive peak value in the selected measurement window. The measurement may have to be switched on previously.

The function is independent of the marker selection, i.e. the numeric suffix <1 to 4> of MARKer is irrelevant. It is only available in the time domain (span = 0).

A complete sweep with synchronization to sweep end must be performed between switching on the function and querying the measured value to obtain a valid query result. This is only possible in single sweep mode.

Example:

```
"INIT:CONT OFF"      'Switches to single-sweep mode.
"CALC:MARK:FUNC:SUMM:PPE ON"
                        'Switches on the function in screen A.
"INIT;*WAI"          'Starts a sweep and waits for the end.
"CALC:MARK:FUNC:SUMM:PPE:RES?"
                        'Outputs the result of screen A.
```

Characteristics: *RST value: -
SCPI: device-specific

This command is only a query and therefore has no *RST value.

CALCulate<1|2>:MARKer<1 to 4>:FUNCtion:SUMMary:PPEak:AVERAge:RESult?

This command is used to query the result of the measurement of the averaged positive peak value in the selected measurement window. The query is only possible if averaging has been activated previously using CALCulate<1|2>:MARKer<1 to 4>:FUNCtion:SUMMary:AVERAge.

The function is independent of the marker selection, i.e. the numeric suffix <1 to 4> in MARKer is irrelevant. It is only available in the time domain (span = 0).

A complete sweep with synchronization to sweep end must be performed between switching on the function and querying the measured value to obtain a valid query result. This is only possible in single sweep mode.

Example:

```
"INIT:CONT OFF"      'Switches to single-sweep mode.
"CALC:MARK:FUNC:SUMM:PPE ON"
                        'Switches on the function in screen A.
"CALC:MARK:FUNC:SUMM:AVER ON"
                        'Switches on the calculation of average 'in screen A.
"INIT;*WAI"          'Starts a sweep and waits for the end.
"CALC:MARK:FUNC:SUMM:PPE:AVER:RES?"
                        'Outputs the result of screen A.
```

Characteristics: *RST value: -
SCPI: device-specific

This command is only a query and therefore has no *RST value.

CALCulate<1|2>:MARKer<1 to 4>:FUNction:SUMMary:PPEak:PHOLd:RESult?

This command is used to query the result of the measurement of the positive peak value with active peak hold function. The query is only possible if the peak hold function has been activated previously using CALCulate<1|2>:MARKer<1 to 4>: FUNction:SUMMary:PHOLd.

The function is independent of the marker selection, i.e. the numeric suffix <1 to 4> of :MARKer is irrelevant. It is only available in the time domain (span = 0).

A complete sweep with synchronization to sweep end must be performed between switching on the function and querying the measured value to obtain a valid query result. This is only possible in single sweep mode.

Example:

"INIT:CONT OFF"	'Switches to single-sweep mode.
"CALC:MARK:FUNC:SUMM:PPE ON"	'Switches on the function in screen A.
"CALC:MARK:FUNC:SUMM:PHOL ON"	'Switches on the measurement of the peak value in screen A.
"INIT;*WAI"	'Starts a sweep and waits for the end.
"CALC:MARK:FUNC:SUMM:PPE:PHOL:RES?"	'Outputs the result of screen A.

Characteristics: *RST value: -
SCPI: device-specific'

This command is only a query and therefore has no *RST value.

CALCulate<1|2>:MARKer<1 to 4>:FUNction:SUMMary:MPEak[:STATe] ON | OFF

This command switches on or off the measurement of the negative peak value.

Example: "CALC:MARK:FUNC:SUMM:MPE ON"

Characteristics: *RST value: OFF
SCPI: device-specific

CALCulate<1|2>:MARKer<1 to 4>:FUNction:SUMMary:MPEak:RESult?

This command queries the result of the measurement of the negative peak value in the selected measurement window. Results of average calculation and peak hold are queried with commands to :MPEak:AVERAge:RESult? and to :MPEak:PHOLd:RESult?.

Example: "CALC:MARK:FUNC:SUMM:MPE:RES?"

Characteristics: *RST- value: -
SCPI: device-specific

This command is only a query and therefore has no *RST value.

CALCulate<1|2>:MARKer<1 to 4>:FUNction:SUMMary:MPEak:AVERAge:RESult?

This command queries the result of the measurement of the negative peak value in the selected measurement window if the average is calculated using the command CALCulate<1|2>:MARKer<1 to 4>:FUNction: SUMMary:AVERAge.

Example: "CALC:MARK:FUNC:SUMM:MPE:AVER:RES?"

Characteristics: *RST- value: -
SCPI: device-specific

This command is only a query and therefore has no *RST value.

CALCulate<1|2>:MARKer<1 to 4>:FUNCtion:SUMMary:MPEak:PHOLd:RESult?

This command queries the result of the measurement of the negative peak value in the selected measurement window if the peak hold function is switched on with command
CALCulate<1|2>:MARKer<1 to 4>: FUNCtion:SUMMary:PHOLd.

Example: "CALC:MARK:FUNC:SUMM:MPE:RES?"

Characteristics: *RST- value: -
SCPI: device-specific

This command is only a query and therefore has no *RST value.

CALCulate<1|2>:MARKer<1 to 4>:FUNCtion:SUMMary:MIDDLE[:STATe] ON | OFF

This command switches on or off the measurement of the arithmetical mean between positive and negative peak value in the selected measurement window.

Example: "CALC:MARK:FUNC:SUMM:MIDD ON"

Characteristics: *RST value: OFF
SCPI: device-specific

CALCulate<1|2>:MARKer<1 to 4>:FUNCtion:SUMMary:MIDDLE:RESult?

This command queries the result of the measurement of the arithmetical mean between positive and negative peak value in the selected measurement window. Results of average calculation and peak hold are queried with commands ...:MIDDLE:AVERAge:RESult? and ...:MIDDLE:PHOLd:RESult?.

Example: "CALC:MARK:FUNC:SUMM:MIDD:RES? "

Characteristics: *RST- value: -
SCPI: device-specific

This command is only a query and therefore has no *RST value

CALCulate<1|2>:MARKer<1 to 4>:FUNCtion:SUMMary:MIDDLE:AVERAge:RESult?

This command queries the result of the measurement of the arithmetical mean between positive and negative peak value in the selected measurement window if the average is calculated using the command CALCulate<1|2>: MARKer<1 to 4>:FUNCtion:SUMMary:AVERAge.

Example: "CALC:MARK:FUNC:SUMM:MIDD:AVER:RES?"

Characteristics: *RST- value: -
SCPI: device-specific

This command is only a query and therefore has no *RST value

CALCulate<1|2>:MARKer<1 to 4>:FUNCtion:SUMMary:MIDDLE:PHOLd:RESult?

This command queries the result of the measurement of the arithmetical mean between positive and negative peak value in the selected measurement window if the peak hold function is switched on using the command CALCulate<1|2>:MARKer<1 to 4>:FUNCtion:SUMMary:PHOLd.

Example: "CALC:MARK:FUNC:SUMM:MIDD:PHOL:RES?"

Characteristics: *RST- value: -
SCPI: device-specific

This command is only a query and therefore has no *RST value

CALCulate<1|2>:MARKer<1 to 4>:FUNction:SUMMary:RMS[:STATe] ON | OFF

This command switches on or off the measurement of the effective (RMS) power in the selected measurement window. If necessary the function is switched on previously.

The function is independent of the marker selection, i.e. the numeric suffix <1 to 4> of :MARKer is irrelevant. It is only available in the time domain (span = 0).

Example: "CALC2:MARK:FUNC:SUM:RMS ON" 'Switches on the function in screen B.

Characteristics: *RST value: OFF
SCPI: device-specific

CALCulate<1|2>:MARKer<1 to 4>:FUNction:SUMMary:RMS:RESult?

This command queries the result of the measurement of the RMS power value in the selected measurement window.

The function is independent of the marker selection, i.e. the numeric suffix <1 to 4> of :MARKer is irrelevant. It is only available in the time domain (span = 0).

A complete sweep with synchronization to sweep end must be performed between switching on the function and querying the measured value to obtain a valid query result. This is only possible in single sweep mode.

Example: "INIT:CONT OFF" 'Switches to single-sweep mode.
"CALC:MARK:FUNC:SUMM:RMS ON" 'Switches on the function in screen A.
"INIT;*WAI" 'Starts a sweep and waits for the end.
"CALC:MARK:FUNC:SUMM:RMS:RES?" 'Outputs the result of screen A.

Characteristics: *RST- value: -
SCPI: device-specific

This command is only a query and therefore has no *RST value.

CALCulate<1|2>:MARKer<1 to 4>:FUNction:SUMMary:RMS:AVERage:RESult?

This command queries the result of the measurement of the averaged RMS value in the selected measurement window. The query is only possible if averaging has been activated previously using CALCulate<1|2>:MARKer<1 to 4>:FUNction:SUMMary:AVERage.

The function is independent of the marker selection, i.e. the numeric suffix <1 to 4> of :MARKer is irrelevant. It is only available in the time domain (span = 0).

A complete sweep with synchronization to sweep end must be performed between switching on the function and querying the measured value to obtain a valid query result. This is only possible in single sweep mode.

Example: "INIT:CONT OFF" 'Switches to single-sweep mode.
"CALC:MARK:FUNC:SUMM:RMS ON" 'Switches on the function in screen A.
"CALC:MARK:FUNC:SUMM:AVER ON" 'Switches on the average value
'calculation in screen A.
"INIT;*WAI" 'Starts a sweep and waits for the end.
"CALC:MARK:FUNC:SUMM:RMS:AVER:RES?" 'Outputs the result of screen A.

Characteristics: *RST- value: -
SCPI: device-specific

This command is only a query and therefore has no *RST value.

CALCulate<1|2>:MARKer<1 to 4>:FUNction:SUMMary:RMS:PHOLd:RESult?

This command queries the result of the measurement of the RMS value with active peak hold in the selected measurement window. The query is only possible only if the peak hold function has been activated previously using CALCulate<1|2>:MARKer<1 to 4>: FUNction:SUMMary:PHOLd.

The function is independent of the marker selection, i.e. the numeric suffix <1 to 4> of :MARKer is irrelevant. It is only available in the time domain (span = 0).

A complete sweep with synchronization to sweep end must be performed between switching on the function and querying the measured value to obtain a valid query result. This is only possible in single sweep mode.

Example:

```
"INIT:CONT OFF" 'Switches to single-sweep mode.
"CALC:MARK:FUNC:SUMM:RMS ON" 'Switches on the function in screen A.
"CALC:MARK:FUNC:SUMM:PHOL ON" 'Switches on the peak value
                               'measurement in screen A.
"INIT;*WAI" 'Starts a sweep and waits for the end.
"CALC:MARK:FUNC:SUMM:RMS:PHOL:RES?" 'Outputs the result of screen A.
```

Characteristics: *RST- value: -
SCPI: device-specific

This command is only a query and therefore has no *RST value.

CALCulate<1|2>:MARKer<1 to 4>:FUNction:SUMMary:MEAN[:STATe] ON | OFF

This command switches on or off the measurement of the mean value in the selected measurement window.

The function is independent of the marker selection, i.e. the numeric suffix <1 to 4> of :MARKer is irrelevant. It is only available in the time domain (span = 0)..

Note: *The measurement is performed on the trace on which marker 1 is positioned. In order to evaluate another trace, marker 1 must be positioned on another trace with
CALC:MARK:TRAC 1|2|3.*

Example: "CALC:MARK:FUNC:SUMM:MEAN ON" 'Switches on the function in screen A.

Characteristics: *RST value: OFF
SCPI: device-specific

CALCulate<1|2>:MARKer<1 to 4>:FUNction:SUMMary:MEAN:RESult?

This command queries the result of the measurement of the mean value in the selected measurement window. The function is independent of the marker selection, i.e. the numeric suffix <1 to 4> of :MARKer is irrelevant. It is only available in the time domain (span = 0).

A complete sweep with synchronization to sweep end must be performed between switching on the function and querying the measured value to obtain a valid query result. This is only possible in single sweep mode.

Example:

```
"INIT:CONT OFF" 'Switches to single-sweep mode.
"CALC:MARK:FUNC:SUMM:MEAN ON" 'Switches on the function in screen A.
"INIT;*WAI" 'Starts a sweep and waits for the end.
"CALC:MARK:FUNC:SUMM:MEAN:RES?" 'Outputs the result of screen A.
```

Characteristics: *RST- value: -
SCPI: device-specific

This command is only a query and therefore has no *RST value.

CALCulate<1|2>:MARKer<1 to 4>:FUNCTion:SUMMary:MEAN:AVERAge:RESult?

This command queries the result of the measurement of the averaged mean value in the selected measurement window. The query is only possible if averaging has been activated previously using CALCulate<1|2>:MARKer<1 to 4>:FUNCTion: SUMMary:AVERAge.

The function is independent of the marker selection, i.e. the numeric suffix <1 to 4> of :MARKer is irrelevant. It is only available in the time domain (span = 0).

A complete sweep with synchronization to sweep end must be performed between switching on the function and querying the measured value to obtain a valid query result. This is only possible in single sweep mode.

Example:

```
"INIT:CONT OFF"      'Switches to single-sweep mode.
"CALC:MARK:FUNC:SUMM:MEAN ON"
                        'Switches on the function in screen A.
"CALC:MARK:FUNC:SUMM:AVER ON"
                        'Switches on the average value 'calculation in screen A.
"INIT;*WAI"          'Starts a sweep and waits for the end.
"CALC:MARK:FUNC:SUMM:MEAN:AVER:RES?"
                        'Outputs the result of screen A.
```

Characteristics: *RST- value: -
SCPI: device-specific

This command is only a query and therefore has no *RST value.

CALCulate<1|2>:MARKer<1 to 4>:FUNCTion:SUMMary:MEAN:PHOLd:RESult?

This command queries the result of the measurement of the mean value with active peak hold in the selected measurement window. The query is only possible if the peak hold function has been switched on previously using CALCulate<1|2>:MARKer<1 to 4>:FUNCTion:SUMMary:PHOLd.

The query is possible only if the peak hold function is active. The function is independent of the marker selection, i.e. the numeric suffix <1 to 4> of :MARKer is irrelevant. It is only available in the time domain (span = 0).

A complete sweep with synchronization to sweep end must be performed between switching on the function and querying the measured value to obtain a valid query result. This is only possible in single sweep mode.

Example:

```
"INIT:CONT OFF"      'Switches to single-sweep mode
"CALC:MARK:FUNC:SUMM:MEAN ON"
                        'Switches on the function in screen A
"CALC:MARK:FUNC:SUMM:PHOL ON"
                        'Switches on the peak value 'measurement in screen A
"INIT;*WAI"          'Starts a sweep and waits for the end
"CALC:MARK:FUNC:SUMM:MEAN:PHOL:RES?"
                        'Outputs the result of screen A.
```

Characteristics: *RST- value: -
SCPI: device-specific

This command is only a query and therefore has no *RST value.

CALCulate<1|2>:MARKer<1 to 4>:FUNCtion:SUMMary:SDEViation[:STATe] ON | OFF

This command switches on or off the measurement of the standard deviation in the selected measurement window. The function is independent of the marker selection, i.e. the numeric suffix <1 to 4> of :MARKer is irrelevant. It is only available in the time domain (span = 0)..

On switching on the measurement, the mean power measurement is switched on as well.

Example: "CALC2:MARK:FUNC:SUMM:SDEV ON" 'Switches on the measurement of the standard deviation in screen B.

Characteristics: *RST value: OFF
SCPI: device-specific

CALCulate<1|2>:MARKer<1 to 4>:FUNCtion:SUMMary:SDEViation:RESult?

This command queries the results of the standard deviation measurement. The function is independent of the marker selection, i.e. the numeric suffix <1 to 4> of :MARKer is irrelevant. It is only available in the time domain (span = 0).

A complete sweep with synchronization to sweep end must be performed between switching on the function and querying the measured value to obtain a valid query result. This is only possible in single sweep mode.

Example: "INIT:CONT OFF" 'Switches to single-sweep mode.
"CALC:MARK:FUNC:SUMM:SDEV ON" 'Switches on the function in screen A.
"INIT;*WAI" 'Starts a sweep and waits for the end.
"CALC:MARK:FUNC:SUMM:SDEV:RES?" 'Outputs the result of screen A.

Characteristics: *RST value: -
SCPI: device-specific

This command is only a query and therefore has no *RST value.

CALCulate<1|2>:MARKer<1 to 4>:FUNCtion:SUMMary:SDEViation:AVERage:RESult?

This command queries the result of the averaged standard deviation determined in several sweeps in the selected measurement window. The query is possible only if averaging is active. The function is independent of the marker selection, i.e. the numeric suffix <1 to 4> of :MARKer is irrelevant. It is only available in the time domain (span = 0).

A complete sweep with synchronization to sweep end must be performed between switching on the function and querying the measured value to obtain a valid query result. This is only possible in single sweep mode.

Example: "INIT:CONT OFF" 'Switches to single-sweep mode.
"CALC:MARK:FUNC:SUMM:SDEV ON" 'Switches on the function in screen A.
"CALC:MARK:FUNC:SUMM:AVER ON" 'Switches on the calculation of average
'in screen A.
"INIT;*WAI" 'Starts a sweep and waits for the end.
"CALC:MARK:FUNC:SUMM:MEAN:SDEV:RES?" 'Outputs the result of screen A.

Characteristics: *RST value: -
SCPI: device-specific

This command is only a query and therefore has no *RST value.

CALCulate<1|2>:MARKer<1 to 4>:FUNCtion:SUMMery:SDEViation:PHOLd:RESult?

This command queries the maximum standard deviation value determined in several sweeps in the selected measurement window. The query is possible only if the peak hold function is active.

The function is independent of the marker selection, i.e. the numeric suffix <1 to 4> of :MARKer is irrelevant. It is only available in the time domain (span = 0).

A complete sweep with synchronization to sweep end must be performed between switching on the function and querying the measured value to obtain a valid query result. This is only possible in single sweep mode.

Example:

```
"INIT:CONT OFF"      'Switches to single-sweep mode.
"CALC:MARK:FUNC:SUMM:SDEV ON" 'Switches on the function in screen A.
"CALC:MARK:FUNC:SUMM:PHOL ON"  'Switches on the peak value
                                'measurement in screen A.
"INIT;*WAI"          'Starts a sweep and waits for the end.
"CALC:MARK:FUNC:SUMM:SDEV:PHOL:RES?"
                                'Outputs the result of screen A.
```

Characteristics: *RST value: -
SCPI: device-specific

This command is only a query and therefore has no *RST value.

CALCulate<1|2>:MARKer<1 to 4>:X:CONVersion:ABSolute?

This command returns the absolute X marker position for AM & PM conversion measurement. The value is returned in dBm. This function is only available for marker 1.

Example: "CALC1:MARK1:X:CONV?" 'Returns the absolute horizontal marker position.

Characteristics: *RST value: -
SCPI: device-specific

CALCulate:STATistics Subsystem

The CALCulate:STATistics subsystem controls the statistical measurement functions in the unit. With these measurement functions, the measurement window cannot be selected. The numeric suffix is therefore ignored under CALCulate.

COMMAND	PARAMETER	UNIT	COMMENT
CALCulate :STATistics :CCDF [:STATe] :SCALe :X :BCOunt	<Boolean> <numeric_value>		

CALCulate:STATistics:CCDF[:STATe] ON | OFF

This command switches the measurement of the statistical distribution of MAGNITUDE on or off.

Example: "CALC:STAT:CCDF ON" 'Switches the STATISTIC measurements on.

Characteristics: *RST value: OFF
SCPI: device-specific

:CALCulate:STATistics:SCALe:X:BCOunt <numeric_value>

This command defines the number of bars for the statistical functions. .

Example: "CALC:STAT:SCAL:X:BCO 10" ' Defines the number of bars to 10.

Characteristics: *RST value: 101
SCPI: device-specific

CALCulate:TRACe Subsystem

The CALCulate:TRACe subsystem defines the display of the trace within the measurement window.

COMMAND	PARAMETER	UNIT	COMMENT
CALCulate<1 2> :TRACe<1..3> :ADJust :ALIGnment :VALue :OFFSet	AUTO TRIGger BURSt PATTern LEFT CENTer RIGHT <numeric_value> <numeric_value>	 % SYM	

:CALCulate<1|2>:TRACe<1..3>:ADJust AUTO | TRIGGer | BURSt | PATTern

This command defines the reference point for the display.

Parameter: AUTO The unit selects the reference point and the alignment.
TRIGger The reference point is the trigger time.
BURSt The reference point is the burst.

Example: ":CALC:TRAC:ADJ TRIG" Defines the reference point as trigger time.

Characteristics: *RST value: AUTO
SCPI: device-specific

:CALCulate<1|2>:TRACe<1..3>:ADJust:ALIGnment LEFT | CENTer | RIGHT

This command defines where the relevant event (reference point) is to appear in the diagram.

Parameter: LEFT The reference point is displayed at the left edge of the display.
CENTer The reference point is displayed in the middle of the display.
RIGHT The reference point is displayed at the right edge of the display.

Example: ":CALC:TRAC:ADJ:ALIG LEFT" 'Defines that the reference point is displayed at the left edge.

Characteristics: *RST value: CENTer
SCPI: device-specific

:CALCulate<1|2>:TRACe<1..3>:ADJust:ALIGnment:VALue 0 ... 100%

This command allows a shift of the reference point in the displayed range. The setting is made in percent relative to the size of the display range. This display range is normalized to 0% (left edge) and 100% (right edge). If the result length is changed, the percentage remains valid, and the absolute value in symbols for this shift is modified correspondingly.

Example: ":CALC:TRAC:ADJ:ALIG:VAL 50" 'The display is shifted by half the RESULT LENGTH to the right. The reference point is not changed.

Characteristics: *RST value: 0
SCPI: device-specific

:CALCulate<1|2>:TRACe<1..3>:ADJust:ALIGnment:OFFset <numeric value>

This command shifts the display range (relative to the reference time) by the number of given symbols. The resolution is 1 symbol. A value >0 results in a shift towards the right, and a value <0 results in a shift towards the left.

Example: ":CALC:TRAC:ADJ:ALIG:OFF 5" 'The display range is shifted by '5 symbols towards the right.

Characteristics: *RST value: 0
SCPI: device-specific

CALCulate:UNIT Subsystem

The UNIT subsystem is used to switch the basic unit of setting parameters. A distinction is made between UNIT1 (screen A) and UNIT2 (screen B).

COMMAND	PARAMETER	UNIT	COMMENT
CALCulate<1 2> :X :UNIT :TIME :UNIT :ANGLE :POWer	S SYM DEG RAD DBM V A W DBPW WATT DBUV DBMV VOLT DBUA AMPere DBUV_M DBUA_M		

CALCulate<1|2>:X:UNIT:TIME S | SYM

This command selects the default unit (symbols or seconds) for the x axis.

Example: "CALC:X:UNIT:TIME S"

Characteristics: *RST value: S
SCPI: device-specific

CALCulate<1|2>:UNIT:ANGLE DEG | RAD

This command selects the default unit for angles.

Example: "CALC:UNIT:ANGLE DEG"

Characteristics: *RST value: RAD
SCPI: device-specific

CALCulate<1|2>:UNIT:POWer DBM | V | A | W | DBPW | WATT | DBUV | DBMV | VOLT | DBUA | AMPere | DBUV_M | DBUA_M

This command selects the unit for power in the selected measurement window.

Example: "CALC:UNIT:POW DBM" 'Sets the power unit for screen A to dBm.

Characteristics: *RST value: dBm
SCPI: device-specific

DISPlay Subsystem

The DISPlay subsystem controls the selection and presentation of text-specific and graphics-specific information as well as measurement data on the screen.

The measurement window is selected via WINDow1 (SCREEN A) or WINDow2 (SCREEN B).

COMMAND	PARAMETER	UNIT	COMMENT
DISPlay [:WINDow<1 2>] :TRACe<1...3> :X [:SCALe] :PDIVision :RPOsition :RVALue :START :VOFFset :SYMBol	<numeric_value> <numeric_value> <numeric_value> DOTS BARS CROSSs OFF	S SYM PCT S SYM SYM	Query only

DISPlay[:WINDow<1|2>]:TRACe<1...3>:X[:SCALe]:PDIVision <numeric_value>

This command defines the scaling of the X axis.

Example: ":DISP:TRAC:X:PDIV 20SYM"

'Sets the scaling of the Y axis
'to 20 symbols/DIV.

Characteristics: *RST value: --
SCPI: device-specific

The numeric suffix under TRACe<1...3> is irrelevant.

DISPlay[:WINDow<1|2>]:TRACe<1...3>:X[:SCALe]: RPOsition 0...100PCT

This command defines the position of the reference value for the X axis.

Example: ":DISP:TRAC:X:RPOS 30PCT"

'The reference value is shifted
'by 30% towards the left.

Characteristics: *RST value: --
SCPI: device-specific

The numeric suffix under TRACe<1...3> is irrelevant.

DISPlay[:WINDow<1|2>]:TRACe<1...3>:X[:SCALe]:RVALue <numeric_value>

This command defines the reference value for the X axis of the measurement diagram.

Example: ":DISP:TRAC:X:RVAL 20SYM"

'Sets the reference value to 20
'symbols.

Characteristics: *RST value: 0
SCPI: device-specific

DISPlay[:WINDow<1|2>]:TRACe<1...3>:X[:SCALe]:STARt?

This command queries the first value of the X axis in symbols or time, depending on the unit setting for the X axis.

Note: In the "Fit Trace" menu (or with the CALC:TRAC:ALIG commands), the burst on the screen is shifted; the X axis thus no longer begins on the right at 0 symbols but at a selectable value

Example:

":CALC:TRAC:ADJ BURS"	'Defines the burst as the reference
	' for the screen display
":CALC:TRAC:ADJ:ALOG CENT"	'Position the burst at the center of the
	' screen.
":DISP:TRAC:X:STAR?"	'Queries the start value of the X axis

Characteristics: *RST value: 0
SCPI: device-specific

DISPlay[:WINDow<1|2>]:TRACe<1...3>:X[:SCALe]:VOFFset <numeric_value>

This command defines how to number the symbols for the X axis of the measurement diagram. This value is the symbol number at the right edge of the X axis.

Example: ":DISP:TRAC:X:VOFF 20" Sets the value at the right edge of the X axis to 20 symbols.

Characteristics: *RST value: 0
SCPI: device-specific

DISPlay[:WINDow<1|2>]:TRACe<1...3>:SYMBol DOTS | BARS | OFF

This command defines the display of the decision instants on the trace.

Example: ":DISP:WIND1:TRAC:SYMB DOTS" 'Defines that the decision instants are displayed in the form of dots.

Characteristics: *RST value: OFF
SCPI: device-specific'

DISPlay[:WINDow<1|2>]:TRACe<1...3>:Y:SPACing LINear | LOGarithmic | LDB

This command is used to allow switchover between a linear and a logarithmic scale in the selected measurement window. On a linear scale, switchover between the unit % (command DISP:WIND:TRAC:Y:SPAC LIN) and the unit dB (command DISP:WIND:TRAC:Y:SPAC LDB) is also possible.

The numeric suffix under TRACe<1...3> is irrelevant.

Example: ":DISP:WIND1:TRAC:Y:SPAC LIN"

Characteristics: *RST value: LOGarithmic
SCPI: conforming

FORMat Subsystem

The INSTRument subsystem selects the operating mode of the unit either via text parameters or fixed numbers.

COMMAND	PARAMETER	UNIT	COMMENT
FORMat			
[:DATA]	ASCIi REAL UINT[, <numeric_value>]		
:DEXPort			
:DSEParator	POINT COMMa		
:HEADer	<Boolean>		
:MODE	RAW TRACe		
:RAW			
:FORMat	ASCIi WAVeform BINary		

FORMat[:DATA] ASCIi | REAL| UINT [, 8 | 32]

This command specifies the data format for the data transmitted from the instrument to the control PC.

The data format is either ASCII or one of the formats REAL or UINT (Unsigned Integer). ASCII data are transmitted in plain text, separated by commas. REAL data are transmitted as 32-bit IEEE 754 floating-point numbers in the "definite length block format".

The format UINT is only used in operating mode vector signal analysis, for the symbol table.

The FORMat command is valid for the transmission of trace data. The data format of trace data received by the instrument is automatically recognized, regardless of the format which is programmed.

Format setting for the binary transmission of trace data (see also TRACE:DATA?):

Analyzer mode: REAL, 32

Vector analyzer: UINT, 8 with digital demodulation, symbol table
REAL, 32 otherwise

Note: *Incorrect format setting will result in numerical conversion, which may lead to incorrect results.*

Example:
"FORM REAL, 32"
"FORM ASC"
"FORM UINT, 8"

Characteristics: *RST value: ASCII
SCPI: conforming

FORMat:DEXPort:DSEParator POINT|COMMa

This command defines which decimal separator (decimal point or comma) is to be used for outputting measurement data to the file in ASCII format. Different languages of evaluation programs (e.g. MS-Excel) can thus be supported.

Example: "FORM:DEXP:DSEP POIN'Sets the decimal point as separator.

Characteristics: *RST value: -- (factory setting is POINT; *RST does not affect setting)
SCPI: device-specific

FORMat:DEXPort: DEXPort:HEADer ON | OFF

This command defines if a file header (including start frequency, sweep time, detector, etc.) is created or not. A small header with the instrument model, the version and the date is always transferred.

Example: "FORM:DEXP:HEAD OFF" 'only a small file header is transferred.'

Characteristics: *RST value: --
SCPI: device-specific

FORMat:DEXPort: MODE RAW | TRACe

This command defines which data are transferred, raw I/Q data or trace data.

Example: "FORM:DEXP:MODE RAW" 'raw measurement data are transferred.'

Characteristics: *RST value: TRACe
SCPI: device-specific

FORMat:DEXPort:RAW:FORMat ASCii | WAVeform | BINary

This command defines the output format of the RAW data file export function. Format WAV can be read e.g. by signal generator R&S SMIQ or R&S SMU.

ASCii ASCII file format

WAVeform Format WAV can be read e.g. by signal generator R&S SMU.

BINary Export der I/Q-Rohdaten sowie der benutzerdefinierten
Exports the I/Q RAW data and the VSA user parameter settings in a binary format.
Files saved with this format are loadable by function MMEM:LOAD:TRAC.
Note: The required harddisk space to store the I/Q RAW data depends on the RECORD LENGTH specified.

Example: "FORM:DEXP:MODE RAW" 'select RAW data export'
"FORM:DEXP:RAW:FORM WAV" 'select format waveform'
"MMEM:STOR:TRAC 1, 'D:\rawdat.wv'" 'start data export to file
'D:\rawdat.wv'

Characteristics: *RST value: ASCii
SCPI: device-specific

INSTRUMENT Subsystem

The INSTRUMENT subsystem selects the operating mode of the unit either via text parameters or fixed numbers.

COMMAND	PARAMETER	UNIT	COMMENT
:INSTRUMENT [:SElect] :NSElect	DDEMod SANalyzer 1 2		

INSTRUMENT[:SElect] DDEMod | SANalyzer

This command switches between the operating modes by means of text parameters.

Parameter: DDEMod Vector signal analysis
SANalyzer Spectrum analysis

Example: "CINST SAN" 'Switches the instrument to Spectrum Analyzer Mode.

Characteristics: *RST value: SANalyzer
SCPI: conforming

INSTRUMENT:NSElect 1 | 2

This command switches between the operating modes by means of numbers.

Parameter: 1: Spectrum analysis
2: Vector signal analysis

Example: "INST:NSEL 1" Switches the instrument to Spectrum Analyzer Mode.

Characteristics: *RST value: 1
SCPI: conforming

FORMAt:DEXPort:RAW:FORMAt ASCii | WAVeform

This command defines the output format of the RAW data file export function. Format WAV can be read e.g. by signal generator R&S SMIQ or R&S SMU.

Example: "FORM:DEXP:MODE RAW" 'select RAW data export
"FORM:DEXP:RAW:FORM WAV" 'select format waveform
"MMEM:STOR:TRAC 1, 'D:\rawdat.wv'" 'start data export to file
D:\rawdat.wv

Characteristics: *RST value: ASCii
SCPI: device-specific

MMEMory - Subsystem

COMMAND	PARAMETER	UNIT	COMMENT
MMEMory :LOAD :TRACe :STORe<1 2> :TRACe	1,<file_name> <file_name>		no Query

MMEMory: LOAD:TRACe 1,<file_name>

This command loads I/Q RAW data files. The file name includes indication of the path and the drive name. The path name complies with DOS conventions. This command is only available if RAW data with binary format is selected (“:FORM:DEXP:MODE RAW”, “:FORM:DEXP:RAW:FORM BIN”).

The command needs two different files, created with the MMEM:STOR:TRAC command).

<file_name>.VAV VSA-Einstellungen

<file_name>.bin I/Q-Rohdaten

The import of the I/Q RAW data requires the MULTI mode to be active (refer to HOME VSA → MEAS RESULT → CAPTURE BUFFER → ZOOM → MULTI for more details). This mode is automatically switched on with start of the load process.

Parameter: <file_name> ::= DOS-Dateiname

Example:

```

:INST:SEL DDEM          'enter VSA option additional commands to
                        'configure the measurement
:FORM:DEXP:MODE RAW    'select binary format
:FORM:DEXP:RAW:FORM BIN 'select binary format
:MMEM:STOR:TRAC 1, 'D:\vsa_raw'
                        'exports I/Q RAW data into two files:
                        'vsa_raw.vav (VSA settings) vsa_raw.bin (I/Q
                        'RAW data)

*RST '
:INST:SEL DDEM          'enter VSA
:FORM:DEXP:MODE RAW    'select RAW data to import
:FORM:DEXP:RAW:FORM BIN 'select binary format
:MMEM:LOAD:TRAC 1, 'D:\vsa_raw'
                        'import the I/Q RAW data files
                        'vsa_raw.vav (VSA settings)
                        'vsa_raw.bin (I/Q RAW data)

```

Characteristics: *RST value: -
SCPI: device-specific

This command is an event and therefore has no *RST value and no query.

MMEMory: STORE:TRACe 1,<file_name>

This command stores I/Q RAW data files. The file name includes indication of path and drive name. The path name complies with DOS conventions. This command is only available if RAW data with binary format is selected (“:FORM:DEXP:MODE RAW”, “:FORM:DEXP:RAW:FORM BIN”).

Parameter: <file_name> := DOS file name

Example:

```

:INST:SEL DDEM           'enter VSA option additional commands to
                          'configure the measurement
:FORM:DEXP:MODE RAW     'select binary format
:FORM:DEXP:RAW:FORM BIN 'select binary format
:MMEM:STOR:TRAC 1, 'D:\vsa_raw'
                          'exports I/Q RAW data into two files:
                          'vsa_raw.vav (VSA settings) vsa_raw.bin (I/Q
                          'RAW data)

*RST
:INST:SEL DDEM           'enter VSA
:FORM:DEXP:MODE RAW     'select RAW data to import
:FORM:DEXP:RAW:FORM BIN 'select binary format
:MMEM:LOAD:TRAC 1, 'D:\vsa_raw'
                          'import the I/Q RAW data files
                          'vsa_raw.vav (VSA settings)
                          'vsa_raw.bin (I/Q RAW data))

```

Characteristics: *RST value: -
SCPI: device-specific

This command is an event and therefore has no *RST value and no query.

SENSE Subsystem

SENSE:DDEMod Subsystem

This subsystem controls the parameters for digital Demodulation

COMMAND	PARAMETER	UNIT	COMMENT
[SENSE<1 2>] :DDEMod			
:ECALc	SYMBOL SIGNAL		
:OFFSet	<Boolean>		
:EQUalize	<Boolean>		
[:STATe]	<Boolean>		
:ADAPt	<numeric_value>		
:CNVRange	<string>		
:Length	<numeric_value>		
:LOAD	<string>		
:RESet			
:SAVE	<string>		
:EXPort			
:STANdard	<name>,<path>		
:MAPPing	<name>,<path>		
:PATTern	<name>,<path>		
:FILTer	<name>,<path>		
:EQUalizer	<string>,<string>		
:FACTory	ALL GSTandard STANdard MAPPing PATTern FILTer		
:FILTer			
[:STATe]	<Boolean>		
:ALPHA	<numeric_value>		
:CATalog?			Query only
:MODulation	<string>,<string>,<string>		
:FORMat	QPSK PSK MSK QAM FSK VSB UQAM		
:FSK			
:NSTate	2 4		
:IMPort			
:EQUalizer	<name>,<path>		
:FILTer	<name>,<path>		
:MAPPing	<name>,<path>		
:PATTern	<name>,<path>		
:STANdard	<name>,<path>		
:MAPPing	<file_name>		Query only
:CATalog?			
:MSK			
:FORMat	TYPE1 TYPE2 NORMAl DIFFerential		
:NORMalize	<Boolean>		
:PRATe	1 2 4 8 16		
:PRESet			
[:STANdard]	<file_name> APCO25C4FM APCO25CQPSK GSM EDGE FW3Gppcdma RW3Gppcdma FQCDma F95Cdma RQCDma R95Cdma CDMa2000 F1CDma2000 R1CDma2000 FNADc RNADc PDCCDown PDCup PHS TETRa DECT DCS1800 PCS1900		
:RLEVel			

COMMAND	PARAMETER	UNIT	COMMENT
[[:SENSE<1 2>]			
:DDEMod			
:PSK			
:FORMat	NORMal DIFFerential N3Pi8		
:NSTate	2 8		
:QAM			
:FORMat	NORMal DIFFerential		
:NSTate	16 32 64 128 256		
:QPSK			
:FORMat	NORMal DIFFerential OFFSet DPI4		
:RLENgth	<numeric_value>	S SYM	
:AUTO	<Boolean>		
:SBANd	NORMal INVerse		
:SEARch			
:BURSt			
:GLENgth			
[:MINimum]	<numeric_value>	S SYM	
:HYSTeresis			
[:LEVEl]	<numeric_value>	DB	
:LENgth			
[:MINimum]	<numeric_value>	S SYM	
:MAXimum	<numeric_value>	S SYM	
:MODE	MEAS BURSt		
:SKIP			
:RISing	<numeric_value>	S SYM	
:FALLing	<numeric_value>	S SYM	
[:STATe]	<Boolean>		
:THReshold			
[:LEVEl]	<numeric_value>	DB DBM	
:AUTO	<Boolean>		
:MODE	RELative ABSolute		
:MBURst			
:CAPTure			
:AUTO	<Boolean>		
:FIND			
:NEXT			no query
:FIRSt			no query
:STARt			no query
:LENgth	<numeric_value>		
:STARt	<numeric_value>	S SYM	
[:STATe]	<Boolean>	S SYM	
:SEARch			
:SYNC			
:CATalog?	CURRent ALL		Query only
:COMMent	<string>		
:COPY	<string>		
:DATA	<string>		
:DELeTe			
:FOUNd?			Query only
:MODE	MEAS SYNC		
:NAME	<string>		
:NSTate	2 4 8 16 32 64 128 256 512 1024		
:OFFSet	<numeric_value>	SYM	

:[SENSe<1|2>:]DDEMod:ECALc:OFFSet ON | OFF

This command controls the calculation of the error vector magnitude trace for Offset-QPSK only. It has no effect for all other modulations. It has no effect on results based on the MEAS or the REF signal.

ON: The error vector magnitude is calculated at the symbol instants of the I-part and the symbol instants of the Q-part of the Offset-QPSK signal.

In other words: The half symbol duration delay of the Q-part is compensated. In firmware versions prior to the introduction of this softkey, this method was always used for Offset-QPSK.

OFF: The error vector magnitude is calculated at the symbol instants of the I-part and the corresponding sample of the Q-part of the signal. But the latter is not a symbol instant.

In other words: The Offset-QPSK signal is treated like a QPSK signal for the error vector magnitude calculation, the Q-delay is not compensated.

Refer to the manual operation section for additional details

This command is only available for Offset-QPSK-Modulation.

Example: "DDEM:QPSK:FORM OFFS" 'Auswahl Offset-QPSK- Demodulation
"DDEM:ECAL:OFFS OFF" 'Deaktivierung von EVM CALC Offset

Characteristics: *RST value: ON
SCPI: device-specific

:[SENSe<1|2>:]DDEMod:EQUalize[:STATe] ON | OFF

This command switches the equalizer in or off.

Example: "DDEM:EQU ON" 'switches on equalizer

Characteristics: *RST value: OFF
SCPI: device-specific

:[SENSe<1|2>:]DDEMod:EQUalize:ADAPt ON | OFF

This command switches the learning phase of the equalizer on or off. Each sweep between commands `DDEM:EQU ON` and `DDEM:EQU OFF` are used for the calculation of the adaptive filter. This command is only available when the equalizer is switched on using command `DDEM:EQU ON`.

Example: "DDEM:EQU ON" "switches on equalizer
"DDEM:ADAP ON" 'switches on learning phase
"DDEM:ADAP OFF" 'switches off learning phase

Characteristics: *RST value: OFF
SCPI: device-specific

:[SENSe<1|2>:]DDEMod:EQUalize:CNVRRange 0 to 1

This command defines the speed of conversion of the adaptive filter .

Example: "DDEM:EQU:CNVR 0.1" 'sets the convergence to 1/10

Characteristics: *RST value: 1/100
SCPI: device-specific

:[SENSe<1|2>:]DDEMod:EQUalize:DELeTe <Equalizer_Name>

This command deletes a previously stored equalizer.

Example:	"DDEM:EQU ON"	'switches on equalizer
	"DDEM:ADAP ON"	'switches on learning phase
	"DDEM:ADAP OFF"	'switches off learning phase
	"DDEM:EQU:SAVE 'EQU_1'"	'stores the equalizers
	"DDEM:EQU:DEL 'EQU_1'"	'deletes the equalizer

Characteristics:	*RST value:	--
	SCPI:	device-specific

:[SENSe<1|2>:]DDEMod:EQUalize:LENGth 1 to 100

This command defines the length of the equalizer in terms of symbols. .

Example:	"DDEM:EQU:LEN 20"	'sets the resolution to 20 symbols
-----------------	-------------------	------------------------------------

Characteristics:	*RST value:	20
	SCPI:	device-specific

:[SENSe<1|2>:]DDEMod:EQUalize:LOAD <Equalizer_Name>

This command loads a previously stored equalizer. .

Example:	"DDEM:EQU:LOAD 'EQU_1'"	'loads the equalizer 'EQU_1'
-----------------	-------------------------	------------------------------

Characteristics:	*RST value:	--
	SCPI:	device-specific

:[SENSe<1|2>:]DDEMod:EQUalize:RESet

This command deletes the data of the currently selected equalizer. . After deletion, a new adaptive filter can be calculated using command EQU:ADAP ON.

Example:	"DDEM:EQU ON"	'switches on equalizer
	"DDEM:ADAP ON"	'switches on learning phase
	"DDEM:ADAP OFF"	'switches off learning phase
	"DDEM:EQU:RES"	'deletes the data of the equalizer

Characteristics:	*RST value:	--
	SCPI:	device-specific

:[SENSe<1|2>:]DDEMod:EQUalize:SAVE <Equalizer_Name>

This command loads an equalizer that was previously stored..

Example:	"DDEM:EQU ON"	'switches on equalizer
	"DDEM:ADAP ON"	'switches on learning phase
	"DDEM:ADAP OFF"	'switches off learning phase
	"DDEM:EQU:SAVE 'EQU_1'"	'stores the equalizers

Characteristics:	*RST value:	--
	SCPI:	device-specific

:[SENSe<1|2>:]DDEMod:EXPort:EQUalizer <name>,<path>

This command copies the selected internal equalizer file to the specified directory.

Parameter: <name>: Name of internal equalizer file
<path>: Path to which the internal files are copied

Example: "DDEM:EXP:EQU `EQUAL1`, 'A:\TEMP`"
'Equalizer EQUAL1 is copied to a:\temp

Characteristics: *RST value: -
SCPI: device-specific

The numeric suffix under SENSe<1|2> is irrelevant.

:[SENSe<1|2>:]DDEMod:EXPort:STANdard <name>,<path>

This command copies the selected internal modulation standard file to the specified directory. The associated patterns, mappings, filters and limit lines are saved along with the standard.

Parameter: <name>: Name of internal standard file. The file name is specified without a file extension. The file names of the predefined standards can be found using the SENS:DDEM:STAND:CAT? command.
<path>: Path to which the internal files are copied

Example: "DDEM:EXP:STAN `NADC_FWD`, 'A:\TEMP`" 'Standard NADC_FWD is copied to a:\temp

Characteristics: *RST value: -
SCPI: device-specific

The numeric suffix under SENSe<1|2> is irrelevant.

:[SENSe<1|2>:]DDEMod:EXPort:MAPPing <name>,<path>

This command copies the selected internal mappings file to the specified directory.

Parameter: <name>: Name of internal mappings file. The file name is specified without a file extension. The file names of the predefined standards can be found using the SENS:DDEM:STAND:CAT? command.
<path>: Path to which the internal files are copied

Example: "DDEM:EXP:MAPP `CDMA2K_FWD`, 'A:\TEMP`" 'Mapping CDMA2K_FWD is copied to a:\temp

Characteristics: *RST value: -
SCPI: device-specific

The numeric suffix under SENSe<1|2> is irrelevant.

:[SENSe<1|2>:]DDEMod:EXPort:PATTern <name>,<path>

This command copies the selected internal Pattern file to the specified directory.

Parameter: <name>: name of internal pattern file. The file name is specified without a file extension. The file names of the predefined standards can be found using the SENS:DDEM:STAND:CAT? command.
<path>: Path to which the internal files are copied

Example: "DDEM:EXP:PATT `GSM_AB0`, 'A:\TEMP`" 'Pattern GSM_AB0 is copied to a:\temp

Characteristics: *RST value: -
SCPI: device-specific

The numeric suffix under SENSe<1|2> is irrelevant.

:[SENSe<1|2>:]DDEMod:EXPort:FILTer <name>,<path>

This command copies the selected internal filter file to the specified directory.

Parameter: <name>: name of internal filter file. The file name is specified without a file extension. The file names of the predefined standards can be found using the `SENS:DDEM:STAND:CAT?` command.
<path>: Path to which the internal files are copied

Example: `"DDEM:EXP:FILT 'EDGE_ISI', 'A:\TEMP'"` 'Filter EDGE_ISI is copied to 'a:\temp

Characteristics: *RST value: -
SCPI: device-specific

The numeric suffix under SENSE<1|2> is irrelevant.

:[SENSe<1|2>:]DDEMod:FACToryALL | GSTandard | STANdard | MAPPing | PATTern | FILTer

The FACTORY DEFAULTSS softkey restores the factory settings of the parameters GENERIC STANDARDS, STANDARDS, MAPPINGS, PATTERN, FILTER and ALL for the R&S FSQ-K70/FSMR-B73/FSU-B73 option.

Example: `" :SENS:DDEM:FACT GST"`

Characteristics: *RST value: -
SCPI: device-specific

The numeric suffix under SENSE<1|2> is irrelevant.

:[SENSe<1|2>:]DDEMod:FILTer[:STATe] ON | OFF

This command defines whether the input signal that is used to evaluate the measurement is filtered. If the filter is switched off, the input signal is only corrected in frequency and time.

Example: `"DDEM:FILT OFF"` 'The input signal is not filtered.

Characteristics: *RST value: ON
SCPI: device-specific

:[SENSe<1|2>:]DDEMod:FILTer:ALPHa 0.2...1

This command determines the filter characteristic (ALPHA/BT). The resolution is 0.05.

Example: `"DDEM:FILT:ALPH 0.5"` 'Sets ALPHA/BT to 0.5

Characteristics: *RST value: Depends on the demodulation standard.
SCPI: device-specific

:[SENSe<1|2>:]DDEMod:FILTer:CATalog?

This command reads the names of all available filters.

The file names are output without file extension. Syntax of output format: filter_1,filter_2, ... ,filter_n

Example: `" :DDEM:FILT:CAT?"` 'Reads all filter names.

Characteristics: *RST value: -
SCPI: device-specific

:[SENSe<1|2>:]DDEMod:FILTer:MODulation <TX Filter>,<ISI Filter>, <MEAS Filter>

This command selects the TX, ISI and MEAS filter. The names of the filters correspond to the file names; a query of all available filters is possible by means of the "DDEM:FILT:CAT?" command.

Example: "DDEM:FILT:MOD `GAUSS`,`RC`,`RRC`" "GAUSS is selected for the TX filter, RC for the ISI filter and RRC for the Meas. filter.

Characteristics: *RST value: Depends on the demodulation standard.
SCPI: device-specific

:[SENSe<1|2>:]DDEMod:FORMat QPSK | PSK | MSK | QAM | FSK | VSB | UQAM

This command selects the digital demodulation mode.

Parameter:

QPSK	Quad Phase Shift Key
PSK	Phase Shift Key
MSK	Minimum Shift Key
QAM	Quadrature Amplitude Modulation
FSK	Frequency Shift Key
VSB	Vestigial Sideband
UQAM	User QAM, only available with user mapping files

Example: "DDEM:FORM QPSK" 'Switch QPSK demodulation on.

Characteristics: *RST value: Depends on the demodulation standard.
SCPI: device-specific

:[SENSe<1|2>:]DDEMod:FSK:NSTate 2 | 4

This command defines the specific demodulation mode for FSK.

Parameter:

2	2FSK
4	4FSK

Example: "DDEM:FORM FSK" 'Switch FSK demodulation on.
"DDEM:FSK:NST 2" 'Switch 2FSK demodulation on.

Characteristics: *RST value: -
SCPI: device-specific.

This command is only available for FSK demodulation.

:[SENSe<1|2>:]DDEMod:IMPort:EQUalizer <name>,<path>

This command copies the selected external equalizer file from the specified directory to the internal hard disk..

Parameter:

<name>:	Name of external equalizer file
<path>:	Path to which the internal files are copied

Example: "DDEM:IMP:EQU `EQUAL1`,`A:\TEMP`" 'Equalizer EQUAL1 which is located on a:\temp, is copied to the hard disk

Characteristics: *RST value: -
SCPI: device-specific

The numeric suffix under SENSe<1|2> is irrelevant.

:[SENSe<1|2>:]DDEMod:IMPorT:FILTer <name>,<path>

This command copies the selected external filter file from the specified directory to the internal hard disk.

Parameter: <name>: Name of external filter file
<path>: Path where the external files are located.

Example: "DDEM:IMP:FILT `EDGE_ISI`, 'A:\TEMP \" 'Filter EDGE_ISI which is 'located on a:\temp, 'is copied 'to the hard disk

Characteristics: *RST value: -
SCPI: device-specific

The numeric suffix under SENSE<1|2> is irrelevant.

:[SENSe<1|2>:]DDEMod:IMPorT:MAPPing <name>,<path>

This command copies the selected external mappings file from the specified directory to the internal hard disk.

Parameter: <name>: Name of external mapping file
<path>: Path where the external files are located.

Example: "DDEM:IMP:MAPP `CDMA2K_FWD`, 'A:\TEMP \" ' Mapping CDMA2K_FWD which is located on a:\temp, 'is copied to the hard disk

Characteristics: *RST value: -
SCPI: device-specific

The numeric suffix under SENSE<1|2> is irrelevant.

:[SENSe<1|2>:]DDEMod:IMPorT:PATTern <name>,<path>

This command copies the selected external pattern file from the specified directory to the internal hard disk.

Parameter: <name>: Name of external pattern file
<path>: Path where the external files are located.

Example: "DDEM:IMP:PATT `GSM_AB0`, 'A:\TEMP \" ' Pattern GSM_AB0' which is 'located on a:\temp, is copied 'to the hard disk

Characteristics: *RST value: -
SCPI: device-specific

The numeric suffix under SENSE<1|2> is irrelevant.

:[SENSe<1|2>:]DDEMod:IMPorT:STANdard <name>,<path>

This command copies the selected external modulation standard file from the specified directory to the internal hard disk. The associated patterns, mappings, filters and limit lines are saved along with the standard.

Parameter: <name>: Name of the external standard file. The file name is specified without a file extension.
<path>: Path where the external files are located.

Example: "DDEM:IMP:GST `DECT_USER`, 'A:\TEMP \" 'the file with the settings of the standard 'DECT_USER', 'which is located on a:\temp is copied to the hard disk

Characteristics: *RST value: -
SCPI: device-specific

The numeric suffix under SENSE<1|2> is irrelevant.

:[SENSe<1|2>:]DDEMod:MAPPING <file_name>

This command selects the mapping designated by <mapping_name> for the digital demodulation. The mapping describes the assignment of constellation points to symbols. The mapping names used here correspond to the mapping names given in the table of the predefined standard. (see "List of Predefined Standards and Standard Groups")

Parameter: <file_name>:= Name of mapping

Example: " :DDEM:MAPP 'GSM' " 'Set mapping GSM.

Characteristics: *RST value: -
SCPI: device-specific

:[SENSe<1|2>:]DDEMod:MAPPING:CATalog?

This command reads the names of all mappings stored on the hard disk. A mapping describes the assignment of constellation points to symbols.

The file names are output without file extension. Syntax of output format:
mapping_1,mapping_2, ... ,mapping_n

Example: " :DDEM:MAPP:CAT?" 'Reading all mapping file names.

Characteristics: *RST value: -
SCPI: device-specific

:[SENSe<1|2>:]DDEMod:MSK:FORMAT TYPE1 | TYPE2 | NORMal | DIFFerential

This command defines the specific demodulation mode for MSK.

Parameter: TYPE1, NORMal MSK
TYPE2, DIFFerential DMSK

Example: "DDEM:FORM MSK" 'Switch MSK demodulation on.
"DDEM:MSK:FORM TYPE2" 'Switch DMSK demodulation on.

Characteristics: *RST value: TYPE2 | DIFFerential
SCPI: device-specific

This command is only available for MSK demodulation.

:[SENSe<1|2>:]DDEMod:NORMalize ON | OFF

This command switches the compensation of the IQ offset on or off.

Example: "DDEM:NORM OFF" 'Switches the normalization off.

Characteristics: *RST value: ON
SCPI: device-specific

:[SENSe<1|2>:]DDEMod:PRATe 1 | 2 | 4 | 8 | 16

This command determines the number of points per symbol.

Example: "DDEM:PRAT 8" 'Sets 8 points per symbol.

Characteristics: *RST value: 4
SCPI: device-specific

:[SENSe<1|2>]:]DDEMod:PRESet[:STANdard]

<file_name> | APCO25C4FM | APCO25CQPSK | GSM | EDGE | FW3Gppcdma | RW3Gppcdma | FQCDma | F95Cdma | RQCDma | R95Cdma | CDMa2000 | F1CDma2000 | R1CDma2000 | FNADc | RNADc | PDCDown | PDCup | PHS | TETRa | DECT | DCS1800 | PCS1900

This command selects an automatic setting of all modulation parameters according to a standardized transmission method or a user-defined transmission method. The standardized transmission methods are available in the unit (predefined standard).

The transmission methods are set via a file name without extension (string data with quotation marks). Some predefined transmission methods can be set via a value also (character data without quotation marks) for reasons of compatibility with former instrument models.

Example: "DDEM:PRESet TETR" 'Switches the predefined digital 'standard Tetra on.
 "DDEM:PRESet 'USER_GSM'" 'Switches the userdefined digital 'standard 'USER_GSM' on.

Characteristics: *RST value: GSM
 SCPI: device-specific

The following predefined standards are available:

File name	Description	Value
GSM_NB	GSM, Normal Burst	GSM
GSM_SB	GSM, Synchronization Burst	-
GSM_FB	GSM, Frequency Correction Burst	-
GSM_AB	GSM, Access Burst	-
EDGE_NB	Edge	EDGE
3G_WCDMA_FWD	3GPP Wcdma forward	FW3Gppcdma
3G_WCDMA_REV	3GPP Wcdma reverse	RW3Gppcdma
CDMAONE_FWD	Cdma One forward according to standard IS95	FQCDma
CDMAONE_REV	Cdma One reverse according to standard IS95	RQCDma
CDMA2K_1X_FWD	Cdma 2000 forward, spreading rate 1	F1CDma2000
CDMA2K_1X_REV	Cdma 2000 reverse, spreading rate 1	R1CDma2000
IS95_FWD	IS95 forward according to standard IS95	F95Cdma
IS95_REV	IS95 reverse according to standard IS95	R95Cdma
NADC_FWD	Nadc forward	FNADc
NADC_REV	Nadc reverse	RNADc
PDC_DOWN	Pdc down	PDCDown
PDC_UP	Pdc up	PDCup
PHS_COMM	PHS (data burst)	PHS
PHS_CTRL	PHS (control burst)	-
TETRA_NDDOWN	Tetra (data burst)	TETRa
TETRA_NCDOWN	Tetra (control burst)	-
DECT_FP	DECT	DECT
GSM_NB	DCS 1800	DCS1800
GSM_NB	PCS 1900	PCS1900
BLUETOOTH_DH1	Bluetooth, High data rate, slot length 1	-
BLUETOOTH_DH3	Bluetooth, High data rate, slot length 3	-
BLUETOOTH_DH5	Bluetooth, High data rate, slot length 5	-

:[SENSe<1|2>:]DDEMod:PRESet:RLEVel

This command initiates automatic setting of the RF attenuation and IF gain to the level of the applied signal.

Note: *The following command must be synchronized to the end of the autorange process by means of *WAI, *OPC oder *OPC?, because otherwise the autorange process will be stopped.*

The numeric suffix <1|2> has no meaning with this command.

Example: ":DDEM:PRESet:RLEV;*WAI" 'performs automatic level setting

Characteristics: *RST value: -
SCPI: device-specific

:[SENSe<1|2>:]DDEMod:PSK:FORMat NORMal | DIFFerential | N3Pi8

This command defines the specific demodulation mode for PSK. The specific demodulation mode (DDEM:PSK:NST) must be set to 8.

The following PSK demodulation modes are possible:

DDEMod:PSK:NSTate	DDEMod:PSK:FORMat	Modulation Mode
2	any	BPSK
8	NORMal	8PSK
8	DIFFerential	D8PSK
8	N3Pi8	$3\pi/8$ -8PSK (EDGE)

Example: "DDEM:FORM PSK" 'Switch PSK demodulation on.
 "DDEMod:PSK:NST 8" 'Switch 8PSK demodulation on.
 "DDEM:PSK:FORM DIFF" 'Switch D8PSK demodulation on.

Characteristics: *RST value: -
SCPI: device-specific

This command is only available for PSK demodulation.

:[SENSe<1|2>:]DDEMod:PSK:NSTate 2 | 8

This command defines the specific demodulation mode for PSK. The following PSK demodulation modes are possible:

DDEMod:PSK:NSTate	DDEMod:PSK:FORMat	Modulation Mode
2	any	BPSK
8	NORMal	8PSK
8	DIFFerential	D8PSK
8	N3Pi8	$3\pi/8$ -8PSK (EDGE)

Example: "DDEM:FORM PSK" 'Switch PSK demodulation on.
 "DDEM:PSK:FORM DIFF" 'Switch D8PSK demodulation on.
 "DDEMod:PSK:NST 8" 'Switch 8PSK demodulation on.

Characteristics: *RST value: -
SCPI: device-specific

This command is only available for PSK demodulation.

:[SENSe<1|2>:]DDEMod:QAM:NSTate 16 | 32 | 64 | 128 | 256

This command defines the specific demodulation mode for QAM.

Parameter:

16	16 QAM
32	32 QAM
64	64 QAM
128	128 QAM
256	256 QAM

Example: "DDEM:FORM QAM" 'Switches QAM demodulation on.
"DDEM:QAM:NST 64" 'Switches 64QAM demodulation on.

Characteristics: *RST value: 16
SCPI: device-specific.

This command is only available for QAM demodulation.

:[SENSe<1|2>:]DDEMod:QAM:FORMat NORMal | DIFFerential

This command defines the specific demodulation mode for QAM.

Parameter:

NORMal	QAM
DIFFerential	DQAM

Example: "DDEM:FORM QAM" 'Switches QAM demodulation on.
"DDEM:QAM:FORM DQAM" 'Switches differential DQAM demodulation on.

Characteristics: *RST value: -
SCPI: device-specific

This command is only available for QAM demodulation.

:[SENSe<1|2>:]DDEMod:QPSK:FORMat NORMal | DIFFerential | OFFSet | DPI4

This command defines the specific demodulation mode for QPSK.

Parameter:

NORMal	QPSK
DIFFerential	DQPSK
OFFSet	OQPSK
DPI4	$\pi/4$ DQPSK

Example: "DDEM:FORM QPSK" 'Switch QPSK demodulation on.
"DDEM:QPSK:FORM DPI4" 'Switch $\pi/4$ DQPSK demodulation on.

Characteristics: *RST value: -
SCPI: device-specific

This command is only available for QPSK demodulation.

:[SENSe<1|2>:]DDEMod:RLENgth <numeric_value>

This command defines the recording length for further processing, e.g. for burst search. The RLENgth is given in time (S) or symbols (SYM).

The value range for SYM is 100 [sym] to 8000000/pointspersymbol [sym].

Example: "DDEM:RLEN 1000SYM" 'Sets a recording length of 1000 symbols.

Characteristics: *RST value: Depends on the demodulation standard.
SCPI: device-specific

:[SENSe<1|2>:]DDEMod:RLENgth:AUTO ON | OFF

This command switches the automatic adaptation of the recording length on or off. The automatic adaptation is performed so that a sufficient recording length is set as a function of result length, burst and pattern search and network-specific characteristics (e.g. burst and frame structure).

Example: "DDEM:RLEN:AUTO OFF" Do not set RLENgth automatically.

Characteristics: *RST value: ON
SCPI: device-specific

:[SENSe<1|2>:]DDEMod:SBANd NORMAl | INVerse

This command selects the sideband for the demodulation.

Parameter: NORMAl Normal (non-inverted) position
INVerse inverted position

Example: "DDEM:SBAN INV" 'Selects the inverted position.

Characteristics: *RST value: NORMAl
SCPI: device-specific

:[SENSe<1|2>:]DDEMod:SEARch:BURSt:GLENgth[:MINimum] <numeric_value>

This command defines the minimum time between two bursts. A minimum time with decreased level must occur between two bursts. A new burst is recognized only after this time. The default unit is a symbol. The value can also be given in seconds..

Example: "DDEM:SEAR:BURS:GLEN 3US" 'At least 3 us must elapse
'between two bursts so that the
'second burst can be
'recognized as a separate burst.

Characteristics: *RST value: 2 symbols for PSK, GSM, EDGE
1 symbol for FSK, MSK
4 symbols for QAM
SCPI: device-specific

:[SENSe<1|2>:]DDEMod:SEARch:BURSt:HYSTeresis[:LEVel] <numeric_value>

This command defines the trigger hysteresis to ensure that the end of the burst is reliably detected.

Example: "DDEM:SEAR:BURS:HYST:AUTO OFF" 'Use manual value
"DDEM:SEAR:BURS:HYST 12DB" 'Set 12 dB hysteresis

Characteristics: *RST value: 5 dB for QAM, otherwise 9 dB
SCPI: device-specific

:[SENSe<1|2>]:DDEMod:SEARch:BURSt:LENGth[:MINimum] <numeric_value>

This command defines the minimum length of a burst. Only those bursts will be recognized that exceed this length. The default unit is a symbol. The value can also be given in seconds .

Example: "DDEM:SEAR:BURS:LENG 140US" 'The minimum burst length is 140 us.

Characteristics: *RST value: 16 symbols for PSK, FSK, MSK, QAM
130 symbols for GSM, EDGE
SCPI: device-specific

:[SENSe<1|2>]:DDEMod:SEARch:BURSt:LENGth:MAXimum <numeric_value>

This command defines the maximum length of a burst. Only those bursts will be recognized that fall below this length. The default unit is a symbol. The value can also be given in seconds.

Example: "DDEM:SEAR:BURS:LENG:MAX 156US" 'The maximum burst length is 156 μ s.

Characteristics: *RST value: 6400 symbols for PSK, FSK, MSK, QAM
160 symbols for GSM, EDGE
SCPI: device-specific

:[SENSe<1|2>]:DDEMod:SEARch:BURSt:MODE MEAS | BURSt

This command sets the vector analyzer so that a measurement is performed only if a burst is found (BURSt).

The command is available only if the burst search is activated with the DDEM:SEARch:BURSt:STATe = ON command.

Example: "DDEM:SEAR:BURS:MODE BURSt" 'Sweep only if burst is found

Characteristics: *RST value: MEAS
SCPI: device-specific

:[SENSe<1|2>]:DDEMod:SEARch:BURSt:SKIP:FALLing <numeric_value>

This command defines the length of the falling burst edge which is not considered when evaluating the result. The default unit is a symbol. The value can also be given in seconds.

Example: "DDEM:SEAR:BURS:SKIP:FALL 5US" '5 us of the rising burst edge are not considered

Characteristics: *RST value: 1 symbol for PSK, FSK
4 symbols for MSK
2 symbols for QAM
5 symbols for GSM, EDGE
SCPI: device-specific

:[SENSe<1|2>]:DDEMod:SEARch:BURSt:SKIP:RISing <numeric_value>

This command defines the length of the rising burst edge which was not considered when evaluating the result. The default unit is a symbol. The value can also be given in seconds ..

Example: "DDEM:SEAR:BURS:SKIP:RIS 5US" '5 us of the rising burst edge are not considered

Characteristics: *RST value: 1 symbol for PSK, FSK
4 symbols for MSK
2 symbols for QAM
5 symbols for GSM, EDGE
SCPI: device-specific

:[SENSe<1|2>:]DDEMod:SEARch:BURSt[:STATe] ON | OFF

This command switches the search for a signal burst on or off.

Example: "DDEM:SEAR:BURS OFF" 'Switch burst search off.

Characteristics: *RST value: ON
SCPI: device-specific

:[SENSe<1|2>:]DDEMod:SEARch:BURSt:THReshold:AUTO ON | OFF

This command defines which value is to be used as the threshold. ON corresponds to a relative threshold value defined by the standard. The value entered via DDEM:SEAR:BURS:HYST is used as the threshold when OFF is selected.

Example: "DDEM:SEAR:BURS:THR:AUTO OFF" 'Use manual value for burst
'search

Characteristics: *RST value: ON
SCPI: device-specific

:[SENSe<1|2>:]DDEMod:SEARch:BURSt:THReshold[:LEVe] <numeric_value>

This command defines the threshold for the burst search. The value can either be given relative to the reference level (in dB) or as absolute value (in dBm). With Auto (ddem:sear:burs:thr:auto on) selected, a query or setting is not possible and an execution error is returned.

Example: "DDEM:SEAR:BURS:THR -20DB" '-20 db difference during burst
'search.

Characteristics: *RST value: 0
SCPI: device-specific

:[SENSe<1|2>:]DDEMod:SEARch:BURSt:THReshold:MODE RELative | ABSolute

This command defines whether the threshold is absolute or relative (to the reference level).

Example: "DDEM:SEAR:BURS:THR:MODE REL" 'Threshold is relative

Characteristics: *RST value: REL
SCPI: device-specific

:[SENSe<1|2>:]DDEMod:SEARch:MBURst:CAPTure:AUTO ON | OFF

This command defines the mode for writing to the capture RAM. If the state is ON, a new data capture operation will be initiated when the end of the capture RAM is reached (and DDEM:SEAR:MBUR:FIND:NEXT occurs again). This command is available only in single sweep mode.

Example: "DDEM:SEAR:MBUR ON" 'switch on multi burst search
"DDEM:SEAR:MBUR:CAP:AUTO OFF" 'do not overwrite capture RAM

Characteristics: *RST value: ON
SCPI: device-specific

:[SENSe<1|2>:]DDEMod:SEARch:MBURst:FIND:NEXt

This command searches the next burst/sync pattern in the Capture Ram.

Example:

"DDEM:SEAR:MBUR ON"	'switch on multi burst search
"DDEM:SEAR:BURS ON"	'switch on burst search
"DDEM:SEAR:MBUR:FIND:NEXt"	'find next burst

Characteristics: *RST value: --
SCPI: device-specific

:[SENSe<1|2>:]DDEMod:SEARch:MBURst:FIND:FIRSt

This command searches the first burst/sync pattern in the Capture Ram.

Example:

"DDEM:SEAR:MBUR ON"	'switch on multi burst search
"DDEM:SEAR:BURS ON"	'switch on burst search
"DDEM:SEAR:MBUR:FIND:FIRSt"	'find first burst

Characteristics: *RST value: --
SCPI: device-specific

:[SENSe<1|2>:]DDEMod:SEARch:MBURst:FIND:STARt

This command searches for the first burst/sync pattern that occurs starting at the position that was defined via the command DDEM:SEAR:MBUR:STAR. This is the position starting at which the signal is demodulated in the capture RAM.

Example:

"DDEM:SEAR:MBUR ON"	'switch on multi burst search
"DDEM:SEAR:SYNC ON"	'switch on pattern search
"DDEM:SEAR:MBUR:STAR 500SYM"	'Start bei 500 Symbols
"DDEM:SEAR:MBUR:FIND:STAR"	'find first sync patt starting at start pos

Characteristics: *RST value: --
SCPI: device-specific

:[SENSe<1|2>:]DDEMod:SEARch:MBURst:LENGth 10...32000

This command defines the length of the visible range in the Magnitude Capture display..

Example:

"DDEM:SEAR:MBUR ON"	'switch on multi burst search
"DDEM:SEAR:BURS ON"	'switch on burst search
"DDEM:SEAR:MBUR:STAR 500SYM"	'start of demodulation
"DDEM:SEAR:MBUR:LENG 1000SYM"	'length of demodulation

Characteristics: *RST value: Record Length, depends on standard
SCPI: device-specific

:[SENSe<1|2>:]DDEMod:SEARch:MBURst:STARt <numeric_value>

This command defines the start of the visible range in the Magnitude Capture display.

Example:

"DDEM:SEAR:MBUR ON"	'switch on multi burst search
"DDEM:SEAR:BURS ON"	'switch on burst search
"DDEM:SEAR:MBUR:STAR 500SYM"	'start at symbol 500

Characteristics: *RST value: 0
SCPI: device-specific

:[SENSe<1|2>:]DDEMod:SEARch:MBURst[:STATe] ON | OFF

This command sets the multi-burst search. First, a large amount of data is captured in the capture RAM. This data can then be demodulated and measured. The visible area in the magnitude capture displays is defined with the commands `DDEM:SEAR:MBUR:STAR` and `DDEM:SEAR:MBUR:LENG`. The commands `DDEM:SEAR:BURS` and `DDEM:SEAR:SYNC` are used to define whether to search for bursts or sync patterns (commands `DDEM:SEAR:MBUR:FIND:FIRS`, `DDEM:SEAR:MBUR:FIND:NEXT`, `DDEM:SEAR:MBUR:FIND:STAR`).

Example: `"DDEM:SEAR:MBUR ON"` "Switch on multi burst search"

Characteristics: *RST value: ON
SCPI: device-specific

:[SENSe<1|2>:]DDEMod:SEARch:SYNC:CATalog? CURRent | ALL

This command reads the names of all patterns stored on the hard disk. Either all patterns are read out or only those patterns that belong to the current standard.

Parameter: CURRent Reading out patterns that belong to the current standard
 ALL Reading out all patterns available on hard disk

The file names are output without file extension. Syntax of output format:
pattern_1,pattern_2, ... ,pattern_n

Example: `"DDEM:PRES TETR"` 'Digital standard Tetra
 `"DDEM:SEAR:SYNC:PATT:ADD "PGSM_1"`
 'Add PGSM_1 to standard.
 `"DDEM:SEAR:SYNC:CAT? CURR"` 'Read out all patterns
 'that belong to the standard.

Characteristics: *RST value: -
SCPI: device-specific

:[SENSe<1|2>:]DDEMod:SEARch:SYNC:COMMeNt <string>

This command defines a comment to a sync pattern. The pattern must have been selected before with the `DDEM:SEARch:SYNC:NAME` command.

Example: `" :DDEM:SEAR:SYNC:NAME "GSM_1""` 'Name of pattern.
 `" :DDEM:SEAR:SYNC:DATA "0001 0000 0000 0001""`
 'Data of pattern 1001.
 `" :DDEM:SEAR:SYNC:COMM 'PATTERN FOR PPSK' "` 'Comment.

Characteristics: *RST value: ""
SCPI: device-specific

:[SENSe<1|2>:]DDEMod:SEARch:SYNC:COpy <string>

This command copies a pattern file. The pattern to be copied must have been selected before with the `DDEM:SEARch:SYNC:NAME` command.

Note: *In manual operation, a pattern can be copied in the editor by storing it under a new name.*

Example: `" :DDEM:SEAR:SYNC:NAME "GSM_1""` 'Name of pattern.
 `" :DDEM:SEAR:SYNC:COpy "GSM_2""` 'Copy GSM_1 to GSM_2.

Characteristics: *RST value: ""
SCPI: device-specific

:[SENSe<1|2>:]DDEMod:SEARch:SYNC:MODE MEAS | SYNC

This command sets the vector analyzer so that the measurement is performed only if the measurement was synchronous to the selected sync pattern (SYNC).

The measured values are displayed and considered in the error evaluation only if the set sync pattern was found. Bursts with a wrong sync pattern (sync not found) are ignored. If an invalid or no sync pattern is found, the measurement waits and resumes running only when a valid sync pattern is found.

The command is available only if the sync sequence search is activated with the DDEM:SEARch:BURSt:STATe = ON command.

With MEAS selected, the measurement is performed independent of successful synchronization.

Example: ":DDEM:SEAR:SYNC:MODE SYNC" 'The measurement is
'performed only with successful
'synchronization.'

Characteristics: *RST value: MEAS
SCPI: device-specific

:[SENSe<1|2>:]DDEMod:SEARch:SYNC:NAME <string>

This command selects a sync pattern for editing or for a new entry.

Example: ":DDEM:SEAR:SYNC:NAME 'PATT_1'" 'Selects the pattern
'"Patt_1".'

Characteristics: *RST value: ""
SCPI: device-specific

:[SENSe<1|2>:]DDEMod:SEARch:SYNC:NState 2 | 4 | 8 | 16 | 32 | 64 | 128 | 256 | 512 | 1024

This command selects the degree of modulation (number of permitted states). The pattern must have been selected before with the DDEM:SEARch:SYNC:NAME command.

Parameter: MSK 2
 PSK 2, 4, 8
 QAM 16..1024
 FSK 2, 4

Example: ":DDEM:SEAR:SYNC:NAME "GSM_1"" Selects the "GSM_1" pattern.
 ":DDEM:SEAR:SYNC:DATA "1001"" 'Enters 1001 as data.
 ":DDEM:SEAR:SYNC:NST 4" 'Sets the degree of modulation.

Characteristics: *RST value: --
SCPI: device-specific

:[SENSe<1|2>:]DDEMod:SEARch:SYNC:PATtern:ADD <string>

This command adds a pattern to the current standard. With the DDEM:SEAR:SEL command, only those patterns can be selected which belong to the current standard.

Example: "DDEM:PREs TETRa" "Add digital standard Tetra
 "DDEM:SEAR:SYNC:PATT:ADD "PGSM_1"'PGSM_1 to the 'standard.

Characteristics: *RST value: --
SCPI: device-specific

This command is an event and thus has no *RST value and no query.

:[SENSe<1|2>:]DDEMod:SEARch:SYNC:PATtern:REMOve <string> | ALL

This command deletes one or all patterns from the current standard.

Example: "DDEM:PRES TETRa" "Select digital standard Tetra.
"DDEM:SEAR:SYNC:PATT:REM ALL" 'Remove all patterns from the
'Tetra standard.

Characteristics: *RST value: --
SCPI: device-specific

This command is an event and thus has no *RST value and no query.

:[SENSe<1|2>:]DDEMod:SEARch:SYNC:SElect <string>,<string>,...

This command selects a predefined sync pattern file. Up to 16 sync pattern files may be given.

Example: "DDEM:SEAR:SYNC:SEL "PAT_GSM_1", "PAT_GSM_5""

Characteristics: *RST value: ""
SCPI: device-specific

:[SENSe<1|2>:]DDEMod:SEARch:SYNC[:STATe] ON | OFF

This command switches the search for a sync sequence on or off.

Example: "DDEM:SEAR:SYNC ON" 'Switches the sync search on.

Characteristics: *RST value: OFF
SCPI: device-specific

:[SENSe<1|2>:]DDEMod:SEARch:SYNC:TEXT <string>

This command defines a text to explain the pattern. The text is displayed only in the selection menu (manual control). This text is supposed to be short and concise. Detailed information about the pattern is given in the comment.

Example: " :DDEM:SEAR:SYNC:NAME 'GSM_1' " 'Selects the "GSM_1" pattern.
" :DDEM:SEAR:SYNC:DATA "1001" " 'Enter pattern 1001.
" :DDEM:SEAR:SYNC:TEXT "TEST S25" " 'Enter text for the "GSM_1"
pattern.

Characteristics: *RST value: ""
SCPI: device-specific

:[SENSe<1|2>:]DDEMod:SRATe 100 Hz to max

This command defines the symbol rate.

Example: "DDEM:SRAT 18kHz" 'Sets the symbol rate to 18 kHz.

Characteristics: *RST value: Depends on the demodulation standard.
SCPI: device-specific

:[SENSe<1|2>:]DDEMod:STANdard:CATalog?

This command reads the names of all digital standards.

The file names are output without file extension. Syntax of output format:
standard_1,standard_2, ... ,standard_n

Example: " :DDEM:STAN:CAT?" 'Reads all digital standards.

Characteristics: *RST value: -
SCPI: device-specific

:[SENSe<1|2>:]DDEMod:STANdard:COMMeNt <string>

This command enters the comment for a new standard. The comment is stored with the standard and is only displayed in the selection menu (manual operation). When remote control is used, the string is deleted after the standard has been stored, allowing a new comment to be entered for the next standard. In this case a blank string is returned when a query is made.

Example: "DDEM:STAN:GRO `GSM`" 'Selects group GSM for the new
'standard
"DDEM:STAN:COMM `FOR TEST`" 'Enters the comment
"DDEM:STAN:PREF `GSM_NB`" 'Enters the prefix of the Sync
'patterns
"DDEM:STAN:SAVE `XG_2000`" 'Stores the current settings
'including group, comment and
'prefix as 'XG_2000 standard.
'The strings of the above
'commands are cleared.

Characteristics: *RST value: "
SCPI: device-specific

:[SENSe<1|2>:]DDEMod:STANdard:DELeTe <file_name>

This command deletes the selected digital standard. The file names of the predefined standards can be determined with the query SENS:DDEM:STAND:CAT? (see below).

Note: *The standards predefined by Rohde & Schwarz can be restored using the FACTORY DEFAULTS softkey (HOME VSA menu).*

Example: "DDEM:STAN:DEL `STD_GSM`" 'Deletes the STD_GSM standard.

Characteristics: *RST value: "
SCPI: device-specific

:[SENSe<1|2>:]DDEMod:STANdard:GROup <string>

This command enters the group for a new standard. The group is stored with the standard and is only displayed in the selection menu (manual operation). When remote control is used, the string is deleted after the standard has been stored, allowing a new group to be entered for the next standard. In this case a blank string is returned when a query is made.

Example:

DDEM:STAN:GRO 'GSM '	'Selects group GSM for the new standard
"DDEM:STAN:COMM 'FOR TEST '"	'Enters the comment "DDEM:STAN:PREF
"DDEM:STAN:PREF 'GSM_NB '"	'Enters the prefix of the Sync patterns
"DDEM:STAN:SAVE 'XG_2000 '"	'Stores the current settings
	'including group, comment and
	'prefix as 'XG_2000 standard.
	'The strings of the above
	'commands are cleared.

Characteristics: *RST value: ""
SCPI: device-specific

:[SENSe<1|2>:]DDEMod:STANdard:PREfix <string>

This command defines the prefix of the sync pattern for a standard. When a sync pattern for the standard is selected later, the patterns containing this string at the start are offered with priority in the selection table (only relevant to manual operation). When remote control is used, the string is deleted after the standard has been stored, allowing a new prefix to be entered for the next standard. In this case a blank string is returned when a query is made.

Example:

"DDEM:STAN:GRO 'GSM '	'Selects group GSM for the new standard
"DDEM:STAN:COMM 'FOR TEST '"	'Enters the comment for the new standard
"DDEM:STAN:PREF 'GSM_NB '"	'Enters the prefix of the Sync patterns
"DDEM:STAN:SAVE 'XG_2000 '"	'Stores the current settings including group,
	'comment and prefix as 'XG_2000 standard.
	'The strings of the above commands are
	'cleared.

Characteristics: *RST value: ""
SCPI: device-specific

:[SENSe<1|2>:]DDEMod:STANdard:PREset

This command restores the default settings of the currently selected standard.

Example: "DDEM:STAN:PRE" 'Restores the default settings of the currently selected standard.

Characteristics: *RST value: --
SCPI: device-specific

This command is an event and thus has no *RST value and no query.

:[SENSe<1|2>:]DDEMod:STANdard:SAVE <file_name>

This command stores the current settings of the vector signal analysis as a new user-defined digital standard. If the name of the digital standard is already in use, an error message is output and a new name has to be selected. It is recommended to define a group, a comment and a prefix before storing the standard (see example)

Example:

DDEM:STAN:GRO 'GSM'	'Selects group GSM for the new standard
"DDEM:STAN:COMM 'FOR TEST'"	'Enters the comment for the new standard
"DDEM:STAN:PREF 'GSM_NB'"	'Enters the prefix of the Sync patterns
"DDEM:STAN:SAVE 'XG_2000'"	'Stores the current settings including group, comment and prefix as 'XG_2000 standard. The strings of the above commands are cleared.

Characteristics: *RST value: ""
SCPI: device-specific

:[SENSe<1|2>:]DDEMod:STANdard:SYNC:OFFSet <numeric_value>

This command defines the number of bits to be reoffset of the pattern in symbols with reference to the start of the burst.

Example: "DDEM:STAN:SYNC:OFFS10" 'The sync offset comprises 10 symbols before the start of the burst.

Characteristics: *RST value: 0
SCPI: device-specific

:[SENSe<1|2>:]DDEMod:TIME 10...8000 Symbole

The command determines the number of displayed symbols (result length).

Example: "DDEM:TIME 80" 'Sets result length to 80 symbols.

Characteristics: *RST value: Depends on the demodulation standard.
SCPI: device-specific

:[SENSe<1|2>:]DDEMod:UQAM:FORMat'<UQAM_Mapping>'

This command selects the specific demodulation mapping for UQAM .

Parameter: <UQAM_Mapping> 'Mapping name

Example:

"DDEM:FORM UQAM"	'Switch UQAM demodulation on.
"DDEM:UQAM:FORM 'UQAM_demod_mode'"	'Select the UQAM demodulation mode
"DDEM:MAPP 'UQAM_mapping_file'"	'Select the User QAM mapping if needed (s. above)

Characteristics: *RST value: -
SCPI: device-specific

This command is only available for UQAM demodulation. Related mapping files have to be imported.

:[SENSe<1|2>:]DDEMod:UQAM:NSTate?

This command returns the specific modulation level for UQAM. .

Example: "DDEM:FORM UQAM" 'Switch User QAM demodulation on.
 "DDEM:UQAM:FORM 'special'" 'Selects user mapping 'special'.
 "DDEM: UQAM:NST?" 'returns the modulation level.

Characteristics: *RST value: -
 SCPI: device-specific.

This command is only available for UQAM demodulation.

:[SENSe<1|2>:]DDEMod:VSB:NSTate 8

The command determines the specific demodulation type for VSB. The numeric suffix <1|2> has no meaning with this command.

Parameter: 8 8VSB

Example: "DDEM:FORM VSB" 'switch on VSB demodulation
 "DDEM:VSB:NST 8" 'select 8VSB demodulation

Characteristics: *RST value: -
 SCPI: device-specific

This command is only available for VSB demodulation.

:[SENSe<1|2>:]DDEMod:WBANd[:STATe] ON | OFF

This command switches the use of option "Bandwidth Extension R&S FSQ-B72" signal path below 100 MHz on or off. Option "Bandwidth Extension R&S FSQ-B72" is automatically activated when using sample rates above 100 MHz (= symbol rate * points/symbol). If the state is set to ON the B72 signal path is also used below 100MHz. The command is available if the symbol rate is ≥ 5.1 MHz (at 4 points/symbol). Reducing the symbol rate below 5.1 MHz will automatically switch off this function.

Example: "DDEM:WBAN ON" 'Switches the use of B72 signal path below
 100 MHz on.

Characteristics: *RST value: OFF
 SCPI: device-specific

This command is only available for R&S FSQ and if R&S FSQ-B72 is installed.

SENSe:FREQuency Subsystem

The SENSe:FREQuency subsystem controls the frequency axis of the active measurement window. The measurement window is selected via SENSe1 (SCREEN A) and SENSe2 (SCREEN B).

COMMAND	PARAMETER	UNIT	COMMENT
[SENSe<1 2>] :FREQuency :CENTer :STEP :AUTO	<Boolean>		

:[SENSe<1|2>:]FREQuency:CENTer:STEP:AUTO ON | OFF

This command links the step width to the current standard (ON) or sets the step width entered with the `FREQ:CENT:STEP` command (OFF).

Example: "`FREQ:CENT:STEP:AUTO ON`" 'Activates the linking of the step width to the current standard.'

Characteristics: *RST value: ON
 SCPI: device-specific

TRACe Subsystem

The TRACe subsystem controls access to the instrument's internal trace memory.

The numeric suffix is used in TRACe to make the distinction between the two measurement windows SCREEN A and SCREEN B:

TRACe1 = Screen A
TRACe2 = Screen B.

In Vector Analyzer mode, the numeric suffixes 3 and 4 are used in addition to make the distinction between the two measurement windows SCREEN C and SCREEN D in SPLIT SCREEN mode:

TRACe3 = Screen C
TRACe4 = Screen D.

For commands without suffix, screen A is selected automatically.

Full Screen The settings are valid for the measurement window selected with the numeric suffix. They become effective as soon as the corresponding measurement window has been selected as active measurement window using the command `DISPlay[:WINDow<1|2>]:SElect`. Triggering measurements and querying measured values is possible only in the active measurement window.

Split Screen The settings are valid for the measurement window selected by means of the numeric suffix and become effective immediately.

COMMAND	PARAMETERS	UNIT	COMMENT
TRACe<1 2> [:DATA]	TRACE1 TRACE2 TRACE3 TRACE4 <block> <numeric_value>...	-	

TRACe<1|2>[:DATA] TRACE1|TRACE2|TRACE3 | TRACE4 , <block> | <numeric_value>

This command transfers trace data from the control computer to the instrument, the query reads trace data out of the instrument. The associated measurement window is selected with the numeric suffix of TRACe<1|2>.

Number and format of the measurement values for operating mode Vector Signal Analysis

Cartesian diagrams

In all cartesian diagrams (Magnitude, Phase, Frequency, Real/Imag, Eye) only the Y-values are transferred. The number of Y-values is the product of RESULT LENGTH and POINTS PER SYMBOL. The X-value related to the first Y-value is queried with command

`DISP:TRAC:X:START?`.

The test data are transferred in the unit selected for display. FORMAT REAL,32 is to be used for binary transmission.

Note: *In the case of the eye pattern, results are simply superimposed in the display, ie the EYE representation is the same as the REAL/IMAG representation.*

Polar diagrams

In the polar diagrams (Polar Constellation, Polar Vector) the real and the imaginary component are transferred as a pair for each result. The number of value pairs is the product of RESULT LENGTH and POINTS PER SYMBOL for POLAR VECTOR, and the RESULT LENGTH for POLAR CONSTELLATION.

FORMAT REAL,32 is to be used for binary transmission.

Symbols & Modulation Accuracy**Symbol Table:**

The displayed symbols can be read out as TRACE1. The data is transferred in symbols in UINT16 format. The value range depends on the specific demodulation mode (for 8PSK the value range for a symbol is 0..7)

Modulation Accuracy:

The symbol accuracy is read out as TRACE2.

Modulation type FSK, number of measurement values for FSK: 42, format:

<1: FSK Dev Error (Result)>,<2: FSK Dev Error (Peak)>,
 <3: FSK Dev Error (atSym)>,<4: FSK Dev Error (Rms)>,
 <5: FSK Dev Error (Avg)>,<6: FSK Dev Error (StdDev)>,
 <7: FSK Dev Error (Total Peak)>,<8: FSK Meas Dev (Result)>,
 <9: FSK Meas Dev (Rms)>,<10: FSK Meas Dev (Avg)>,
 <11: FSK Meas Dev (StdDev)>,<12: FSK Rev Dev (Result)>,
 <13: Carrier Freq Err (Result)>,<14: Carrier Freq Err (Rms)>,
 <15: Carrier Freq Err (Avg)>,<16: Carrier Freq Err (StdDev)>,
 <17: Carrier Freq Drift (Result)>,<18: Carrier Freq Drift (Rms)>,
 <19: Carrier Freq Drift (Avg)>,<20: Carrier Freq Drift (StdDev)>,
 <21: Mag Err (Result)>,<22: Mag Err (Peak)>,
 <23: Mag Err (atSym)>,<24: Mag Err (Rms)>,
 <25: Mag Err (Avg)>,<26: Mag Err (StdDev)>,
 <27: Mag Err (Total Peak)>,<28: Ampt Droop (Result)>,
 <29: Ampt Droop (Rms)>,<30: Ampt Droop (Avg)>,
 <31: Ampt Droop (StdDev)>,<32: Mean Power (Result)>,
 <33: Mean Power (Peak)>,<34: Mean Power (atSym)>,
 <35: Mean Power (Rms)>,<36: Mean Power (Avg)>,
 <37: Mean Power (StdDev)>,<38: Mean Power (Total Peak)>,
 <39: Trigger to Sync (Result)>,<40: Trigger to Sync (Rms)>,
 <41: Trigger to Sync (Avg)>,<42: Trigger to Sync (StdDev)>

Modulation type VSB, number of measurement values: 57

<1: EVM (Result)>,<2: EVM (Peak)>,
 <3: EVM (atSym)>,<4: EVM (Rms)>,
 <5: EVM (Avg)>,<6: EVM (StdDev)>,
 <7: EVM (95Pctl)>,<8: EVM (Total Peak)>,
 <9: Mag Err (Result)>,<10: Mag Err (Peak)>,
 <11: Mag Err (atSym)>,<12: Mag Err (Rms)>,
 <13: Mag Err (Avg)>,<14: Mag Err (StdDev)>,
 <15: Mag Err (Total Peak)>,<16: Phase Err (Result)>,
 <17: Phase Err (Peak)>,<18: Phase Err (atSym)>,
 <19: Phase Err (Rms)>,<20: Phase Err (Avg)>,
 <21: Phase Err (StdDev)>,<22: Phase Err (Total Peak)>,
 <23: Carrier Freq Err (Result)>,<24: Carrier Freq Err (Rms)>,
 <25: Carrier Freq Err (Avg)>,<26: Carrier Freq Err (StdDev)>,
 <27: Ampt Droop (Result)>,<28: Ampt Droop (Rms)>,
 <29: Ampt Droop (Avg)>,<30: Ampt Droop (StdDev)>,
 <31: Origin Offset (Result)>,<32: Origin Offset (Rms)>,
 <33: Origin Offset (Avg)>,<34: Origin Offset (StdDev)>

<35: IQ Imbalance (Result)>,<36: IQ Imbalance (Rms)>,
 <37: IQ Imbalance (Avg)>,<38: IQ Imbalance (StdDev)>,
 <39: Mean Power (Result)>,<40: Mean Power (Peak)>,
 <41: Mean Power (atSym)>,<42: Mean Power (Rms)>,
 <43: Mean Power (Avg)>,<44: Mean Power (StdDev)>,
 <45: Mean Power (Total Peak)>,<46: RHO (Result)>,
 <47: RHO (Rms)>,<48: RHO (Avg)>,
 <49: RHO (StdDev)>,<50: Trigger to Sync (Result)>,
 <51: Trigger to Sync (Rms)>,<52: Trigger to Sync (Avg)>,
 <53: Trigger to Sync (StdDev)>,<54: Pilot Level Error (Result)>,
 <55: Pilot Level Error (Rms)>,<56: Pilot Level Error (Avg)>,
 <57: Pilot Level Error (StdDev)>

Modulation types other than FSK and VSB, number of measurement values: 53

<1: EVM (Result)>,<2: EVM (Peak)>,
 <3: EVM (atSym)>,<4: EVM (Rms)>,
 <5: EVM (Avg)>,<6: EVM (StdDev)>,
 <7: EVM (95Pctl)>,<8: EVM (Total Peak)>,
 <9: Mag Err (Result)>,<10: Mag Err (Peak)>,
 <11: Mag Err (atSym)>,<12: Mag Err (Rms)>,
 <13: Mag Err (Avg)>,<14: Mag Err (StdDev)>,
 <15: Mag Err (Total Peak)>,<16: Phase Err (Result)>,
 <17: Phase Err (Peak)>,<18: Phase Err (atSym)>,
 <19: Phase Err (Rms)>,<20: Phase Err (Avg)>,
 <21: Phase Err (StdDev)>,<22: Phase Err (Total Peak)>,
 <23: Carrier Freq Err (Result)>,<24: Carrier Freq Err (Rms)>,
 <25: Carrier Freq Err (Avg)>,<26: Carrier Freq Err (StdDev)>,
 <27: Ampt Droop (Result)>,<28: Ampt Droop (Rms)>,
 <29: Ampt Droop (Avg)>,<30: Ampt Droop (StdDev)>,
 <31: Origin Offset (Result)>,<32: Origin Offset (Rms)>,
 <33: Origin Offset (Avg)>,<34: Origin Offset (StdDev)>,
 <35: IQ Imbalance (Result)>,<36: IQ Imbalance (Rms)>,
 <37: IQ Imbalance (Avg)>,<38: IQ Imbalance (StdDev)>,
 <39: Mean Power (Result)>,<40: Mean Power (Peak)>,
 <41: Mean Power (atSym)>,<42: Mean Power (Rms)>,
 <43: Mean Power (Avg)>,<44: Mean Power (StdDev)>,
 <45: Mean Power (Total Peak)>,<46: RHO (Result)>,
 <47: RHO (Rms)>,<48: RHO (Avg)>,
 <49: RHO (StdDev)>,<50: Trigger to Sync (Result)>,
 <51: Trigger to Sync (Rms)>,<52: Trigger to Sync (Avg)>,
 <53: Trigger to Sync (StdDev)>,>

TRIGger Subsystem

The TRIGger subsystem controls the trigger characteristics of the active measurement window.

COMMAND	PARAMETER	UNIT	COMMENT
TRIGger :SEquence :LEVel :[:EXternal]	<numeric_value>		

:TRIGger[:SEquence]:LEVel[:EXternal] 0.5 V ... 3.5 V

This command activates an external TTL trigger signal, which is applied to the EXT TRIGGER /GATE input on the rear of the instrument. The external trigger level can be adjusted in the range from 0.5V to 3.5V.

Example: "TRIG:LEV 2.5" 'sets the external trigger level to 2.5 V.

Characteristics: *RST value: 1.4V
SCPI: device-specific

Mode: all

Table of Softkeys Assigned to IEC/IEEE Bus Commands

Hotkey VSA

VSA	INST:SEL DDEM OR INST:NSEL 2
-----	------------------------------

Hotkeys of Option

EXIT VSA	INST:SEL SAN OR INST:NSEL 1 -
PRESET VSA	In remote control, all device settings are reset by means of the *RST command. -
SETTINGS	-
HOME VSA	The Hotkey HOME VSA opens the menu selection for Option R&S FSQ-K70/FSMR-B73/FSU-B73. The ADJUST REF LEVEL softkey directly results in a setting. It is therefore described first. Then, the menus are described in the order of the softkeys occurring in the menus.
ADJUST REF LEVEL	:SENSe:DDEMod:PRESet:RLEVel

Menu DIGITAL STANDARD

DIGITAL STANDARD	--
GENERIC STD LIST	No function in the IEC/IEEE bus operation.
STANDARD LIST	Queries all available standards. [SENSe<1 2>:]DDEMod:STANdard:CATalog? [SENSe<1 2>:]DDEMod:PRESet[:STANdard]...<file_name > GSM EDGE FW3Gppcdma RW3Gppcdma FQCDma F95Cdma RQCDma R95Cdma CDMA2000 F1CDma2000 R1CDma2000 FNADc RNADc PDCDown PDCup PHS TETRa DECT DCS1800 PCS1900 <file_name > = Standards are selected via the file name. <standard > = Some standards can be selected via a parameter value (character data) also.
DELETE STANDARD	[SENSe<1 2>:]DDEMod:STANdard:DELeTe <file_name>
SAVE AS STANDARD	[SENSe<1 2>:]DDEMod:STANdard:GROup <string> [SENSe<1 2>:]DDEMod:STANdard:COMMeNt <string>i [SENSe<1 2>:]DDEMod:STANdard:PREFix <string> [SENSe<1 2>:]DDEMod:STANdard:SAVE <file_name>
CANCEL	No function in the IEC/IEEE bus operation.

SAVE	See softkey SAVE AS STANDARD
STANDARD DEFAULTS	[SENSe<1 2>:] DDEMod:STANdard:PRESet
NEW GENERIC..	No function in the IEC/IEEE bus operation.
EDIT GENERIC..	No function in the IEC/IEEE bus operation.
EDIT GENERIC STD	No function in the IEC/IEEE bus operation.
SHOW ALL STANDARDS	Automatically performed in the IEC/IEEE bus operation.
INSERT STANDARD	Automatically performed in the IEC/IEEE bus operation.
REMOVE STANDARD	Automatically performed in the IEC/IEEE bus operation.
CANCEL	No function in the IEC/IEEE bus operation.
SAVE	No function in the IEC/IEEE bus operation.
DELETE GENERIC STD	No function in the IEC/IEEE bus operation.

Menu MODULATION SETTINGS

MODULATION
SETTINGSSYM RATE
(270.833kHz)MODULATION
& MAPPING

--

:[SENSe<1|2>:]DDEMod:SRATE <num_value>

Einstellen von vordefinierten Standard-Mappings:

Modulation BPSK

:[SENSe<1|2>:]DDEMod:FORMat PSK

:[SENSe<1|2>:]DDEMod:PSK:NState 2

Modulation QPSK

:[SENSe<1|2>:]DDEMod:FORMat QPSK

:[SENSe<1|2>:]DDEMod:QPSK:FORMat NORMal

Modulation OQPSK

:[SENSe<1|2>:]DDEMod:FORMat QPSK

:[SENSe<1|2>:]DDEMod:QPSK:FORMat OFFSet

Modulation 8PSK

:[SENSe<1|2>:]DDEMod:FORMat PSK

:[SENSe<1|2>:]DDEMod:PSK:FORMat NORMal

:[SENSe<1|2>:]DDEMod:PSK:NState 8

Modulation DQPSK

:[SENSe<1|2>:]DDEMod:FORMat QPSK

:[SENSe<1|2>:]DDEMod:QPSK:FORMat DIFFerential

Modulation D8PSK

:[SENSe<1|2>:]DDEMod:FORMat PSK

:[SENSe<1|2>:]DDEMod:PSK:FORMat DIFFerential

:[SENSe<1|2>:]DDEMod:PSK:NState 8

Modulation P1/4-DQPSK

:[SENSe<1|2>:]DDEMod:FORMat QPSK

:[SENSe<1|2>:]DDEMod:QPSK:FORMat DPI4

Modulation 3P/8-8PSK

:[SENSe<1|2>:]DDEMod:FORMat PSK

:[SENSe<1|2>:]DDEMod:PSK:FORMat N3Pi8

:[SENSe<1|2>:]DDEMod:PSK:NState 8

Modulation DMSK

:[SENSe<1|2>:]DDEMod:FORMat MSK

:[SENSe<1|2>:]DDEMod:MSK:FORMat TYPE2 | DIFFerential

Modulation MSK

:[SENSe<1|2>:]DDEMod:FORMat MSK

:[SENSe<1|2>:]DDEMod:MSK:FORMat TYPE1 | NORMal

Modulation 2FSK

:[SENSe<1|2>:]DDEMod:FORMat FSK

:[SENSe<1|2>:]DDEMod:FSK:NState 2

Modulation 4FSK

:[SENSe<1|2>:]DDEMod:FORMat FSK

:[SENSe<1|2>:]DDEMod:FSK:NState 4

Modulation 16QAM

:[SENSe<1|2>:]DDEMod:FORMat QAM

:[SENSe<1|2>:]DDEMod:QAM:NState 16

Modulation 32QAM

:[SENSe<1|2>:]DDEMod:FORMat QAM

:[SENSe<1|2>:]DDEMod:QAM:NState 32

Modulation 64QAM

:[SENSe<1|2>:]DDEMod:FORMat QAM

:[SENSe<1|2>:]DDEMod:QAM:NState 64

Modulation 128QAM

:[SENSe<1|2>:]DDEMod:FORMat QAM

:[SENSe<1|2>:]DDEMod:QAM:NState 128

Modulation 256QAM

:[SENSe<1|2>:]DDEMod:FORMat QAM

:[SENSe<1|2>:]DDEMod:QAM:NState 256

Selecting the mappings:

:[SENSe<1|2>:]DDEMod:MAPPING <mapping_name>

Queries the available mappings for the modulation type:

:[SENSe<1|2>:]DDEMod:MAPPING:CATalog?

MODULATION FILTER	: [SENSe<1 2>:] DDEMod:FiLTeR:MoDulation <TX-Filter>, <ISI-Filter>, <MEAS-FILTER> Queries the available filters: : [SENSe<1 2>:] DDEMod:FiLTeR:CATalog?
EQUALIZER SETTINGS	
EQUALIZER ON OFF	: [SENSe<1 2>:] DDEMod:EQUalizer[:STATe] ON OFF
EQUALIZER TRAIN	: [SENSe<1 2>:] DDEMod:EQUalizer:ADAPt ON
EQUALIZER FREEZE	: [SENSe<1 2>:] DDEMod:EQUalizer:ADAPt OFF
EQUALIZER RESET	: [SENSe<1 2>:] DDEMod:EQUalizer:RESet
EQUALIZER LENGTH	: [SENSe<1 2>:] DDEMod:EQUalizer:LENGth <num_value>
EQUALIZER STEP	: [SENSe<1 2>:] DDEMod:EQUalizer:CNVR <num_value>
EQUALIZER LOAD	: [SENSe<1 2>:] DDEMod:EQUalizer:LOAD <name>
EQUALIZER SAVE	: [SENSe<1 2>:] DDEMod:EQUalizer:SAVE <name>
EQUALIZER DELETE	: [SENSe<1 2>:] DDEMod:EQUalizer:DELeTe <name>
ALPHA/BT (0.3)	: [SENSe<1 2>:] DDEMod:FiLTeR:ALPha <num_value>
FSK DEV (123.4 kHz)	: CALCulate<1 2>:FSK:DEVIation:REFeRence <num_value>
POINTS /SYMB (4)	: [SENSe<1 2>:] DDEMod:PRATe 1 2 4 8 16
NEW USER SET	No function in the IEC/IEEE bus operation.
DELETE USER SET	No function in the IEC/IEEE bus operation.
SAVE USER SET	No function in the IEC/IEEE bus operation.

Menu DEMOD SETTINGS

DEMOM SETTINGS	--
RECORD LENGTH	
RECORD LEN (AUTO)	: [SENSe<1 2>:] DDEMod:RLENGth:AUTO ON OFF

RECORD LEN (8 kSym)	:[SENSe<1 2>:]DDEMod:RLENgth <num_value> SYM Query returns value in seconds
RECORD LEN (1.234 ms)	:[SENSe<1 2>:]DDEMod:RLENgth <num_value> S Query returns value in seconds.
RESULT LENGTH	:[SENSe<1 2>:]DDEMod:TIME <num_value>
EVAL LINES	-- Both evaluation lines are always switched on/off.
EVAL LINE 1	:CALCulate<1 2>:ELIN:STATE ON :CALCulate<1 2>:ELIN<1> <num_value>
EVAL LINE 2	:CALCulate<1 2>:ELIN:STATE ON :CALCulate<1 2>:ELIN<2> <num_value>
FORCE WB PATH	:[SENSe<1 2>:]DDEMod:WBANd[:STATe] ON OFF
MULTI ON OFF	:[SENSe<1 2>:]DDEMod:MBURst ON OFF
FORCE WB PATH	:[SENSe<1 2>:]DDEMod:WBANd[:STATe] ON OFF
NORMALIZE ON OFF	:[SENSe<1 2>:]DDEMod:NORMAlize ON OFF Normalize for PSK / MSK / QAM
SIDE BAND NORM INV	:[SENSe<1 2>:]DDEMod:SBANd NORMAl INVerse
POINTS/SYM (4)	:[SENSe<1 2>:]DDEMod:PRATe 1 2 4 8 16

Menu BURST & PATTERN

BURST & PATTERN	--
BURST SRCH ON OFF	: [SENSe<1 2>:]DDEMod:SEARCh:BURSt[:STATe] ON OFF
THRESHOLD (-20dBRef)	--
THRESHOLD AUTO	: [SENSe<1 2>:]DDEMod:SEARCh:BURSt:THReshold:AUTO ON
THRESHOLD RELATIVE	: [SENSe<1 2>:]DDEMod:SEARCh:BURSt:THReshold:AUTO OFF : [SENSe<1 2>:]DDEMod:SEARCh:BURSt:THReshold:MODE REL : [SENSe<1 2>:]DDEMod:SEARCh:BURSt:THReshold <num_value>
THRESHOLD ABSOLUTE	: [SENSe<1 2>:]DDEMod:SEARCh:BURSt:THReshold:AUTO OFF : [SENSe<1 2>:]DDEMod:SEARCh:BURSt:THReshold:MODE ABS : [SENSe<1 2>:]DDEMod:SEARCh:BURSt:THReshold[:LEVel] <num_value>
HYSTERESIS MAN	: [SENSe<1 2>:]DDEMod:SEARCh:BURSt:HYSTeresis[:LEVel] <num_value>
EXPERT SETTINGS	: [SENSe<1 2>:]DDEMod:SEARCh:BURSt:LENGth[:MINimum] <num_value> : [SENSe<1 2>:]DDEMod:SEARCh:BURSt:LENGth:MAXimum <num_value> : [SENSe<1 2>:]DDEMod:SEARCh:BURSt:SKIP:RISing <num_val> : [SENSe<1 2>:]DDEMod:SEARCh:BURSt:SKIP:FALLing <num_value> : [SENSe<1 2>:]DDEMod:SEARCh:BURSt:GLENGth[:MINimum] <num_value>
MEAS ONLY ON BURST	: [SENSe<1 2>:]DDEMod:SEARCh:BURSt:MODE BURSt MEAS
BURST SGL MULTI	: [SENSe<1 2>:]DDEMod:SEARCh:BURSt:MBURSt ON OFF
PAT SRCH ON OFF	: [SENSe<1 2>:]DDEMod:SEARCh:SYNC:STATe ON OFF : [SENSe<1 2>:]DDEMod:SEARCh:SYNC:FOUND?
SELECT PATTERN	: [SENSe<1 2>:]DDEMod:SEARCh:SYNC:SELEct "pattern_name_1", position_1, "pattern_name_2", position_2, ..., "pattern_name_n", position_n
PATTERN SETTINGS	--
STD PATT LIST	: [SENSe<1 2>:]DDEMod:SEARCh:SYNC:CATalog? CURRent
PATTERN LIST	: [SENSe<1 2>:]DDEMod:SEARCh:SYNC:CATalog? ALL
SHRINK PAT LIST	--
ADD PAT TO STD	: [SENSe<1 2>:]DDEMod:SEARCh:SYNC:PATtern:ADD <pat_name>
NEW PATTERN	--

PATTERN SETTINGS	<p>Commands for columns of table:</p> <pre>:[SENSe<1 2>:]DDEMod:SEARch:SYNC:NAME <pattern_name> :[SENSe<1 2>:]DDEMod:SEARch:SYNC:TEXT <string> :[SENSe<1 2>:]DDEMod:SEARch:SYNC:COMMENT <string> :[SENSe<1 2>:]DDEMod:SEARch:SYNC:NState 2 4 8 16 32 64 128 256 512 1024</pre>
PATTERN SYMBOLS	<p>Commands for columns of table:</p> <pre>:[SENSe<1 2>:]DDEMod:SEARch:SYNC:NAME <string></pre>
(*)	<pre>:[SENSe<1 2>:]DDEMod:SEARch:SYNC:DATA "FFFF"</pre>
INSERT	No function in the IEC/IEEE bus operation.
EDIT	No function in the IEC/IEEE bus operation.
DELETE	No function in the IEC/IEEE bus operation.
SAVE	Automatically performed in the IEC/IEEE bus operation.
CANCEL	No function in the IEC/IEEE bus operation.
EDIT PATTERN	Editing is not possible via IEC/IEEE bus. Only overwriting is possible
DELETE PATTERN	<pre>:[SENSe<1 2>:]DDEMod:SEARch:SYNC:SEL "GSM_1" :[SENSe<1 2>:]DDEMod:SEARch:SYNC:DELeTe</pre>
REMOVE PAT FROM STD	<pre>:[SENSe<1 2>:]DDEMod:SEARch:SYNC:PATtern:REMOve <pattern_name></pre>
REMOVE ALL FROM STD	<pre>:[SENSe<1 2>:]DDEMod:SEARch:SYNC:PATtern:REMOve ALL</pre>
MEAS ONLY ON PATT	<pre>:[SENSe<1 2>:]DDEMod:SEARch:SYNC:MODE MEAS SYNC</pre>

ERROR SPECTRUM	:CALCulate<1 2>:DDEM:SPECTrum[:STATe] ON OFF
ERROR STATISTIC	:CALCulate:STATistics:CCDF[:STATe] ON OFF
CAPTURE BUFFER	:CALCulate<1 2>:FEED `TCAP`
MAG CAP BUFFER	:CALCulate<1 2>:FORMat MAGNitude
FREQUENCY ABS REL	:CALCulate<1 2>:FORMat FREquency :DISPlay[:WINDow<1 2>]:TRACe<1...4>:Y[:SCALe]:MODE ABSolute RELative
REAL/IMAG	:CALCulate<1 2>:FORMat RIMag
SPECTRUM	:CALCulate<1 2>:DDEM:SPECTrum[:STATe] ON OFF
SIGNAL STATISTIC	:CALCulate:STATistics:CCDF[:STATe] ON OFF
SYMBOLS & MOD ACC	:CALCulate<1 2>:FEED `XTIM:DDEM:SYMB` Summary of result query: :CALCulate:MARKer:FUNCTion:DDEM:STATistic:ADRoop? <none> RMS AVG SDEV :CALCulate:MARKer:FUNCTion:DDEM:STATistic:CFERror? <none> RMS AVG SDEV TPEak :CALCulate:MARKer:FUNCTion:DDEM:STATistic:DTTStart? <none> RMS AVG SDEV :CALCulate:MARKer:FUNCTion:DDEM:STATistic:EVM? <none> PEAK ASYM RMS AVG SDEV PCTL TPEak :CALCulate:MARKer:FUNCTion:DDEM:STATistic:FSK:DERRor? <none> PEAK ASYM RMS AVG SDEV TPEak :CALCulate:MARKer:FUNCTion:DDEM:STATistic:FSK:MDEVIation? <none> RMS AVG SDEV :CALCulate:MARKer:FUNCTion:DDEM:STATistic:FSK:CFDRift? <none> RMS AVG SDEV :CALCulate:MARKer:FUNCTion:DDEM:STATistic:GIMBalance? <none> RMS AVG SDEV :CALCulate:MARKer:FUNCTion:DDEM:STATistic:IQIMBalance? <none> RMS AVG SDEV :CALCulate:MARKer:FUNCTion:DDEM:STATistic:MERRor? <none> PEAK ASYM RMS AVG SDEV TPEak :CALCulate:MARKer:FUNCTion:DDEM:STATistic:MPower? <none> PEAK ASYM RMS AVG SDEV TPEak :CALCulate:MARKer:FUNCTion:DDEM:STATistic:OOFfset? <none> RMS AVG SDEV :CALCulate:MARKer:FUNCTion:DDEM:STATistic:PERRor? <none> PEAK ASYM RMS AVG SDEV TPEak :CALCulate:MARKer:FUNCTion:DDEM:STATistic:QERRor? <none> RMS AVG SDEV :CALCulate:MARKer:FUNCTion:DDEM:STATistic:RHO? <none> RMS AVG SDEV :CALCulate:MARKer:FUNCTion:DDEM:STATistic:SNR? <none> RMS AVG SDEV
EQUALIZER	:CALCulate<1 2>:FEED `XTIM:DDEM:IMP` :CALCulate<1 2>:FEED `XFR:DDEM:RAT`
MAGNITUDE (REL/ABS)	:CALCulate<1 2>:FEED `XTIM:DDEM:IMP` :CALCulate<1 2>:FORMat MAGNitude :DISPlay[:WINDow<1 2>]:TRACe<1...4>:Y:SPACing LINear LOGarithmic
PHASE (WRAP/UNWR)	:CALCulate<1 2>:FEED `XTIM:DDEM:IMP` :CALCulate<1 2>:FORMat PHASe UPHase

REAL/IMAG	:CALCulate<1 2>:FEED `XTIM:DDEM:IMP' :CALCulate<1 2>:FORMat RIMag
GROUP DELAY	:CALCulate<1 2>:FEED `XFR:DDEM:RAT' :CALCulate<1 2>:FORMat GDElay
PHASE RESP (WRAP/UNWR)	:CALCulate<1 2>:FEED `XFR:DDEM:RAT' :CALCulate<1 2>:FORMat PHASe UPHase
FREQ RESP (LIN)	:CALCulate<1 2>:FEED `XFR:DDEM:RAT' :CALCulate<1 2>:FORMat MAGNitude :DISPlay[:WINDow<1 2>]:TRACe<1...4>:Y:SPACing LINear LOGarithmic
CHAN RESP (LIN)	:CALCulate<1 2>:FEED `XFR:DDEM:RAT' :CALCulate<1 2>:FORMat MAGNitude :DISPlay[:WINDow<1 2>]:TRACe<1...4>:Y:SPACing LINear LOGarithmic
RESULT LENGTH	: [SENSe<1 2>:]DDEMod:TIME <num_value>
NORMALIZE ON OFF	Normalize for PSK / MSK / QAM : [SENSe<1 2>:]DDEMod:NORMalize ON OFF
POINTS /SYM (4)	: [SENSe<1 2>:]DDEMod:PRATe 1 2 4 8 16
EVM CALC (MAX)	: [SENSe<1 2>:]DDEMod:ECALc:OFFSet ON OFF
OFFSET EVM ON OFF	: [SENSe<1 2>:]DDEMod:ECALc:OFFSet ON OFF
HIGHLIGHT	No function in the IEC/IEEE bus operation.
REFDEVCOMP ON OFF	Normalize für FSK :CALCulate<1 2>:FSK:DEViatiOn:COMPensatiOn ON OFF
EVM CALC 8 [MAX])	: [SENSe<1 2>:]DDEMod:ECALc SYMBol SIGNAL

Menu FIT TRACE

FIT TRACE	--
FIT TRIGGER	:CALCulate<1 2>:TRACe<1...3>:ADJust TRIGger
FIT BURST	:CALCulate<1 2>:TRACe<1...3>:ADJust BURSt
FIT PATTERN	:CALCulate<1 2>:TRACe:ADJust PATTern
FIT ALIGN LEFT	:CALCulate<1 2>:TRACe<1...3>:ADJust:ALIGNment LEFT
FIT ALIGN CENTER	:CALCulate<1 2>:TRACe<1...3>:ADJust:ALIGNment CENTER
FIT ALIGN RIGHT	:CALCulate<1 2>:TRACe<1...3>:ADJust:ALIGNment RIGHT

FIT ALIGN (20%)	:CALCulate<1 2>:TRACe<1...3>:ADJust:ALIGNment:VALue <num_value>
SET SYMB# (-10 SYM)	:DISPlay[:WINDow<1 2>]:TRACe<1...4>:X[:SCALe]:VOFFset <num_value>
RECORD LEN AUTO	:[SENSe<1 2>:]DDEMod:RELENgth:AUTO ON OFF
RECORD LEN (8.0kSYM)	: [SENSe<1 2>:]DDEMod:RELENgth <num_value> SYM
RECORD LEN (1.234 ms)	: [SENSe<1 2>:]DDEMod:RELENgth <num_value> S
PAT POS (100 SYM)	: [SENSe<1 2>:]DDEMod:STANDard:SYNC:OFFSet <num_value>
RESULT LENGTH	: [SENSe<1 2>:]DDEMod:TIME <num_value>
FIT OFFSET (57SYM)	:CALCulate<1 2>:TRACe<1...3>:ADJust:ALIGNment:OFFSet <num_value>

Menu ZOOM

ZOOM START	--
ZOOM START	: [SENSe<1 2>:]DDEMod:SEARCh:MBURst:START <num_value>
ZOOM LENGTH	: [SENSe<1 2>:]DDEMod:SEARCh:MBURst:LENgth <num_value>
DEMOD NEXT RIGHT	: [SENSe<1 2>:]DDEMod:SEARCh:MBURst:FIND:NEXT
DEMOD RESTART	: [SENSe<1 2>:]DDEMod:SEARCh:MBURst:FIND:FIRSt
DEMOD @ ZOOM START	: [SENSe<1 2>:]DDEMod:SEARCh:MBURst:FIND:START
CAPTURE AUTO OFF	: [SENSe<1 2>:]DDEMod:SEARCh:MBURst:CAPTure:AUTO ON OFF
MULTI ON OFF	: [SENSe<1 2>:]DDEMod:SEARCh:MBURst:STATe ON OFF

Menu RANGE

RANGE	--
X-AXIS QUANTIZE	CALCulate:STATistics:SCALE:X:BCount <num_value>
X-AXIS /DIV	:DISPlay[:WINDow<1 2>]:TRACe<1..3>:X[:SCALE]:PDIVision <num_value>
X-AXIS REF VALUE	:DISPlay[:WINDow<1 2>]:TRACe<1..4>:X[:SCALE]:RVALue <num_value>
X-AXIS REF POS	:DISPlay[:WINDow<1 2>]:TRACe<1..4>:X[:SCALE]:RPOSITION 0..100PCT
Y-AXIS /DIV	:DISPlay[:WINDow<1 2>]:TRACe<1..3>:Y[:SCALE]:PDIVision <num_value>
Y-AXIS REF VALUE	:DISPlay[:WINDow<1 2>]:TRACe<1..4>:Y[:SCALE]:RVALue <num_value>
Y-AXIS REF POS	:DISPlay[:WINDow<1 2>]:TRACe<1..4>:Y[:SCALE]:RPOSITION 0..100PCT
DEFAULT SETTINGS	--
BIN	No function in the IEC/IEEE bus operation.
OCT	No function in the IEC/IEEE bus operation.
HEX	No function in the IEC/IEEE bus operation.
DEC	No function in the IEC/IEEE bus operation.

Menu FACTORY DEFAULTS

FACTORY DEFAULTS	No function in the IEC/IEEE bus operation.
GENERIC STANDARDS	:[SENSe<1 2>:]DDEMod:FACTory GStandards
STANDARDS	:[SENSe<1 2>:]DDEMod:FACTory STANDards
MAPPINGS	:[SENSe<1 2>:]DDEMod:FACTory MAPPings
PATTERN	:[SENSe<1 2>:]DDEMod:FACTory PATTerns
FILTERS	:[SENSe<1 2>:]DDEMod:FACTory FILTers
EQUALIZERS	:[SENSe<1 2>:]DDEMod:FACTory EQUalizer

ALL

: [SENSe<1|2>:] DDEMod:FACTory ALL

Menu IMPORT

IMPORT

GENERIC STANDARDS

: [SENSe<1|2>:] DDEMod:IMPorT:GStandard <name>,<path>

STANDARDS

: [SENSe<1|2>:] DDEMod:IMPorT:STANdard <name>,<path>

MAPPINGS

: [SENSe<1|2>:] DDEMod:IMPorT:MAPPing <name>,<path>

PATTERN

: [SENSe<1|2>:] DDEMod:IMPorT:PATTern <name>,<path>

FILTERS

: [SENSe<1|2>:] DDEMod:IMPorT:FILTer <name>,<path>

EQUALIZERS

: [SENSe<1|2>:] DDEMod:IMPorT:EQUalizer <name>,<path>

Menu EXPORT

EXPORT

GENERIC STANDARDS

: [SENSe<1|2>:] DDEMod:EXPorT:GStandard <name>,<path>

STANDARDS

: [SENSe<1|2>:] DDEMod:EXPorT:STANdard <name>,<path>

MAPPINGS

: [SENSe<1|2>:] DDEMod:EXPorT:MAPPing <name>,<path>

PATTERN

: [SENSe<1|2>:] DDEMod:EXPorT:PATTern <name>,<path>

FILTERS

: [SENSe<1|2>:] DDEMod:EXPorT:FILTer <name>,<path>

EQUALIZERS

: [SENSe<1|2>:] DDEMod:EXPorT:EQUalizer <name>,<path>

FREQ Key

FREQ

CENTER

: [SENSe<1|2>:] FREQuency: CENTer <num_value>

CF STEP
AUTO MAN

: [SENSe<1|2>:] FREQuency: CENTer: STEP: AUTO ON|OFF

CF STEP
SIZE

: [SENSe<1|2>:] FREQuency: CENTer: STEP <num_value>

FREQUENCY
OFFSET

: [SENSe<1|2>:] FREQuency: OFFSet <num_value>

SPAN Key

SPAN

The functions of the SPAN key are irrelevant in the operating mode VSA.

AMPT Key

AMPT

REF
LEVEL

DISPlay[:WINDow<1|2>]: TRACe<1..3>: Y[:SCALe]: RLEVel <num_value>

REF LEVEL
UNIT

: CALCulate<1|2>: UNIT: POWer DBM | DBMV | DBUV | DBUA | DBPW | VOLT | AMPere | WATT

RANGE

--

X-AXIS
QUANTIZE

CALCulate: STATistics: SCALe: X: BCOunt <num_value>

X-AXIS
/DIV

: DISPlay[:WINDow<1|2>]: TRACe<1..3>: X[:SCALe]: PDIVision <num_value>

X-AXIS
REF VALUE

: DISPlay[:WINDow<1|2>]: TRACe<1..4>: X[:SCALe]: RVALue <num_value>

X-AXIS
REF POS

: DISPlay[:WINDow<1|2>]: TRACe<1..4>: X[:SCALe]: RPOSITION 0..100PCT

Y-AXIS
/DIV

: DISPlay[:WINDow<1|2>]: TRACe<1..3>: Y[:SCALe]: PDIVision <num_value>

Y-AXIS
REF VALUE

: DISPlay[:WINDow<1|2>]: TRACe<1..4>: Y[:SCALe]: RVALue <num_value>

Y-AXIS
REF POS

: DISPlay[:WINDow<1|2>]: TRACe<1..4>: Y[:SCALe]: RPOSITION 0..100PCT

DEFAULT
SETTINGS

--

BIN	No function in the IEC/IEEE bus operation.
OCT	No function in the IEC/IEEE bus operation.
HEX	No function in the IEC/IEEE bus operation.
DEC	No function in the IEC/IEEE bus operation.
DISPLAY UNIT	--
Y UNIT LOG DB	:DISPlay:WINDow:TRACe:Y:SPACing LOG
Y UNIT LINEAR	:DISPlay:WINDow:TRACe:Y:SPACing LIN
Y UNIT DEG	:CALCulate<1 2>:UNIT:ANGLE DEG
Y UNIT RAD	:CALCulate<1 2>:UNIT:ANGLE RAD
X UNIT TIME	:CALCulate<1 2>:X:UNIT:TIME S
X UNIT SYMBOL	:CALCulate<1 2>:X:UNIT:TIME SYM
RF INPUT AC DC	:INPut<1 2>:COUPling AC DC
RF ATTEN MANUAL	:INPut<1 2>:ATTenuation:AUTO OFF :INPut<1 2>:ATTenuation <num_value>
RF ATTEN AUTO	:INPut<1 2>:ATTenuation:AUTO ON
ADJUST REF LEVEL	:SENSe:DDEMod:PRESet:RLEVel
REF LEVEL OFFSET	:DISP[:WIND<1 2>]:TRACe<1...3>:Y[:SCALE]:RLEVel:OFFSet <num_value>
Mixer	--
MIXER LVL AUTO	:INPut:MIXer:AUTO ON
MIXER LVL MANUAL	:INPut:MIXer:AUTO OFF :INPut:MIXer[:POWER] <num_value>

MKR Key

MKR	
MARKER 1..4	CALCulate<1 2>:MARKer<1...4>[:STATe] ON OFF CALCulate<1 2>:MARKer<1...4>:X <numeric value> CALCulate<1 2>:MARKer<1...4>:Y? CALCulate<1 2>:DELTamarker1[:STATe] ON OFF CALCulate<1 2>:DELTamarker<1...4>:X <numeric value> CALCulate<1 2>:DELTamarker<1...4>:Y?
MARKER NORM DELTA	CALCulate<1 2>:DELTamarker<1...4>[:STATe] ON OFF;
ALL MARKER OFF	CALCulate<1 2>:MARKer<1...4>:AOFF CALCulate<1 2>:DELTamarker<1...4>:AOFF
MKR-> TRACE	CALCulate<1 2>:MARKer<1...4>:TRACe <num_value> CALCulate<1 2>:DELTamarker<1...4>:TRACe <num_value>

MKR -> Key

MKR->	
SELECT MARKER	--
MAX PEAK	:CALCulate<1 2>:MARKer<1..4>:MAXimum[:PEAK] :CALCulate<1 2>:DELTamarker<1..4>:MAXimum[:PEAK]
MIN PEAK	:CALCulate<1 2>:MARKer<1..4>:MINimum[:PEAK] :CALCulate<1 2>:DELTamarker<1..4>:MINimum[:PEAK]
MAX PEAK	:CALCulate<1 2>:MARKer<1..4>:MAXimum:APEak :CALCulate<1 2>:DELTamarker<1..4>:MAXimum:APEak
SEARCH LIMITS	--
LEFT LIMIT	:CALCulate<1 2>:MARKer<1..4>:X:SLIMits[:STATe] ON OFF :CALCulate<1 2>:MARKer<1..4>:X:SLIMits:LEFT <num_value>
RIGHT LIMIT	:CALCulate<1 2>:MARKer<1..4>:X:SLIMits[:STATe] ON OFF :CALCulate<1 2>:MARKer<1..4>:X:SLIMits:RIGHT <num_value>
THRESHOLD	:CALCulate<1 2>:THReshold[:STATe] ON OFF :CALCulate<1 2>:THReshold <num_value>
LIMITS = EVAL LINES	:CALCulate<1 2>:MARKer<1..4>:X:SLIMits[:STATe] ON :CALCulate<1 2>:MARKer<1..4>:X:SLIMits:LEFT <num_value> :CALCulate<1 2>:MARKer<1..4>:X:SLIMits:RIGHT <num_value>
SEARCH LIM OFF	:CALCulate<1 2>:MARKer<1..4>:X:SLIMits[:STATe] OFF :CALCulate<1 2>:THReshold[:STATe] ON OFF
PEAK EXCURSION	:CALCulate<1 2>:MARKer<1..4>:PEXCursion <num_value>
MKR -> TRACE	:CALCulate<1 2>:MARKer<1..4>:TRACe <num_value> :CALCulate<1 2>:DELTamarker <1..4>:TRACe <num_value>

MKR FCTN Key

MKR FUNC

PndB OUT ()

SUMMARY MARKER

SUM MKR ON OFF

MAX PEAK

+ PEAK

- PEAK

-/- PEAK

RMS

MEAN

STANDARD DEVIATION

LIMITS ON OFF

START LIMIT

STOP LIMIT

MAX HOLD ON OFF

```

CALCulate<1|2>:MARKer<1..4>:FUNCTION:CPOINT[:STATE] ON|OFF
CALCulate<1|2>:MARKer<1..4>:FUNCTION:CPOINT:VALUE <num_value>
CALCulate<1|2>:MARKer<1..4>:FUNCTION:CPOINT:PHDIFF?
CALCulate<1|2>:MARKer<1..4>:FUNCTION:CPOINT:POWER?
CALCulate<1|2>:MARKer<1..4>:FUNCTION:SUMMARY:MAXIMUM[:STATE] ON
CALCulate<1|2>:MARKer<1..4>:FUNCTION:SUMMARY:MPEAK[:STATE] ON
CALCulate<1|2>:MARKer<1..4>:FUNCTION:SUMMARY:MIDDLE[:STATE] ON| OFF
CALCulate<1|2>:MARKer<1..4>:FUNCTION:SUMMARY:RMS[:STATE] ON
CALCulate<1|2>:MARKer<1..4>:FUNCTION:SUMMARY:PPEAK[:STATE] ON
CALCulate<1|2>:MARKer<1..4>:FUNCTION:SUMMARY:MEAN[:STATE] ON
CALCulate<1|2>:MARKer<1..4>:FUNCTION:SUMMARY:SDEVIATION[:STATE]ON

CALCulate<1|2>:MARKer<1..4>:FUNCTION:SUMMARY:MAXIMUM[:STATE] ON | OFF
CALCulate<1|2>:MARKer<1..4>:FUNCTION:SUMMARY:MPEAK[:STATE] ON | OFF
CALCulate<1|2>:MARKer<1..4>:FUNCTION:SUMMARY:MIDDLE[:STATE] ON| OFF
CALCulate<1|2>:MARKer<1..4>:FUNCTION:SUMMARY:RMS[:STATE] ON| OFF
CALCulate<1|2>:MARKer<1..4>:FUNCTION:SUMMARY:PPEAK[:STATE] ON| OFF
CALCulate<1|2>:MARKer<1..4>:FUNCTION:SUMMARY:MEAN[:STATE] ON| OFF
CALCulate<1|2>:MARKer<1..4>:FUNCTION:SUMMARY:SDEVIATION[:STATE]ON| OFF

CALCulate<1|2>:MARKer<1..4>:FUNCTION:SUMMARY:MAXIMUM[:STATE] ON | OFF
CALCulate<1|2>:MARKer<1..4>:FUNCTION:SUMMARY:MAXIMUM:RESULT?

CALCulate<1|2>:MARKer<1..4>:FUNCTION:SUMMARY:PPEAK[:STATE] ON | OFF
CALCulate<1|2>:MARKer<1..4>:FUNCTION:SUMMARY:PPEAK:RESULT?

CALCulate<1|2>:MARKer<1..4>:FUNCTION:SUMMARY:MPEAK[:STATE] ON | OFF
CALCulate<1|2>:MARKer<1..4>:FUNCTION:SUMMARY:MPEAK:RESULT?

CALCulate<1|2>:MARKer<1..4>:FUNCTION:SUMMARY:MIDDLE[:STATE] ON | OFF
CALCulate<1|2>:MARKer<1..4>:FUNCTION:SUMMARY:MIDDLE:RESULT?

CALCulate<1|2>:MARKer<1..4>:FUNCTION:SUMMARY:RMS[:STATE] ON | OFF
CALCulate<1|2>:MARKer<1..4>:FUNCTION:SUMMARY:RMS:RESULT?

CALCulate<1|2>:MARKer<1..4>:FUNCTION:SUMMARY:MEAN[:STATE] ON | OFF
CALCulate<1|2>:MARKer<1..4>:FUNCTION:SUMMARY:MEAN:RESULT?

CALCulate<1|2>:MARKer<1..4>:FUNCTION:SUMMARY:SDEVIATION[:STATE] ON|OFF
CALCulate<1|2>:MARKer<1..4>:FUNCTION:SUMMARY:SDEVIATION:RESULT?

CALCulate<1|2>:MARKer<1..4>:SLIMITS ON | OFF

CALCulate<1|2>:MARKer<1..4>:SLIMITS:LEFT <num_value>

CALCulate<1|2>:MARKer<1..4>:SLIMITS:RIGHT <num_value>

CALCulate<1|2>:MARKer<1..4>:FUNCTION:SUMMARY:PHOLD ON | OFF
CALCulate<1|2>:MARKer<1..4>:FUNCTION:SUMMARY:MAXIMUM:PHOLD:RESULT?
CALCulate<1|2>:MARKer<1..4>:FUNCTION:SUMMARY:MPEAK:PHOLD:RESULT?
CALCulate<1|2>:MARKer<1..4>:FUNCTION:SUMMARY:MIDDLE:PHOLD:RESULT?
CALCulate<1|2>:MARKer<1..4>:FUNCTION:SUMMARY:PPEAK:PHOLD:RESULT?
CALCulate<1|2>:MARKer<1..4>:FUNCTION:SUMMARY:RMS:PHOLD:RESULT?
CALCulate<1|2>:MARKer<1..4>:FUNCTION:SUMMARY:MEAN:PHOLD:RESULT?
CALCulate<1|2>:MARKer<1..4>:FUNCTION:SUMMARY:SDEVIATION:PHOLD:RESULT?
    
```

AVERAGE
ON OFF

CALCulate<1|2>:MARKer<1...4>:FUNction:SUMMary:AVErage ON | OFF
 CALCulate<1|2>:MARKer<1...4>:FUNction:SUMMary:MAXimum:AVErage:RESult?
 CALCulate<1|2>:MARKer<1...4>:FUNction:SUMMary:MPEak:AVErage:RESult?
 CALCulate<1|2>:MARKer<1...4>:FUNction:SUMMary:MIDDLE:AVErage:RESult?
 CALCulate<1|2>:MARKer<1...4>:FUNction:SUMMary:PPEak:AVErage:RESult?
 CALCulate<1|2>:MARKer<1...4>:FUNction:SUMMary:RMS:AVErage:RESult?
 CALCulate<1|2>:MARKer<1...4>:FUNction:SUMMary:MEAN:AVErage:RESult?
 CALCulate<1|2>:MARKer<1...4>:FUNction:SUMMary:SDEviation:AVErage:RES?

NUMBER OF
SWEEPS

[SENSe:]SWEep:COUNT <num_value>

BW Key

BW

RES BW
MANUAL

[SENSe:]BANDwidth|BWIDth[:RESolution]:AUTO OFF
 [SENSe:]BANDwidth|BWIDth[:RESolution] <num_value>

RES BW
AUTO

[SENSe:]BANDwidth|BWIDth[:RESolution]:AUTO ON

SWEEP Key

SWEEP

CONTINUOUS
SWEEP

INITiate:CONTInuous ON

SINGLE
SWEEP

INITiate:CONTInuous OFF;
 INITiate:IMMediate

DEMODO
NEXT RIGHT

: [SENSe<1|2>:]DDEMod:SEARch:MBURst:FIND:NEXT

DEMODO
RESTART

: [SENSe<1|2>:]DDEMod:SEARch:MBURst:FIND:FIRSt

DEMODO @
ZOOM START

: [SENSe<1|2>:]DDEMod:SEARch:MBURst:FIND:START

SWEEP
COUNT

[SENSe:]SWEep:COUNT <num_value>

CAPTURE
AUTO OFF

: [SENSe<1|2>:]DDEMod:SEARch:MBURst:CAPTure ON | OFF

MULTI
ON OFF

: [SENSe<1|2>:]DDEMod:SEARch:MBURst:STATe ON | OFF

MEAS Key - not available

TRIG Key

TRIG	
FREE RUN	TRIGger[:SEquence]:SOURce IMMEDIATE
EXTERN	TRIGger[:SEquence]:SOURce EXTERNAL TRIGger[:SEquence]:LEVel[:EXTernal] 05V .. 3.5V [SENSe:]SWEep:EGATe:SOURce EXTERNAL
IF POWER	TRIGger[:SEquence]:LEVel:IFPower <numeric value>
TRIGGER OFFSET	TRIGger[:SEquence]:HOLDoff <num_value>
POLARITY POS/NEG	TRIGger[:SEquence]:SLOPe POSitive NEGative or [SENSe:]SWEep:EGATe:POLarity POSitive NEGative
MEAS ONLY ON PATT	: [SENSe<1 2>:]DDEMod:SEARCH:SYNC:MODE MEAS SYNC
MEAS ONLY ON BURST	: [SENSe<1 2>:]DDEMod:SEARCH:BURSt:MODE MEAS BURSt

TRACE Key

TRACE	
SELECT TRACE	--
CLEAR/ WRITE	:DISPlay[:WINDow<1 2>]:TRACe<1...3>:MODE WRITe
MAX HOLD	:DISPlay[:WINDow<1 2>]:TRACe<1...3>:MODE MAXHold or :[SENSe<1 2>:]AVERAge:MODE MAX
AVERAGE	:DISPlay[:WINDow<1 2>]:TRACe<1...3>:MODE AVERAge
VIEW	:DISPlay[:WINDow<1 2>]:TRACe<1...3>:MODE VIEW
BLANK	:DISPlay[:WINDow<1 2>]:TRACe<1...3>[:STATe] OFF
SWEEP COUNT	: [SENSe<1 2>:]SWEep:COUNT <num_value>
RMS	:DISPlay[:WINDow<1 2>]:TRACe<1...3>:MODE RMS
MIN HOLD	:DISPlay[:WINDow<1 2>]:TRACe<1...3>:MODE MINHold
AVG MODE LIN LOG	:CALCulate<1 2>:MATH:MODE LINear LOGarithmic

FILE EXPORT	:FORMat:DATA ASCii :MMEMory:STORe:TRACe <numeric_value>, <file_name>
FILE IMPORT	:FORMat:DATA ASCii :MMEMory:LOAD:TRACe <numeric_value>, <file_name>
DATA RAW (ASCII)	:FORMat:DEXPort:MODE RAW TRACe
HEADER ON OFF	:FORMat:DEXPort:HEADer ON OFF
DECIM SEP . /	:FORMat:DEXPort:DSEParator POINT COMMa

LINES Key

LINES	
SELECT LIMIT LINE	<p>Selection: CALCulate<1 2>:LIMit<1...8>:NAME <string>; CALCulate<1 2>:LIMit<1...8>:UPPer:STATe ON OFF CALCulate<1 2>:LIMit<1...8>:LOWer:STATe ON OFF</p> <p>Limit Check: CALCulate<1 2>:LIMit<1...8>:STATe ON OFF INITiate[:IMMediate]; WAI* CALCulate<1 2>:LIMit<1...8>:FAIL?</p> <p>Trace: CALCulate<1 2>:LIMit<1...8>:TRACe 1 2 3</p>
NEW LIMIT LINE	
NAME	<p>Name: CALCulate<1 2>:LIMit<1...8>:NAME <string>;</p> <p>Domain: CALCulate<1 2>:LIMit<1...8>:CONTRol:DOMain FREQuency TIME</p> <p>Scaling: CALCulate<1 2>:LIMit<1...8>:CONTRol:MODE RELative ABSolute CALCulate<1 2>:LIMit<1...8>:UPPer:MODE RELative ABSolute CALCulate<1 2>:LIMit<1...8>:LOWer:MODE RELative ABSolute</p> <p>Unit: CALCulate<1 2>:LIMit<1...8>:UNIT DBM DBPW WATT DBUV VOLT DBUA AMPere DB DBUV_MHZ DBUA_MHZ DEG RAD S HZ PCT</p> <p>Margin: CALCulate<1 2>:LIMit<1...8>:UPPer:MARGIn <num_value> CALCulate<1 2>:LIMit<1...8>:LOWer:MARGIn <num_value></p> <p>Threshold for relative y scaling: CALCulate<1 2>:LIMit<1...8>:UPPer:THReshold <num_value> CALCulate<1 2>:LIMit<1...8>:LOWer:THReshold <num_value></p> <p>Comment: CALCulate<1 2>:LIMit<1...8>:COMMeNt <string></p>
VALUES	CALCulate<1 2>:LIMit<1...8>:CONTRol[:DATA] <num_value>, <num_value>.. CALCulate<1 2>:LIMit<1...8>:UPPer[:DATA] <num_value>, <num_value>.. CALCulate<1 2>:LIMit<1...8>:LOWer[:DATA] <num_value>, <num_value>..
INSERT VALUE	No function in the IEC/IEEE bus operation.
DELETE VALUE	No function in the IEC/IEEE bus operation.

<div style="border: 1px solid black; padding: 2px; width: fit-content;">SHIFT X LIMIT LINE</div>	<p>CALCulate<1 2>:LIMit<1...8>:CONTRol:SHIFt <num_value></p>
<div style="border: 1px solid black; padding: 2px; width: fit-content;">SHIFT Y LIMIT LINE</div>	<p>CALCulate<1 2>:LIMit<1...8>:UPPer:SHIFt <num_value> CALCulate<1 2>:LIMit<1...8>:LOWer:SHIFt <num_value></p>
<div style="border: 1px solid black; padding: 2px; width: fit-content;">SAVE LIMIT LINE</div>	<p>Automatically executed in remote control</p>
<div style="border: 1px solid black; padding: 2px; width: fit-content;">EDIT LIMIT LINE</div>	<p>s. EDIT LIMIT LINE</p>
<div style="border: 1px solid black; padding: 2px; width: fit-content;">COPY LIMIT LINE</div>	<p>CALCulate<1 2>:LIMit<1...8>:COPY 1...8 <name></p>
<div style="border: 1px solid black; padding: 2px; width: fit-content;">DELETE LIMIT LINE</div>	<p>CALCulate<1 2>:LIMit<1...8>:DELeTe</p>
<div style="border: 1px solid black; padding: 2px; width: fit-content;">X OFFSET</div>	<p>CALCulate<1 2>:LIMit<1...8>:CONTRol:OFFset <num_value></p>
<div style="border: 1px solid black; padding: 2px; width: fit-content;">Y OFFSET</div>	<p>CALCulate<1 2>:LIMit<1...8>:UPPer:OFFset <num_value> CALCulate<1 2>:LIMit<1...8>:LOWer:OFFset <num_value></p>

DISP Key

DISP	
FULL SCREEN	DISPlay:FORmat SINGLE DISPlay[:WINDow<1 2>]:SElect
SPLIT SCREEN	DISPlay:FORmat SPLit
CONFIG DISPLAY	--
SCREEN TITLE	DISPlay[:WINDow<1 2>]:TEXT[:DATA] <string> DISPlay[:WINDow<1 2>]:TEXT:STATe ON OFF
TIME/DATE ON OFF	DISPlay[:WINDow<1 2>]:TIME ON OFF
LOGO ON/OFF	DISPlay:LOGO ON OFF
ANNOTATION ON/OFF	DISPlay:ANNotation:FREQuency ON OFF
DATAENTRY OPAQUE	No function in the IEC/IEEE bus operation.
DEFAULT COLORS 1	DISPlay:CMAp<1...13>:DEFault1
DEFAULT COLORS 2	DISPlay:CMAp<1...13>:DEFault2
DISPLAY PWR SAVE	DISPlay:PSAVe[:STATe] ON OFF DISPlay:PSAVe:HOLDoff <num_value>
SELECT OBJECT	--
BRIGHTNESS	DISPlay:CMAp:HSL <hue>,<sat>,<lum>
TINT	DISPlay:CMAp<1...13>:HSL <hue>,<sat>,<lum>
SATURATION	DISPlay:CMAp<1...13>:HSL <hue>,<sat>,<lum>
PREDEFINED COLORS	DISPlay:CMAp<1...13>:PDEFined BLACK BLUE BROWN GREen CYAN RED MAGenta YELLow WHITE DGRAY LGRAY LBLUe LGREen LCYan LRED MAGenta

FILE Key

FILE	
SAVE	MMEemory:STORe:STATe 1,<file_name>
RECALL	MMEemory:LOAD:STATe 1,<file_name>
EDIT COMMENT	MMEemory:COMMeNt <string>
ITEMS TO SAVE/RCL	
SELECT ITEMS	MMEemory:SElect[:ITEM]:HWSettings ON OFF MMEemory:SElect[:ITEM]:TRACe[:ACTive] ON OFF MMEemory:SElect[:ITEM]:LINES:ALL ON OFF MMEemory:SElect[:ITEM]:NONE
DEFAULT CONFIG	MMEemory:SElect[:ITEM]:DEfauLt
DISABLE ALL ITEMS	MMEemory:SElect[:ITEM]:NONE
ENABLE ALL ITEMS	MMEemory:SElect[:ITEM]:ALL
DATA SET LIST	--
STARTUP RECALL	MMEemory:LOAD:AUTO 1,<file_name>
FILE MANAGER	
EDIT PATH	MMEemory:MSIS <device> MMEemory:CDIRectory <directory_name>
MAKE DIRECTORY	MMEemory:MDIRectory <directory_name>
FORMAT DISK	MMEemory:INITialize <msus>
RENAME	MMEemory:MOVE <file_source>,<file_destination>
SORT MODE	No function in the IEC/IEEE bus operation.
COPY	MMEemory:COpy <file_source>,<file_destination>
DELETE	MMEemory:DElete <file_name> MMEemory:RDIRectory <directory_name>

CAL Key

CAL	
CAL TOTAL	CALibration[:ALL]?
CAL ABORT	CALibration:ABORT
CAL CORR ON OFF	CALibration:STATe ON OFF
CAL RESULTS	CALibration:RESults?

SETUP Key

REFERENCE INT/EXT	[SENSe:]ROSCillator:SOURce INTernal EXTernal
NOISE SCR ON OFF	DIAGnostic:SERvice:NSource ON OFF <num_value>
SIGNAL SOURCE	
YIG FILTER ON OFF	INPut<1 2>:FILTer:YIG[:STATe] ON OFF (R&S FSQ only)
RF PATH	INPut<1 2>:SElect RF This softkey is available only if the unit is equipped with Option R&S FSQ-B71 (Baseband Input).
BASEBAND ANALOG	INPut<1 2>:SElect AIQ This softkey is available only if the unit is equipped with Option R&S FSQ-B71 (Baseband Input).
IQ INPUT 50 1k	INPut<1 2>:IQ:IMPedance LOW HIGH This softkey is available only if the unit is equipped with Option R&S FSQ-B71 (Baseband Input).
BALANCED ON OFF	INPut<1 2>:IQ:BALanced ON OFF This softkey is available only if the unit is equipped with Option R&S FSQ-B71 (Baseband Input).
LOWPASS 36 MHZ	SENSe<1 2>:IQ:LPASS[:STATe] ON OFF This softkey is available only if the unit is equipped with Option R&S FSQ-B71 (Baseband Input).
DITHER ON OFF	SENSe<1 2>:IQ:DITher[:STATe] ON OFF This softkey is available only if the unit is equipped with Option R&S FSQ-B71 (Baseband Input).
PREAMP	INPut:GAIN:STATe ON OFF This softkey is available only if the unit is equipped with Option R&S FSx-B25 (Electronic Attenuator).
GENERAL SETUP	--
GPIB ADDRESS	SYSTem:COMMunicate:GPIB[:SELF]:ADDRESS 0...30
COM INTERFACE	SYSTem:COMMunicate:SERial[:RECeive:]BAUD <num_value> SYSTem:COMMunicate:SERial[:RECeive:]BITS 7 8 SYSTem:COMMunicate:SERial:RECeive:PARity[:TYPE] EVEN ODD NONE SYSTem:COMMunicate:SERial[:RECeive:]SBIts 1 2 SYSTem:COMMunicate:SERial:CONTRol:DTR IBFull OFF SYSTem:COMMunicate:SERial:CONTRol:RTS IBFull OFF SYSTem:COMMunicate:SERial[:RECeive:]PACE XON NONE
TIME+DATE	SYSTem:TIME 0...23, 0...59, 0...59 SYSTem:DATE <num>,<num>,<num>

CONFIGURE NETWORK	--
NETWORK LOGIN	--
OPTIONS	--
SOFT FRONT PANEL	--
SYSTEM INFO	--
HARDWARE INFO	DIAGnostic:SERvice:HWInfo?
STATISTICS	--
SYSTEM MESSAGES	SYSTem:ERRor? SYSTem:ERRor:LIST?
CLEAR ALL MESSAGES	SYSTem:ERRor?
SAVE CHANGES	--
SERVICE	--
INPUT RF	DIAGnostic:SERvice:INPut[:SElect] RF
INPUT CAL	DIAGnostic:SERvice:INPut[:SElect] CALibration DIAGnostic:SERvice:CSource[:POWer] <num_value>
SELFTEST	*TST?
SELFTEST RESULTS	DIAGnostic:SERvice:STEST:RESult?
REFERENCE FREQUENCY	[SENSE<1 2>:]ROSCillator[:INTernal]:TUNe 0...4095
CAL SIGNAL POWER	--
SAVE CHANGES	[SENSE<1 2>:]ROSCillator[:INTernal]:TUNe:SAVe
ENTER PASSWORD	SYSTem:PASSword[:CENable] <string>
CAL GEN 128 MHz	DIAGnostic:SERvice:INPut:PULSed OFF
CAL GEN COMB	DIAGnostic:SERvice:INPut:PULSed ON DIAGnostic:SERvice:INPut:PULSed:PRATe 128 MHz
SERVICE FUNCTION	DIAGnostic:SERvice:SFUNction <string>
FIRMWARE UPDATE	--
RESTORE FIRMWARE	--

HCOPY Key

HCOPY	
PRINT SCREEN	<p>HCOPY:ITEM:ALL HCOPY:IMMEDIATE</p> <p>If the printout is also to be stored in a file, enter the following command. MMEMORY:NAME <file_name></p>
PRINT TRACE	<p>HCOPY:ITEM:WINDOW<1 2>:TRACE:STATE ON OFF HCOPY:IMMEDIATE</p> <p>If the printout is also to be stored in a file, enter the following command. MMEMORY:NAME <file_name></p>
PRINT TABLE	<p>HCOPY:ITEM:WINDOW<1 2>:TABLE:STATE ON OFF HCOPY:IMMEDIATE</p> <p>If the printout is also to be stored in a file, enter the following command. MMEMORY:NAME <file_name></p>
HARDCOPY ABORT	HCOPY:ABORT
DEVICE1	<p>SYSTEM:COMMUNICATE:PRINTER:ENUMERATE:FIRST? SYSTEM:COMMUNICATE:PRINTER:ENUMERATE:NEXT? SYSTEM:COMMUNICATE:PRINTER:SELECT <string> HCOPY:DESTINATION <string> HCOPY:DEVICE:LANGUAGE GDI WMF EWMF BMP HCOPY:PAGE:ORIENTATION<1 2> LANDSCAPE PORTRAIT</p>
DEVICE2	<p>SYSTEM:COMMUNICATE:PRINTER:ENUMERATE:FIRST? SYSTEM:COMMUNICATE:PRINTER:ENUMERATE:NEXT? SYSTEM:COMMUNICATE:PRINTER:SELECT "string" HCOPY:DESTINATION2 <string> HCOPY:DEVICE:LANGUAGE GDI WMF EWMF BMP HCOPY:PAGE:ORIENTATION<1 2> LANDSCAPE PORTRAIT</p>
COLOR	<p>HCOPY:DEVICE:COLOR ON OFF HCOPY:CMAP:DEFAULT1</p>
COMMENT SCREEN A/B	HCOPY:ITEM:WINDOW<1 2>:TEXT <string>
INSTALL PRINTER	

Hotkey Bar

SPECTRUM	<p>INSTRUMENT[:SELECT] SANALYZER INSTRUMENT:NSELECT 1</p>
NETWORK	<p>This softkey is available only if the unit is equipped with Option R&S FSP-B9 (Tracking Generator) or Option R&S FSP-B10 (Ext. Generator Control); see description of basic unit. --</p>
SCREEN A/B	<p>FULL SCREEN: Selection of active window: DISPLAY[:WINDOW<1 2>]:SELECT The window for which the setting is to be valid is selected by the numeric suffix in the command, e.g. SENSE<1 2></p> <p>SPLIT SCREEN: Both measurement windows are active The window for which the setting is to be valid is selected by the numeric suffix in the command, e.g. SENSE<1 2>.</p>

Status-QUESTIONable:SYNC Register

This register contains information about the synchronization or burst search, provided that the unit is equipped with Option R&S FSQ-K70/FSMR-B73/FSU-B73 (Vector Signal Analysis). The register can be queried with the commands "STATUS:QUESTIONable:SYNC:CONDition?" or "STATUS:QUESTIONable:SYNC[:EVENT]?"

Table 10 Meaning of bits in the STATUS: QUESTIONable:SYNC register

Bit No.	Meaning
0	BURSt not found This bit is set if a burst could not be clearly found.
1	SYNC not found This bit is set if the sync sequence of the midamble could not be found.
6	DEMod failed This bit is set if the signal at the R&S FSQ/FSMR/FSU input is invalid.
7	End of buffer reached This bit is set in multi mode when the end of capture buffer is reached and insufficient data are available.
15	This bit is always 0.

STATUS-QUESTIONable:POWER Register

This register comprises all information about possible overloads of the unit.

It can be queried with commands STATUS:QUESTIONable:POWER:CONDition? and "STATUS:QUESTIONable:POWER[:EVENT]?". In operating mode Vector Signal Analysis only bits 0 to 2 are used.

Table 11 Meaning of bits in the STATUS: QUESTIONable:POWER register

Bit-Nr	Bedeutung
0	OVERload his bit is set if the RF input is overloaded. 'OVLD' will then be displayed
1	UNDERload This bit is set if the RF input is underloaded. 'UNLD' will then be displayed.
2	IF_OVERload This bit is set if the IF path is overloaded. 'IFOVL' will then be displayed.
3-7	not used
15	This bit is always 0.

7 Checking the Rated Specifications

Switch off R&S FSQ/FSMR/FSU prior to removing or inserting modules.

Prior to switching the unit on, check position of voltage selector (230 V).

Measure the rated specifications only after a warm-up time of at least 30 minutes and after autocalibration of the R&S FSQ/FSMR/FSU and the R&S SMIQ. Only then can it be ensured that the specifications are complied with.

Unless otherwise specified, all settings are made based on the PRESET setting.

The settings for the measurements to be performed on the R&S FSQ/FSMR/FSU are subject to the following:

- [<KEY>] Press a key on the front panel, e.g. [SPAN].
- [<SOFTKEY>] Press a softkey, e.g. [MARKER -> PEAK].
- Only[<nn unit>] Enter a value + terminate the entry with the unit, e.g. [12 kHz].
- {<nn>} Enter values provided in one of the following tables.

Successive entries are separated by [:], e.g. [**SPAN**:15 kHz].

The values in the following sections cannot be guaranteed.

Required Test Equipment and Accessories

Table 12 Required Measuring Equipment and Accessories

Item	Type of unit	Recommended characteristics	Recommended unit	R&S Order No.	Application
1	Signal generator	Vector signal generator for WCDMA-signals	SMIQ with options: SMIQB45 SMIQB20 SMIQB11	1125.5555.03 1104.8232.02 1125.5190.02 1085.4502.04	

Test Sequence

The performance test only refers to the results of the vector signal analysis.

Default setup on the [**PRESET**]
R&S SMIQ: [**LEVEL :** -30 dBm]
[**FREQ:** 2.0 GHz]
DIGITAL MODULATION
STANDARD WCDMA QPSK
STATE: ON

Default setup on the **[PRESET]**
 R&S FSQ/FSMR/FSU: **[CENTER: 2.0 GHz]**
[REF: -20 dBm]
[3GPP_WCDMA_FWD]
[TRIG FREE RUN]
[DISPLAY EVM, MODULATION ERRORS]

The measurement result displayed on the R&S FSQ/FSMR/FSU should have the following values:

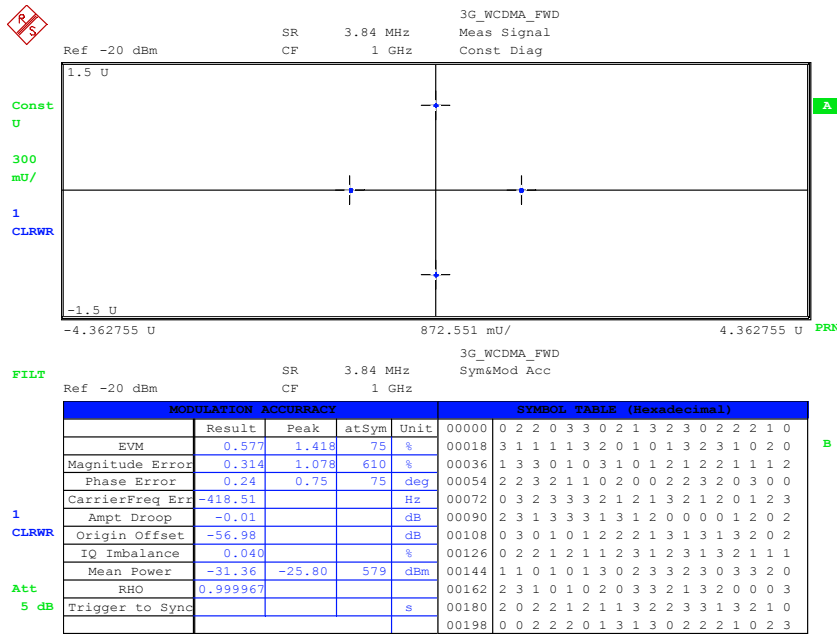

Date: 27.JAN.2003 11:04:44

The EVM should not exceed 5% (RMS).

8 Utilities / External Programs

Mapping Editor (MAPWIZ)

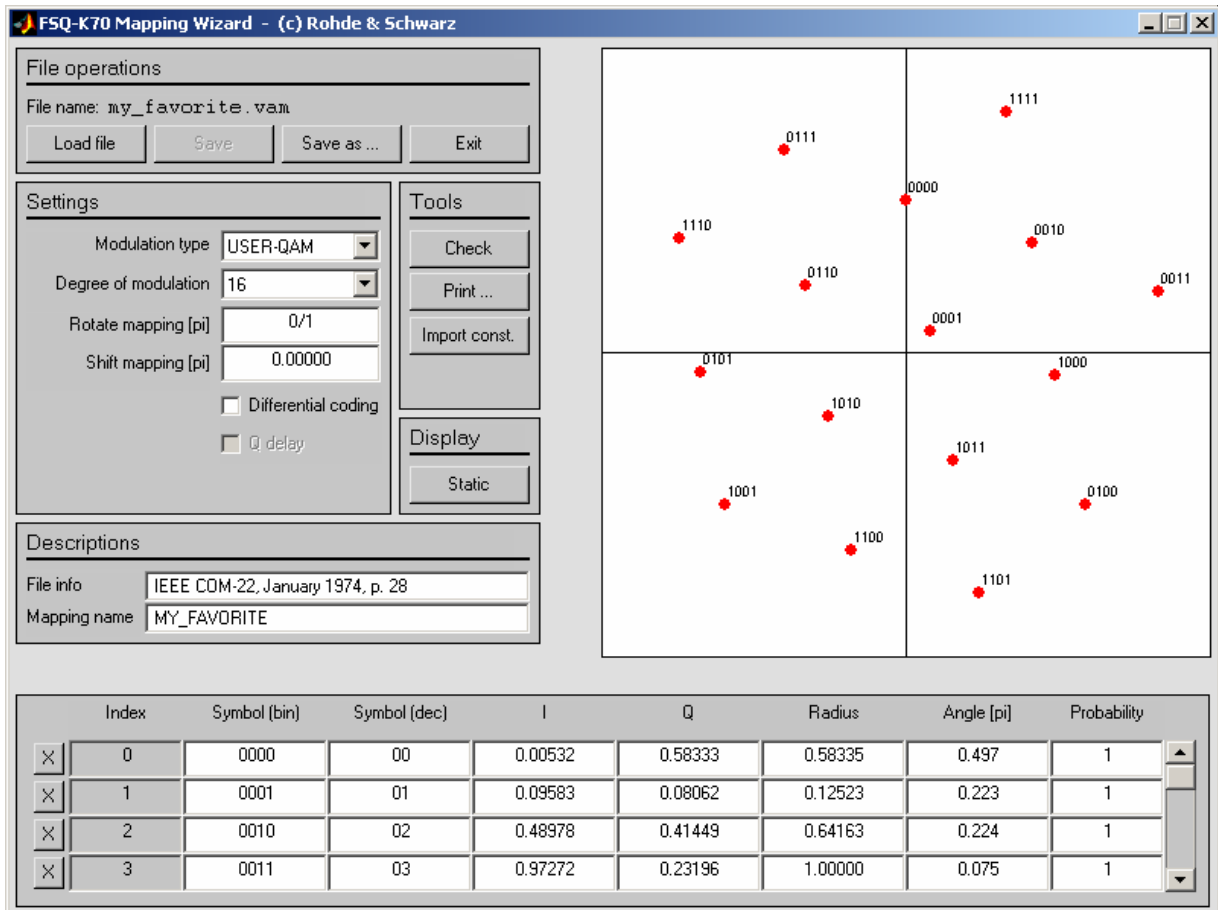

Fig. 256 MAPWIZ -Mapping editor for the R&S FSQ-K70/FSMR-B73/FSU-B73

An external program (MAPWIZ) is offered to create individual constellations (including symbol mappings) or to modify available mapping files. This program generates mapping files (*.vam) which are transmitted to the analyzer via the IMPORT function and by loading the data from a floppy disk.

The program can be downloaded together with a detailed description as precompiled MATLABb® file (MATLAB pcode) on the Internet, page <http://www.rohde-schwarz.com> (search term "MAPWIZ").

Filter Tool (FILTWIZ)

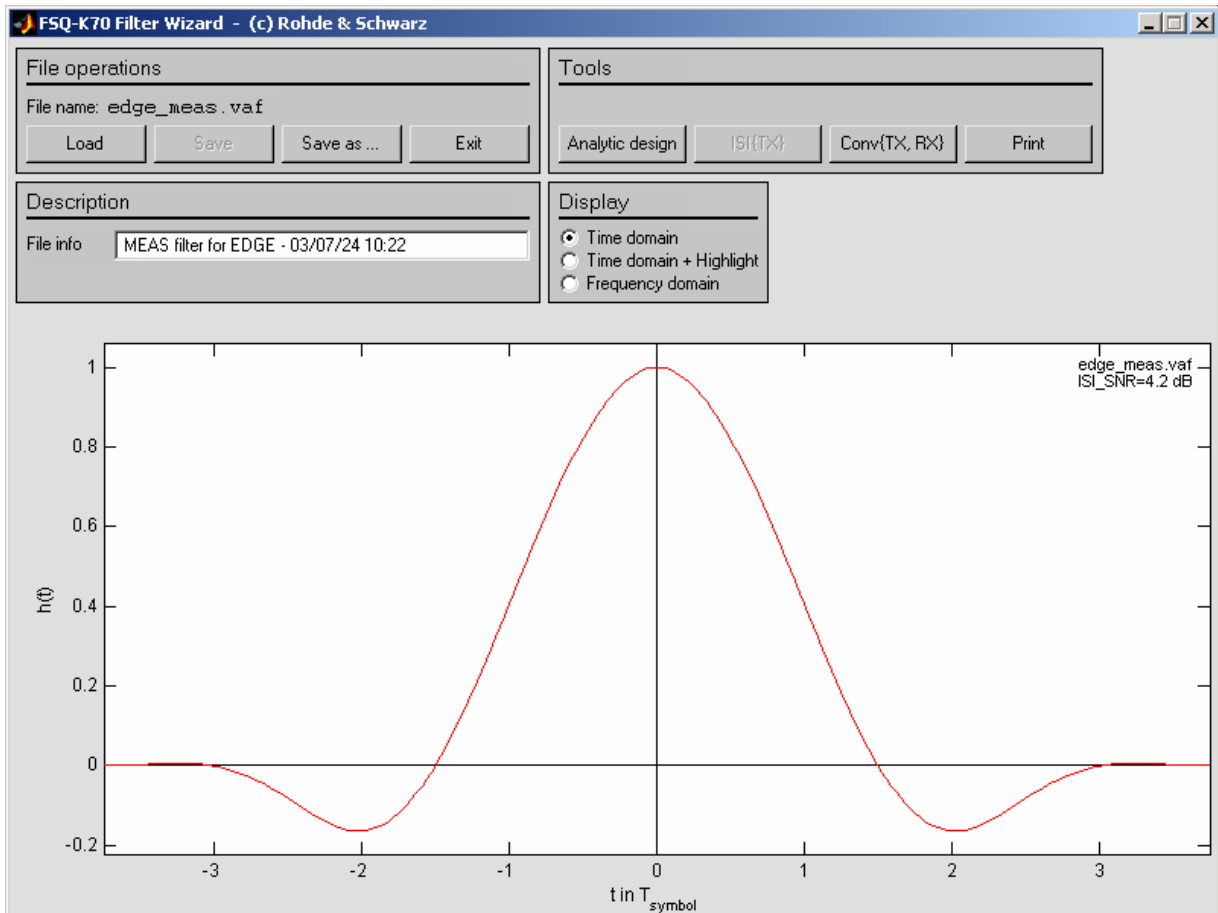

Fig. 257 FILTWIZ - filter tool for the R&S FSQ-K70/FSMR-B73/FSU-B73

An external program (FILTWIZ) is offered to convert user-defined filters. This program generates filter files (*.vaf) which are transmitted to the analyzer via the IMPORT function and by loading the data from a floppy disk.

The program can be downloaded together with a detailed description as precompiled MATLAB® file (MATLAB pcode) on the Internet, page <http://www.rohde-schwarz.com> (search term "FILTWIZ").

9 Glossary and Formulae

Trace-based Evaluations

Test parameter	Formula
Magnitude	$MAG_{MEAS}(t) = MEAS(t) ;$ $MAG_{REF}(t) = REF(t) ;$
Phase	$PHASE_{MEAS}(t) = \arg(MEAS(t));$ $PHASE_{REF}(t) = \arg(REF(t));$
Magnitude error	$MAG_ERR(t) = MEAS(t) - REF(t) ;$
Phase error	$PHASE_ERR(t) = \arg(MEAS(t) \cdot REF^*(t));$
Error Vector = EV	$EV(t) = MEAS(t) - REF(t);$
Error Vector Magnitude = EVM	$EVM(t) = \frac{ EV(t) }{C};$ <p>In case of Offset-QPSK please observe the influence of the softkey "Offset EVM ON/OFF" on nominator and denominator.</p>
Frequency (MSK)	$FREQ_{MEAS}(t) = \frac{d}{dt}(\text{unwrap}(\arg(MEAS(t))));$ $FREQ_{REF}(t) = \frac{d}{dt}(\text{unwrap}(\arg(REF(t))));$
Frequency error (MSK,FSK)	$FREQ_ERR(t) = FREQ_{MEAS}(t) - FREQ_{REF}(t);$
	$t = n \cdot Ta; \text{ where } Ta = \text{sampling period}$

Summary - Evaluations

RHO (correlation coefficient)	$\rho = \frac{\left \sum_n REF^*(k) \cdot MEAS(k) \right ^2}{\sum_n REF(k) ^2 \cdot \sum_n MEAS(k) ^2} = \frac{KKF(MEAS, REF)}{AKF(REF) \cdot AKF(MEAS)}$
Normalization constant C (not VSB)	$C = \sqrt{\frac{1}{K} \sum_K REF(k) ^2} = \text{sqrt}(\text{mean power of the symbol decision instants})$ <p>But if the softkey "EVM CALC" is set to "MAX SYMBOL POWER", the factor C is not calculated as given above, but set to the constant ideal value of the maximum symbol magnitude.</p> <p>In case of Offset-QPSK please observe the additional influence of the softkey "OFFSET EVM ON/OFF" on the determination of the symbol instants in the I- and Q-part of the REF signal.</p>
Normalization constant C (VSB only)	$C = \sqrt{\frac{1}{K} \sum_K \text{Re}\{REF(k)\} ^2} = \text{sqrt}(\text{mean power of the symbol decision instants}).$ <p>But if the softkey "EVM CALC" is set to "MAX SYMBOL POWER", the factor C is not calculated as given above, but set to the constant ideal value of the maximum symbol magnitude.</p>
RMS_Magnitude _Error	$RMS_MagErr = \sqrt{\frac{1}{K} \sum_K MAG_ERR(k) ^2}$
RMS_EVM (not VSB)	$RMS_EVM = \sqrt{\frac{1}{K} \sum_K EVM(k)^2}$ <p>In case of Offset-QPSK please observe the influence of the softkey "Offset EVM" on the EVM trace.</p>
RMS_EVM (VSB only)	$RMS_EVM = \sqrt{\frac{1}{K} \sum_K \text{Re}\{EVM(k)\}^2}$
Origin_Offset (logarithmic measure for IQ_Offset)	$OriginOffset = 10 \log_{10} \left(\frac{ IQ_Offset ^2}{C^2} \right)$ <p>Note: For the normalization of the "Origin Offset" the denominator C does not depend on the softkey "EVM CALC" and "OFFSET EVM". The calculation assumes that they are set to "MEAN SIGNAL POWER" respectively "OFFSET EVM OFF".</p>
Amplitude Droop (Measure for exponential level modifications within the measurement range)	$MEAS\left(\frac{t}{T_s}\right) = REF\left(\frac{t}{T_s}\right) \cdot e^{-\alpha \frac{t}{T_s}}$ $AMPT_DROOP = 20 \log_{10}(e^{-\alpha})$ <p>α is the level modification/symbol (in [Neper])</p>

	AMPT_DROOP is the equivalent value in [dB]
Mean Power (Mean power of the receive signal)	$MEAN_POWER = 10 \log_{10} \left(\frac{1}{M} \sum_m U_m^2 \right); [dBm]$ <p>Logarithmized value of the mean power of all samples. If a measurement filter is activated, it also affects the calculation of the mean power.</p>
SNR (MER) (Signal-to-noise ratio)	$SNR = 10 \log_{10} \left(\frac{\text{signal power}}{\text{noise power}} \right) = \frac{\frac{1}{N} \sum_{n=0}^{N-1} REF(n \cdot T_{symbol}) ^2}{\frac{1}{N} \sum_{n=0}^{N-1} MEAS(n \cdot T_{symbol}) - REF(n \cdot T_{symbol}) ^2}$ <p>The SNR (signal-to-noise ratio) is the quotient of the signal power of the ideal signal (REF signal) and the noise power. The signal power is calculated as the mean power of the ideal signal (REF signal) at symbol decision points. The noise power is calculated as the mean power of the error signal, i.e. the difference of the measured signal and the corresponding ideal signal (MEAS-REF signal), at symbol decision points. For VSB, only the power of the real part is considered.</p> <p>The definition of the SNR has been changed with firmware version 4.20. In older versions the SNR was calculated in the same way as the EVM and did depend on the softkey "EVM CALC".</p> <p>The parameter "EVM calc" does always influence the calculation of EVM.</p>
FSK method:	$\text{Min} \left\{ MEAS(t) - (a \cdot REF(t) + b \cdot t + c) ^2 \right\}$ $FSK_Meas_Dev = reference_deviation \cdot a [Hz]$ $Carrier_Freq_Drift = b [Hz]$ $Carrier_Freq_Err = c [Hz]$ $FSK_Dev_Error = MEAS(t) - (a \cdot REF(t) + b \cdot t + c) [Hz]$ $RMS_FSK_DEV_Error = \sqrt{\frac{1}{M} \sum_m FSK_Dev_Error_m^2} [Hz]$
	.k = symbol decision instant Ts = symbol duration

Statistical Evaluations

MEAN (Average, AVG)	Voltage, %, ° (linear)	$MEAN_U = \frac{\sum U_m}{M};$
	Power (logarithmic)	$MEAN_IP = 20 * \log_{10} \left(\frac{1}{M} \sum_{10}^{\frac{IP_m}{20}} \right);$
STD_DEV	Linear	$STDDEV_R = \sqrt{\frac{1}{M} \sum (R_m - MEAN(R_m))^2};$
95 pctl	95 pctl	$x_{.95} = \{x w_n(x) = 0.95\};$
Total Peak (Extreme value of peak values)	Total Peak (Extreme value of peak values)	$TOTAL_Pk = \begin{cases} \max\{Pk1 & Pk2 & \dots & Pkn\} & \text{if max} \geq -\text{min} \\ \min\{Pk1 & Pk2 & \dots & Pkn\} & \text{if max} < -\text{min} \end{cases};$

Trace Averaging and Marker Functions

Linear values	Voltage, % °	$RMS_U_m = \sqrt{\frac{M-1}{M} RMS_U_{m-1}^2 + \frac{1}{M} U_m^2};$
	Power W	$RMS_P_m = \frac{M-1}{M} RMS_P_{m-1} + \frac{1}{M} P_m;$
Logarithmic values	Voltage dBV, origin offset	$RMS_IU_m = 20 * \log \left(\frac{M-1}{M} 10^{\frac{RMS_IU_{m-1}}{20}} + \frac{1}{M} 10^{\frac{IU_m}{20}} \right);$
	Power dBm	$RMS_IP_m = 10 * \log \left(\frac{M-1}{M} 10^{\frac{RMS_IP_{m-1}}{10}} + \frac{1}{M} 10^{\frac{IP_m}{10}} \right);$

Averaging RMS Quantities

RMS	Voltage, %, ° (linear)	$RMS_U = \sqrt{\frac{1}{M} \sum U_m^2}$
RMS	Power (W, mW ...) linear	$RMS_P = \frac{1}{M} \sum P_m$
RMS	Power (logarithmic)	$RMS_IP = 10 * \log_{10} \left(\frac{1}{M} \sum_{10}^{\frac{IP_m}{10}} \right)$

Analytically Calculated Filters

The following filters are calculated during runtime of the unit and as a function of operating parameter ALFA or BT.

Raised cosine filter	RC Setting parameter = ALFA	$H(f) = \begin{cases} T & , \text{für } 0 \leq f \leq \frac{1-\alpha}{2T} \\ \frac{T}{2} \left[1 + \cos\left(\frac{\pi T}{\alpha} \left(f - \frac{1-\alpha}{2T}\right)\right) \right] & , \text{für } \frac{1-\alpha}{2T} \leq f \leq \frac{1+\alpha}{2T} \\ 0 & , \text{für } \frac{1+\alpha}{2T} \leq f \end{cases}$ $h(t) = \text{sinc}\left(\frac{\pi t}{T}\right) \frac{\cos\left(\frac{\pi \alpha t}{T}\right)}{1 - 4\left(\frac{\alpha t}{T}\right)^2}; \text{ where } \text{sinc}(x) = \frac{\sin(x)}{x};$ <p>{T} corresponds to symbol period.</p>
Root raised cosine filter	RRC Setting parameter = ALFA	$H(f) = \begin{cases} T & , \text{for } 0 \leq f \leq \frac{1-\alpha}{2T} \\ T \sqrt{\frac{1}{2} \left[1 - \sin\left(\frac{\pi T}{\alpha} \left(f - \frac{1-\alpha}{2T}\right)\right) \right]} & , \text{for } \frac{1-\alpha}{2T} \leq f \leq \frac{1+\alpha}{2T} \\ 0 & , \text{for } \frac{1+\alpha}{2T} \leq f \end{cases}$ $h(t) = \frac{1}{c} \frac{\sin\left(\pi \cdot (1-\alpha) \cdot \frac{t}{T}\right) + 4\alpha \frac{t}{T} \cdot \cos\left(\pi \cdot (1+\alpha) \cdot \frac{t}{T}\right)}{\pi \cdot \frac{t}{T} \cdot \left(1 - \left(4\alpha \frac{t}{T}\right)^2\right)};$ <p>where $c = 1 - \alpha + \frac{4\alpha}{\pi}$</p>
Gaussian filter ETSI TS 100 959 (V8.3.0)	GAUSS Setting parameter = BT	$h(t) = \frac{\exp\left(\frac{-t^2}{2s^2 T^2}\right)}{\sqrt{(2\pi) \cdot s T}}; \text{ where } s = \frac{\sqrt{\ln 2}}{2\pi B T};$ $H(f) = \exp\left(\frac{\ln 2}{2B^2} f^2\right);$

H(f) defines the frequency response, h(t) the coefficients in the time domain. The limit lines have to be checked against the denominator zeros when the filter coefficient is determined.

The filter coefficients in the time domain may be normalized in the analyzer, if required, so that the following equation applies: $h(t = 0) = 1$;

Standard-Specific Filters

<p>EDGE-TX filter ETSI TS 300 959 (V8.1.2)</p>	<p>EDGE TX</p>	$c_0(t) = \begin{cases} \prod_{i=0}^3 S(t+iT) & \text{for } 0 \leq t \leq 5T \\ 0 & \text{else} \end{cases};$ $S(t) = \begin{cases} \sin(\pi \int_0^t g(t') dt') & \text{for } 0 \leq t \leq 4T \\ \sin\left(\frac{\pi}{2} - \pi \int_0^{t-4T} g(t') dt'\right) & \text{for } 4T < t \leq 8T \\ 0 & \text{else} \end{cases};$ $g(t) = \frac{1}{2T} \left(Q\left(2\pi * 0.3 \frac{t-5T/2}{T\sqrt{\ln(2)}}\right) - Q\left(2\pi * 0.3 \frac{t-3T/2}{T\sqrt{\ln(2)}}\right) \right);$ $Q(t) = \frac{1}{\sqrt{2\pi}} \int_t^\infty e^{-\frac{\tau^2}{2}} d\tau;$ <p>$c_0(t)$ is the impulse response of the EDGE transmit filter.</p>
<p>EDGE measurement filter GSM 05.06 (V8.2.0)</p>	<p>EDGE MEAS</p>	<p>RC filter, ALFA = 0.25, single-side-band 6 dB bandwidth = 90 kHz Windowing by multiplying the impulse response according to the following equation:</p> $w(t) = \begin{cases} 1, & 0 \leq t \leq 1.5T \\ 0.5(1 + \cos[\pi(t - 1.5T)/2.25T]), & 1.5T \leq t \leq 3.75T \\ 0, & t \geq 3.75T \end{cases}$ <p>(T = symbol interval)</p>
<p>CDMA-TX filter</p>	<p>Cdma_one_TX</p>	

Abbreviations Used

Abbreviation	Meaning	See section
VSA	Vector Signal Analysis Measurement at complex modulated RF carriers.	
TX filter	Transmitter Filter Digital impulse shaping filter in signal processing unit of transmitter.	System-Theoretical Modulation and Demodulation Filters
ISI-free demodulation	Demodulation structure in which the signal is no longer influenced by adjacent symbols at the decision instants after signal-adapted filtering.	System-Theoretical Modulation and Demodulation Filters
ISI filter	InterSymbol Interference Filter Baseband filter in analyzer used for signal-adapted filtering.	System-Theoretical Modulation and Demodulation Filters
MEAS filter	Measurement Filter Weighting filter for the measurement.	System-Theoretical Modulation and Demodulation Filters
PSK	Phase Shift Keying Modulation mode during which the information lies within the phase or within the phase transitions.	Phase Shift Keying (PSK)
FSK	Frequency Shift Keying Modulation mode during which the information is encrypted in the frequency.	Frequency Shift Keying (FSK)
MSK	Minimum Shift Keying Modulation mode.	Minimum Shift Keying (MSK)
QAM	Quadrature Amplitude Modulation Modulation mode during which the information is encrypted both in the amplitude and phase.	Quadrature Amplitude Modulation (QAM)
VSF	Vestigial Sideband Modulation Modulation mode during which one sideband is completely suppressed.	Vestigial Sideband Modulation (VSF)
NDA Demodulator	Non Data Aided Demodulator Demodulation without any knowledge of the sent data contents.	Demodulation and Algorithms
RMS	Root Mean Square	Averaging RMS Quantities
Average (Mean)	Linear average value	Trace Averaging and Marker Functions

10 Index

+

+/-PEAK/2 250

A

Activating the option 19
 Analog RBW prefilter 37
 Averaging 253

B

Block diagram 35
 BURST NOT FOUND 98
 Burst search 70, 127

C

Checking the rated specifications 353
 Command
 description 258

D

Demodulation bandwidth 39
 Demodulator 1 72
 Differential PSK (DPSK) 52

E

Enabling the option 17
 END OF BUFFER 98
 Error display 177
 Error model 83
 Exiting the option 19

F

Filter models 43
 Frequency shift keying (FSK) 56

H

Hotkey
 EXIT VSA 19
 HOME VSA 19, 106
 PRESET VSA 105
 SETTINGS 105
 VSA 19, 23, 293

I

I/Q bandwidth 38
 IF filter 37
 ISI = intersymbol interference 40
 ISI filter 41

K

Key
 AMPT 233
 BW 235
 CAL 228
 DISP 244
 FILE 245
 FREQUENCY 232
 HCOPI 231

PRESET 228
 SETUP 229
 SWEEP 236
 TRACE 239
 TRIGGER 238
 Keyword for enabling 17

L

Level threshold 128
 Limit
 evaluation range 252

M

Mapping 48
 Matched filter 40
 Matching 76
 Maximum peak value 252
 Maximum value 250
 MEAS filter 41
 Measurement bandwidth 39
 Measurement Result Display 162
 Measurement window 97
 Minimum shift keying (MSK) 57
 Modulation error (FSK) 92

N

NO VALID SIGNAL 98

O

Offset QPSK 54

P

Pattern 131
 PATTERN NOT FOUND 98
 Pattern search 78
 Patterns 125
 Performance test 353
 Phase & frequency recovery 72
 Phase ambiguity of demodulator 74
 Phase offset PSK 50
 Phase shift keying (PSK) 48
 Prefilter 37
 PSK mixed forms 53

R

Rated specifications 353
 RBW filter 37
 Receive filter 41
 Reference filter 41
 Result & error calculation 80
 Result Display 162
 RMS value 251
 RRC filter 40

S

Softkey
 +/-PEAK/2 250
 ADD PAT TO STD 134, 315
 ADJUST REF LVL 220, 307
 ALFA/BT 146, 302
 AM & PM CONVERSION 180, 261

AMPERE	288	FIT OFFSET	216
AVERAGE ON/OFF	253, 278, 281, 283, 284	FIT PATTERN	216, 287
BURST & PATTERN	127	FIT TRACE	216
BURST SRCH ON/OFF	127, 311	FIT TRIGGER	216, 287
CANCEL	116, 137	FORCE WB PATH	148, 320
CAPTURE AUTO/OFF	217, 311	FREQ ERROR (RELATIVE)	261
CAPTURE BUFFER	194	FREQ RESP	210
CHAN RESP	211	FREQUENCY	165, 179, 196, 261
COMP PT	248	FSK DEV	146, 261
DATA RAW	240, 292	GENERIC LIST	113
dBm	288	GROUP DELAY	208
dBmV	288	HEADER ON/OFF	240, 292
dBpW	288	HIGHLIGHT	160
dB μ A	288	HYSTERESIS MAN.	129, 309
dB μ V	288	IMPORT	222
DECIM SEP	240, 291	INSERT	136
DELETE	137	INSERT STANDARD	115
DELETE GENERIC STD	114	INSTALL OPTION	17
DELETE PATTERN	134, 314	IQ ERROR	183, 260
DELETE STANDARD	113, 317	IQ VECT / CONST	168, 261
DELETE USER SET	145	LIMIT ON/OFF	252
DEMOD @ ZOOM START	217, 312	MAG CAP BUFFER	195, 201, 260
DEMOD NEXT RIGHT	217, 312	MAGNITUDE	143, 144, 163, 204, 261
DEMOD RESTART	217, 312	MAGNITUDE ERROR	177, 261
DEMOD SETTINGS	147	MAPPINGS	223, 226, 301, 304
DIGITAL STANDARDS	112	MARKER 1 to 4	285
DISPLAY UNIT	234	MAX PEAK	250
EDIT	137	MAX HOLD ON/OFF	252, 279, 282, 283, 285
EDIT GENERIC	114	MEAN	251, 282
EDIT PATTERN	135, 313, 315, 316	MEAS ONLY ON BURST	131, 310
EQUALIZER	204	MEAS ONLY ON PATT	132, 315
EQUALIZER DELETE	300	MEAS RESULT	155, 260
EQUALIZER FREEZE	143, 299	MEAS SIGNAL	162, 260
EQUALIZER LENGTH	144, 300	MKR ->	247
EQUALIZER LOAD	144, 300	MKR FCT	247
EQUALIZER ON/OFF	299	MODULATION & MAPPING	140, 303, 305, 307, 308, 319, 320
EQUALIZER RESET	143, 300	MODULATION FILTER	142, 303
EQUALIZER SAVE	300	MODULATION SETTINGS	139
EQUALIZER SAVE	144	MULTI ON/OFF	217, 313
EQUALIZER SETTINGS	143	NEW GENERIC	114, 115
EQUALIZER STEP	144, 299	NEW PATTERN	135
EQUALIZER TRAIN	143, 299	NEW USER SET	145
EQUALIZERS	223, 227, 301, 303	NORMALIZE ON/OFF	149, 305
ERROR SIGNAL	177, 260	NUMBER OF SWEEPS	253
ERROR SPECTRUM	184	OFFSET EVM ON/OFF	159, 299
ERROR SPECTRUM / EVM	188	OPTIONS	17
ERROR SPECTRUM / FREQ ERROR	187	PAT POS	216, 319
ERROR SPECTRUM / MAGNITUDE ERROR	185	PAT SRCH ON/OFF	131, 316
ERROR SPECTRUM / PHASE ERROR	186	PATH	224, 227
ERROR SPECTRUM / REAL/IMAG	189	PATTERN	301, 302, 304
ERROR STATISTIC	189, 286	PATTERN LIST	133, 313
ERROR STATISTIC / EVM	193	PATTERN SELECT	131, 316
ERROR STATISTIC / FREQ ERROR	192	PATTERN SETTINGS	133, 314
ERROR STATISTIC / MAGNITUDE ERROR	190	PATTERNS	223, 227
ERROR STATISTIC / PHASE ERROR	191	PEAK	250, 277, 278
EVAL LINES	150, 263	-PEAK	250
EVM	182	PHASE	164, 205, 261
EVM CALC	160, 298	PHASE ERROR	178, 261
EXPAND PAT LIST	134	PHASE RESPONSE	209
EXPERT SETTINGS	130, 309, 310, 311	PndB OUT	266
EXPORT	225	POINTS/SYM	146, 149, 305
EYE I/Q	167, 261	POWER ON/OFF	277, 281, 282, 284
FACTORY DEFAULTS	221, 302	RANGE	218
FILE EXPORT	291	REAL/IMAG	166, 180, 197, 207, 261
FILE EXPORT	240	RECORD LEN	147, 308
FILE EXPORT	295	RECORD LEN (AUTO)	147, 309
FILE IMPORT	242, 294	RECORD LEN (x sec)	148, 309
FILTERS	223, 226, 304	RECORD LEN (x SYM)	148, 309
FIT ALIGN	216, 287	REF SIGNAL	162, 260
FIT ALIGN CENTER	216, 287	REFDEVCOMP ON/OFF	160, 262
FIT ALIGN LEFT	216, 287	REMOVE ALL FROM STD	134, 316
FIT ALIGN RIGHT	216, 287	REMOVE PAT FROM STD	134, 316
FIT BURST	216, 287		

REMOVE STANDARD.....	115
RESULT LEN.....	148, 319
RESULT RAW/FILT.....	156, 302
RMS.....	251, 281
SAVE.....	114, 137
SAVE AS STANDARD.....	113, 317, 318, 319
SAVE USER SET.....	145
SET SYMB #.....	216, 290
SHOW ALL STANDARDS.....	115
SHRINK PAT LIST.....	134
SIDEBAND NORM/INV.....	149, 309
SIGNAL SOURCE.....	230
SIGNAL STATISTIC.....	173, 286
SIGNAL STATISTIC / FREQUENCY.....	173, 176
SIGNAL STATISTIC / MAGNITUDE.....	174
SIGNAL STATISTIC / PHASE.....	175
SPECTRUM.....	169, 197, 259
SPECTRUM / FREQUENCY.....	199
SPECTRUM / MAG CAP BUFFER.....	198
SPECTRUM / MAGNITUDE.....	170
SPECTRUM / PHASE.....	171
SPECTRUM / REAL/IMAG.....	200
SPECTRUM STATISTIC / FREQUENCY.....	172
STAAISTIC / MAG CAP BUFFER.....	202
STANDARD DEFAULTS.....	113, 318
STANDARD DEVIATION.....	251, 284
STANDARD LIST.....	113, 306
STANDARDS.....	222, 225, 301, 304
START LIMIT.....	252
STATISTIC.....	201
STATISTIC / REAL/IMAG.....	203
STATISTICS / MAG CAP BUFFER.....	201
STD PAT LIST.....	133
STOP LIMIT.....	252
SUM MKR ON/OFF.....	249
SUMMARY MARKER.....	276
SYM RATE.....	139, 316
SYMBOLS & MOD ACC.....	157, 260, 268, 290
THRESHOLD.....	128
THRESHOLD ABSOLUTE.....	129, 311
THRESHOLD AUTO.....	128, 311
THRESHOLD RELATIVE.....	129, 311
TIME DOM POWER.....	277, 281, 282, 284
UNIT.....	288
VIEW OFFSET.....	216
VOLT.....	288
WATT.....	288
X UNIT SYMBOL.....	288
X UNIT TIME.....	288
X-AXIS /DIV.....	218, 289
X-AXIS LIN / LOG.....	218
X-AXIS QUANTIZE.....	218, 286
X-AXIS REF POS.....	218
X-AXIS REF VALUE.....	218, 289
Y-AXIS /DIV.....	218
Y-AXIS REF POS.....	218
Y-AXIS REF VALUE.....	218
ZOOM.....	194, 217
ZOOM LENGTH.....	217, 312
ZOOM START.....	217, 312
Standard	
Introduction.....	107
User-defined.....	113
Standard deviation.....	251
STATUS QUEStionable register	
POWER register.....	352
Status register	
STATus QUEStionable POWER.....	352
STATus-QUEStionable-SYNC.....	352
Switching on the option.....	19
Symbol mapping.....	48
Symbol pattern.....	125
Sync pattern.....	117, 125, 131
T	
Table PATTERN SETTINGS.....	135, 313, 315, 316
Timing Recovery.....	72
Transmit filter.....	41
TX filter.....	41
U	
USER-QAM.....	64, 355
V	
Vestigial Sideband Modulation.....	65
VSB.....	65